

Model 3070

COMPRESSOR/LIMITER

Owner's Manual



FOSTEX[®]

TABLE OF CONTENTS

1. LOCATION OF CONTROLS (Front panel)	2
2. LOCATION OF CONNECTIONS (Rear panel)	5
3. INTRODUCTION	6
4. OPERATION	7
5. APPLICATION NOTES	11
6. SPECIFICATIONS/BLOCK DIAGRAM	14

SAFETY INSTRUCTIONS

WARNING

"READ BEFORE OPERATING"

1. Read Instructions—All the safety and operating instructions should be read before the appliance is operated.
2. Retain Instructions—The safety and operating instructions should be retained for future reference.
3. Heed Warnings—All warnings on the appliance and in the operating instructions should be adhered to.
4. Follow Instructions—All operating and use instructions should be followed.
5. Water and Moisture—The appliance should not be used near water—for example, near a bathtub, washbowl, kitchen sink, laundry tub, in a wet basement, or near a swimming pool, etc.
6. Ventilation—The appliance should be situated so that its location or position does not interfere with its proper ventilation. For example, the appliance should not be situated on a bed, sofa, rug, or similar surface that may block the ventilation openings; or, placed in a built-in installation, such as a bookcase or cabinet that may impede the flow of air through the ventilation openings.
7. Heat—The appliance should be situated away from heat sources such as radiators, heat registers, stoves, or other appliances (including amplifiers) that produce heat.
8. Power Sources—The appliance should be connected to a power supply only of the type described in the operating instructions or as marked on the appliance.
9. Power-Cord Protection—Power-supply cords should be routed so that they are not likely to be walked on or pinched by items placed upon or against them, paying particular attention to cords at plugs, convenience receptacles, and the point where they exit from the appliance.
10. Cleaning—The appliance should be cleaned only as recommended by the manufacturer.
11. Nonuse Periods—The power cord of the appliance should be unplugged from the outlet when left unused for a long period of time.
12. Object and Liquid Entry—Care should be taken so that objects do not fall and liquids are not spilled into the enclosure through openings.
13. Damage Requiring Service—The appliance should be serviced by qualified service personnel when:
 - A. The power-supply cord or the plug has been damaged; or
 - B. Objects have fallen, or liquid has been spilled into the appliance; or
 - C. The appliance has been exposed to rain; or
 - D. The appliance does not appear to operate normally or exhibits a marked change in performance; or
 - E. The appliance has been dropped, or the enclosure damaged.
14. Servicing—The user should not attempt to service the appliance beyond that described in the operating instructions. All other servicing should be referred to qualified service personnel.

WARNING: To avoid possible electric shock hazard, do not expose this appliance to rain or moisture. There are no user serviceable parts inside. Refer servicing to qualified service personnel.

FRONT PANEL

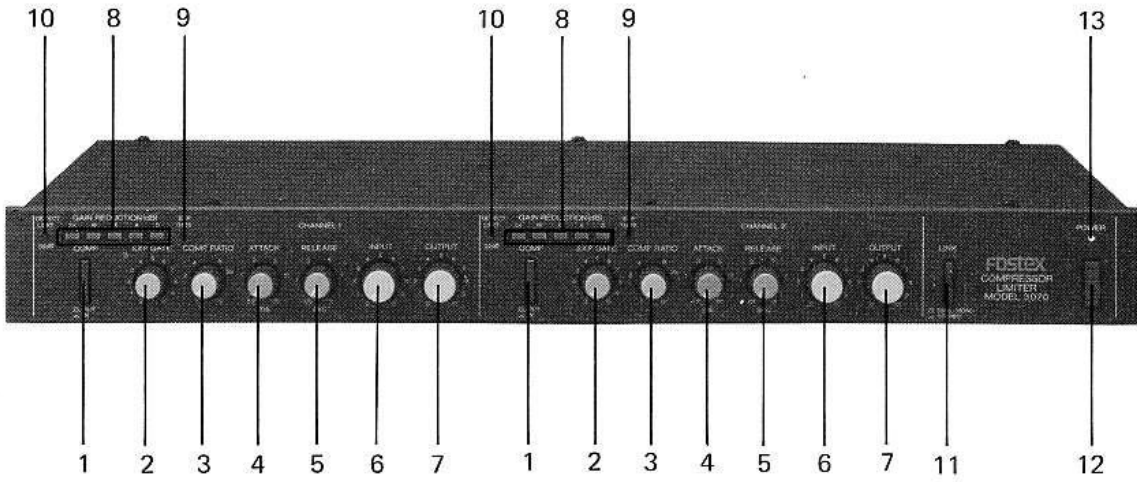

REAR PANEL

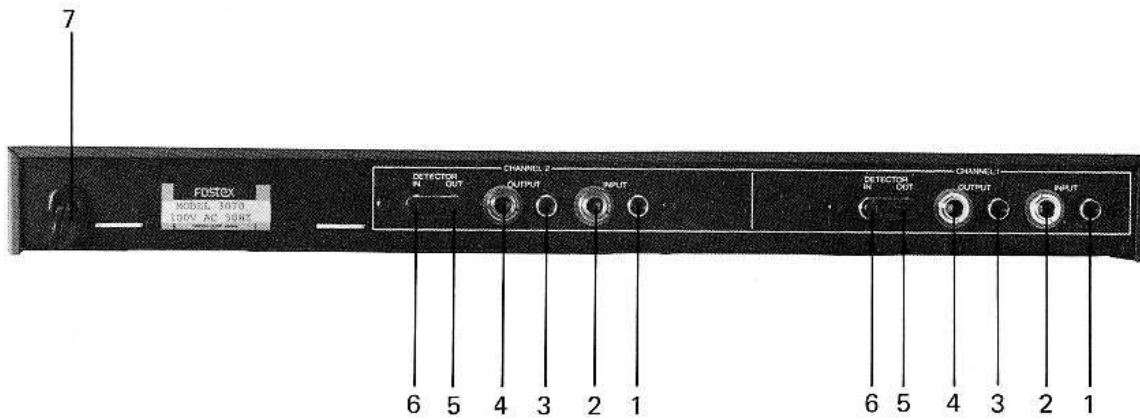

1. LOCATION OF CONTROLS (Front panel)

(1) COMP IN/OUT

This push-type switch determines whether the input signal will be processed (IN) or bypass the circuit (OUT). When this switch is OUT, all function controls on the front panel are disabled, and the input signal will then appear at the output jacks, unaltered.

(2) EXP GATE

When this rotary control is fully CCW, there is a click action indicating the OFF position. As the control is rotated CW, the threshold level for the gating function increases accordingly.

(3) COMP RATIO

This rotary control changes the compressor ratio continuously from 1:1 (no limiting) through ∞ :1 (hard limiting). As a reference, consider two extreme settings:

A. Set to a scale of 2, the change in output level will be 1dB for an input signal 2dB higher than the threshold, and the "0" LED (reference (8) GAIN REDUCTION) will be lit.

B. Set to ∞ , there will be no change in output level for input signals higher than the threshold. When the DETECT LIMIT LED (reference (10)) flashes, the maximum gain reduction will be 32dB.

(4) ATTACK

The signal level of the compressor is controlled by an internal VCA (Voltage Control Amplifier). The response time of that VCA is determined by this rotary control, which is continuously variable from 0.2 through 20 msec.

(5) RELEASE

The amount of time it takes the control circuit to recover from processing and return to unity gain is determined by setting this continuously variable rotary control from 50 msec. through 2 sec.

(6) INPUT

Due to unique design efficiencies this rotary control performs two functions simultaneously. While the threshold level at the input of the VCA detect circuit is fixed at about -18dBV (0.13V), by varying the input level you effectively vary the threshold level. The total amount of gain reduction is determined by the setting of the compression ratio slope and this input level control.

At a nominal -10dBV line level reference, the threshold is obtained with the INPUT knob at scale 3 ~ 4, and most of the audio signal is passing unprocessed (linear response). See Figure 1.

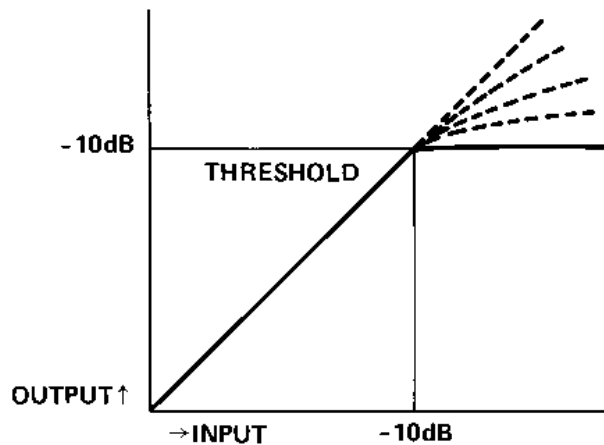

Fig. 1

With the compressor ratio slope set at $\infty:1$ it is likely that the detect limit LED will light, indicating 32dB of gain reduction. It should be noted that this LED does not indicate overload of the audio signal; there is an additional 32dB of system headroom before the compressor/limiter circuit overloads.

(7) OUTPUT

This rotary control is for adjusting the output level of the processed signal. In a nominal scale position of 4 to 5, referenced to -18dBV at the detect circuit input, the signal level present at the output jacks will be -10dBV (0.3V).

(8) GAIN REDUCTION (dB)

This series of five LED's displays the amount of gain reduction in calibrated decibel readings at 0, 4, 8, 16 and 24. These diodes will not light when the COMP switch is in the OUT position.

(9) EXP GATE

This LED lights when the expander/noise gate circuit is in use, and when the signal present is below the threshold (determined by the setting of the EXP GATE control (2)). When this LED turns off, the signal present is above the threshold setting and is being processed accordingly.

(10) DETECT LIMIT 32dB

When this LED lights, maximum gain reduction of 32dB has been reached. It also indicates that the detect circuit is overloading and can no longer control the operation of the VCA on a one-to-one basis. Please note that there is 32dB more system headroom above the overload point of the detect circuit, so this LED does not indicate distortion of the audio signal.

(11) LINK

When this switch is in the DUAL MONO mode (UP), the front panel controls for each channel will operate independently. In the STEREO mode (DOWN), VCA operation is linked and both channels will be processed together.

NOTE: The VCA will link with EXP GATE controls via the detect signal from the channel which is set at the higher threshold level. Both controls must be ON for stereo operation of the expander/noise gate function; if either control is OFF, single channel operation results. Turn both controls OFF if you do not require this function for stereo processing.

(12) POWER

ON/OFF switch for the 3070 with LED power ON indicator.

2. LOCATION OF CONNECTIONS (Rear panel)

(1) INPUT - Pin jack

Input levels here which will raise the gain to threshold level are: (A) 0dB (1V) with the input level control at full CCW position; and (B) -36dBV (16 mV) at full CW position.

(2) INPUT - Phone jack

There is a 10dB pad at this jack, so it can accept an input signal 10dB higher than the pin jack. Thus, input levels here which will raise the gain to threshold level are: (A) +10dB (3V) with the input level control at full CCW position; and (B) -26dBV (50 mV) at full CW position.

(3), (4) OUTPUTS

The pin jack (3) and the phono jack (4) are wired in parallel.

(5), (6) DETECTOR IN-OUT

This patch point gives you access to the detect circuit which controls the VCA operation of the compressor/limiter circuit. By inserting other processors such as equalizers, or audio signals themselves such as vocals, a limitless variety of creative effects can be produced.

(7) AC Power Cord

3. INTRODUCTION

The Fostex Model 3070 Compressor/Limiter Unit is designed for wide applications in the process of compression and limiting.

The key is operational flexibility because the program material itself will always be a significant factor in determining the ultimate use of the Model 3070.

And in this reason, the compressor slope, attack time and release time are all continuously variable.

The noise gate function has an independent threshold setting like having another signal processor in the same chassis.

You can choose between independent 2-channel operation or linked stereo mode where the stronger of the two signals triggers processing, thereby preserving original stereo imaging.

One of the most outstanding features of the Model 3070 is the control element. Gain reduction is accomplished by a VCA circuit which is controlled by pulse width modulation.

By varying the length of time an internal electronic switch is open or closed during each cycle, signal energy is reduced without distorting the program.

You have also an access to the detect circuit which controls the VCA operation (rear panel patch points). A vocal or instrument (or equalizer, etc.) connected directly to the detect circuit turns the Model 3070 into a creative audio tool whose sonic possibilities are limitless.

4. OPERATION

The following is a simplified explanation of the operating technique behind the 3070 compressor/limiter with expander/noise gate function.

With no compression or gain reduction, the ratio of input level to output level, other parameters being equal, would be linear. See Figure 2.

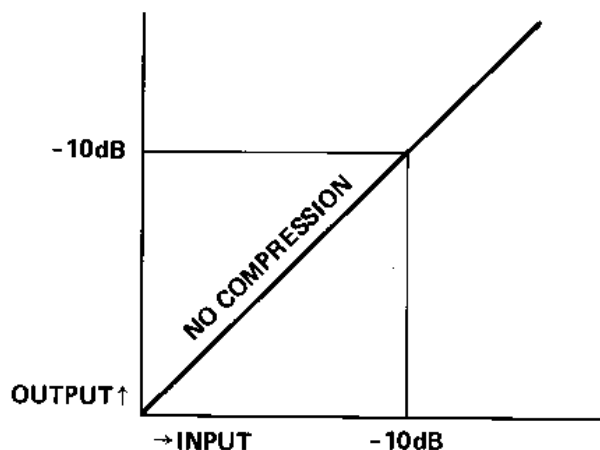

Fig. 2

One of the most outstanding features of the 3070 is the control element. Gain reduction is accomplished by a VCA circuit, which is controlled by pulse width modulation.

In the VCA circuit there is an electronic switch which opens and closes at a rate of 200KHz. By varying the length of time this electronic switch is open or closed during each cycle, signal energy is reduced without distorting the program.

An important benefit of this type of circuit is lower distortion. Continuous low frequency response, especially, is much lower in distortion than typical units when the attack time is set fast. For this reason you have more latitude in the use of the release control, without worrying about gross pumping and breathing effects.

Finally, the detect circuit which controls the VCA operation is externally accessible on the 3070. There really are no rules or theory of operation here, you are in the realm of creative audio effects. Personal taste is the determining factor.

With an infinite compression ratio, hard limiting results, an effect that can sometimes be harsh to the ear, because right at the threshold level, any more input increase yields no more output level. See Figure 3.

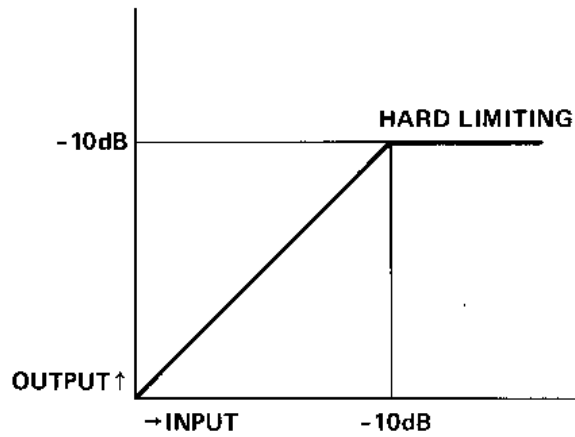

Fig. 3

In between zero compression and infinite compression is a continuously variable compression ratio with typical response patterns as shown in Figure 4.

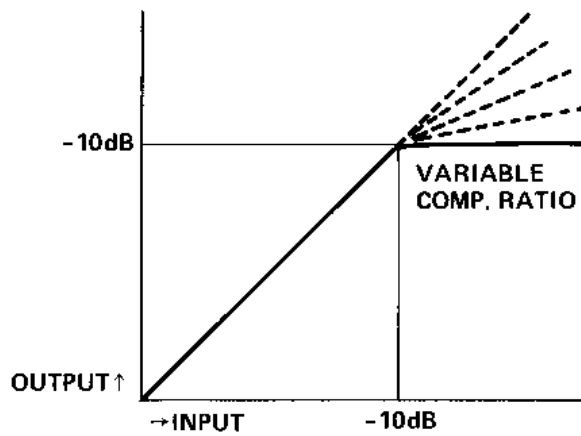

Fig. 4

By adjusting attack and release characteristics, these typical compression curves can be altered radically, as in Figure 5, below. A small, mV signal produces the same maximum output level as a large signal. This effect similar to automatic gain control (AGC), can be quite useful for live recording and PA applications.

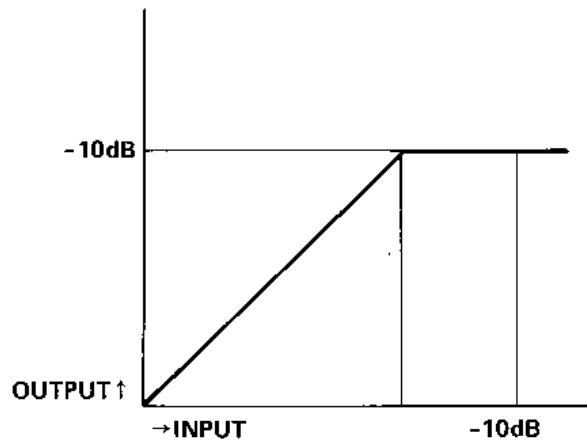

Fig. 5

Expansion is simply the inverse equivalent of compression. The algebraic addition of the two curves shown in Fig. 6 would be linear.

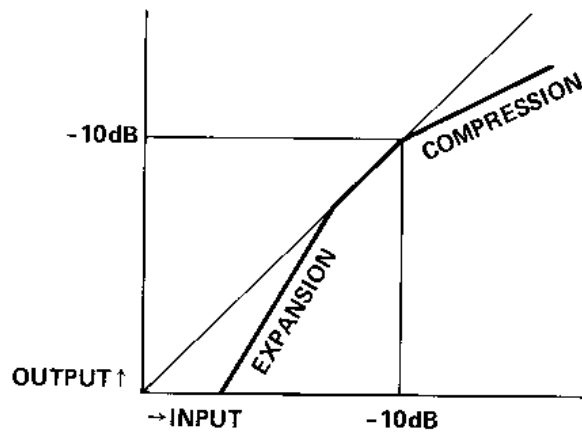

Fig. 6

A relationship exists between limiting and gating as well, although each has its effect at opposite ends of the dynamic range, as shown in Figure 7.

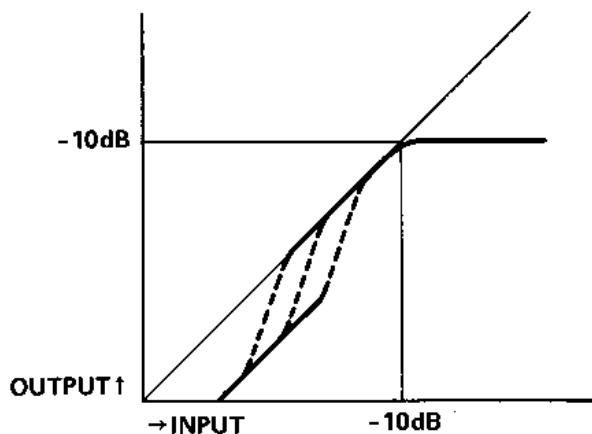

Fig. 7

In terms of electronics, all these concepts are closely related, but in terms of application the differences are pronounced.

5. APPLICATION NOTES

(1) Attack and Release

The attack is the speed with which the gain reduction circuitry comes into action.

The Release is the time it takes the noise reduction circuitry to return to its nominal setting after the signal returns to below threshold.

The setting of these controls will likely have a more audible and pronounced effect over the processed signal than, for example, the compressor ratio control settings. The interactive use of attack and release times is immediately apparent, so you will know instantly whether you have the effect you want.

(2) Automatic Blend

A common technique for bringing a vocal into an instrumental mix is to fade the mix slightly as the vocal is brought up. Usually a manual practice is required, and sometimes many re-takes are necessary to get it right. Try the 3070 this way: set the level of the music mix just below the threshold level of the 3070; now if the vocal comes in 5 or 10dB hotter, the compressor will reduce the gain of the vocal while automatically reducing the level of the music mix.

(3) Acoustic Piano

Sometimes it's hard enough getting the right acoustic piano sound from your mics, only to find the dynamics lost in the mix. With the 3070 you can accentuate the attack for an effective "punchy" sound, and any natural "room" sound that lingers after a note stops ringing can be emphasized by the release control setting to amplify the decay. (This is the principle behind guitar sustain.)

(4) Low Frequency Definition

By nature, of course, low frequencies lack definition. But a judicious use of the 3070 can go a long way in separating the kick drum from the bass guitar, for example, during the mix. By using different compression ratios and/or different attack/re-

lease characteristics, you have more control over the inter-relationships of the instruments within the low frequency spectrum.

(5) Vocals

Even with trained voices, good microphones and good microphone technique, getting a good vocal recording that pleases both artist and engineer is sometimes very difficult. One reason is that vocals usually contain many peaks and transients, but maintain relatively low average levels. The compressor/limiter helps not only to contain the sharp transients but also to raise the average level for a more consistent blend with the music.

(6) Link

Depending on the program material, you will probably find that the processing of stereo signals with the 3070 in the dual mono mode (UP) gives you more control over the final imaging of the stereo effect. In the stereo mode (DOWN) the stronger signal of the stereo pair will trigger the processing, as determined by the settings of that channel. Among the several uses for this mode are cleaning up 2-track tapes where you want to preserve the original stereo balance, and making "fail safe" cassette copies during mixdown. See Figure 8.

(7) Noise Gate Functions

Any open microphone, whether on a vocalist or a floor tom, adds unnecessary noise when no signal is being passed. The insertion of a noise gate immediately after the mic preamp is a common practice to guard against noise build up. This same principle also holds true during mixdown. Patch the 3070 to two channels which go in and out of the mix, set the threshold levels, and you've just saved yourself four manual fader changes per in/out incident.

Use the noise gate with the compressor to handle noisy guitar or keyboard amps. Set the gate threshold level so that when no signal is present, the channel is off (thereby eliminating

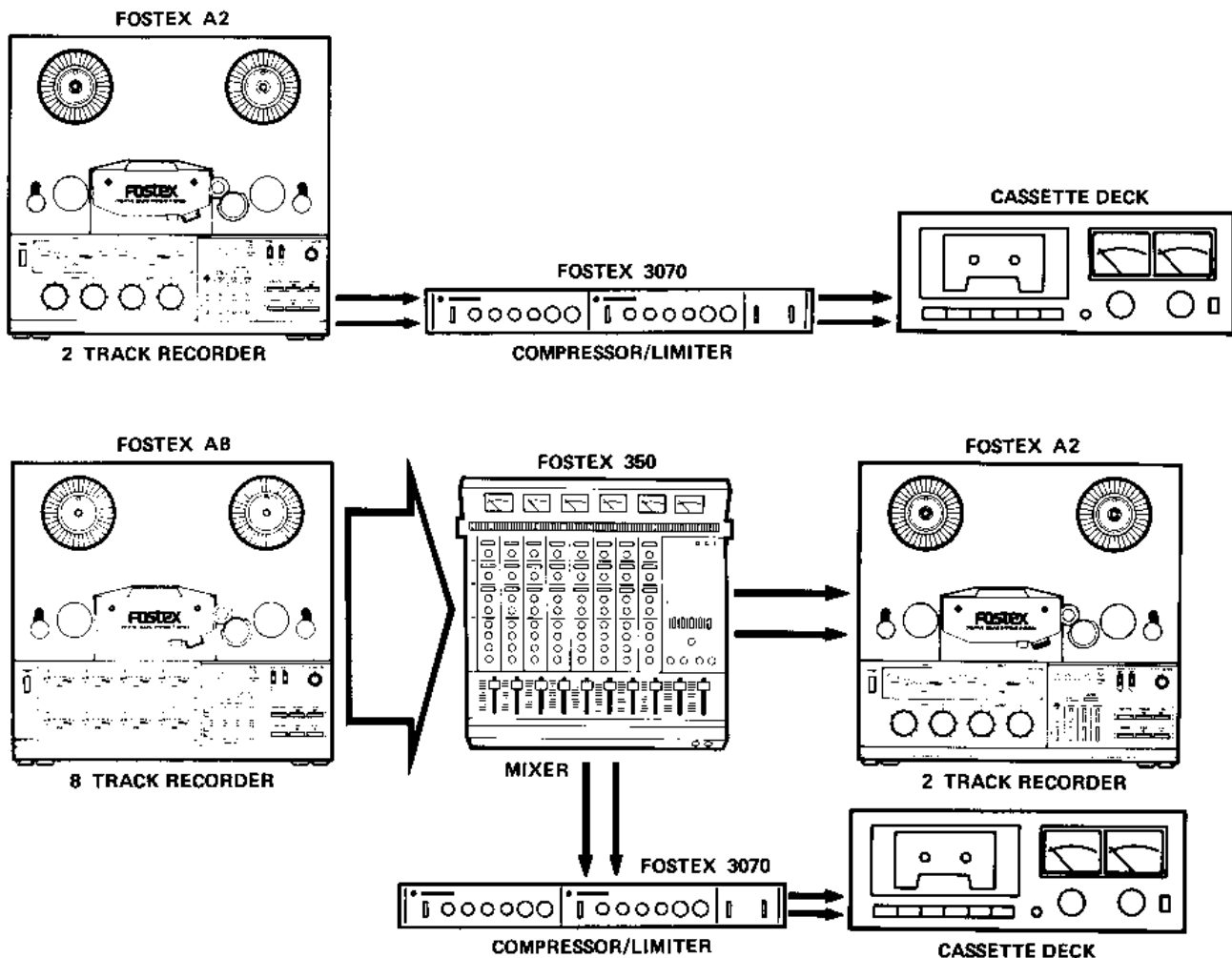

Typical uses of link mode to preserve original stereo imaging.

Fig. 8

the amplifier noise). Then set the compression ratio and attack such that as soon as the instrument is played, the level of both noise and signal is raised to the point where normal masking effects take place and the signal predominates.

In short, overall system noise as well as specific noise problems can be efficiently reduced and effectively eliminated by the 3070.

(8) Creative Effects

One of the fun aspects of the 3070 is this accessibility to the detect circuit which controls the VCA. You may have had the creative urge to equalize the signal before compression. Now

you'll be able to experiment by using the equalizer to trigger the compressor, so that only selected frequencies, for example, are processed by the 3070.

Another, more familiar effect is perhaps best described as "vocal punch-through," where a lead vocal suddenly seems to break through a loud crescendo or a "wall of sound." By connecting the vocal mic directly to the detector circuit of the 3070, the vocalist now controls the compression circuit.

Other signals, sub-mixes, instruments and music can be set to control the VCA for a limitless variety of audio effects. And while creativity can be wildly imaginative, it can also be very practical.

Consider the following use of the detector circuit: Suppose you want a keyboard to come up in level as soon as the guitar solo ends (and who knows when that will be). Just patch the guitar to the detector in/out and adjust the controls so that you have, effectively, an automatic cross fade.

Since this is a novel feature open to infinite creative possibilities, we would be genuinely interested in learning about your particular success in using this circuit.

For that matter, if you find a particular sound with the 3070 that you think is great, please send us the details and we'll be happy to pass the information along to other people like you who are interested in getting the most out of today's technology.

6. SPECIFICATIONS/BLOCK DIAGRAM

Input	Unbal. Phono jack and Phone jack
Input Impedance	30 Kohms
Input Level	+30 dBV(30V) max
Output	Unbal. Phono jack and Phone jack
Output Load Imp.	5 Kohms or higher
Max. Output Level	+18 dBV(8V)
Gain	30 dB
Comp./Limit Ratio	1:1 — inf.:1, Variable comp. ratio

Max. Limiting	32dB (from threshold level when Inf.:1)
Attack time	0.2 — 20 msec., continuously variable
Release Time	50 msec — 2 sec., continuously variable
Frequency Response	20 Hz — 20 KHz \pm 1 dB
T.H.D.	Less than 0.03% below threshold Less than 0.1% with 20 dB limiting
Signal to Noise Ratio	80 dB unwt'd, ref. to threshold level 82 dB wtd., ref. to threshold level
Slew Rate	10V/usec
Power Requirements	120V AC, 60 Hz, 12W (U.S.A./Canadian models) 220V AC, 50 Hz, 12W (European models) 240V AC, 50 Hz, 12W (UK/Australian models) 100/120/220/240V AC, 50/60 Hz, 10W (General export models)
Dimensions	17" (W) x 1-3/4" (H) x 8-1/4" (D) [430 (W) x 44 (H) x 210 (D)mm]
Weight	Net 6-1/2Ibs (2.9Kg) Shipping 7-1/4Ibs (3.3Kg)

* Specifications subject to change without notice.

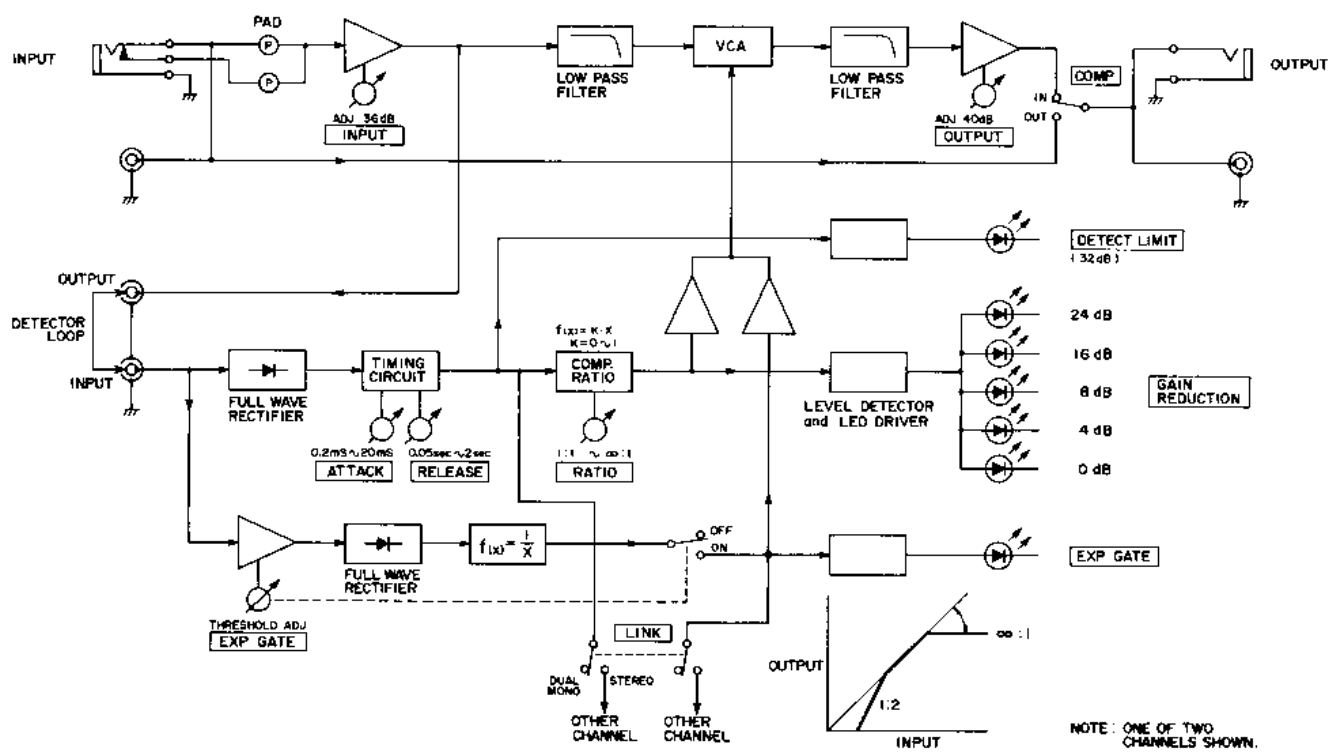

Fostex

FOSTEX CORPORATION 512, Miyazawa-cho, Akishima, Tokyo, Japan

FOSTEX CORPORATION OF AMERICA 15431, Blackburn Ave., Norwalk, CA 90650, U.S.A.

©PRINTED IN JAPAN OCT. 1982 8288 0480 00