

HiFi ENGINE®

For more Hi-Fi manuals and set-up information
please visit www.hifienzyme.com

TEAC

1. GENERAL DESCRIPTION

SERVICE MANUAL A-3440

4-Channel Multitrack Tape Deck with SIMUL-SYNC



TEAC CORPORATION

5103238502

1. GENERAL DESCRIPTION

The TEAC A-3440 is a 4 channel, multi-track open reel tape deck which operates at 15 ips and 7-1/2 ips.

The A-3440 is a development of the well known A3340S and shares many features in common. Specifically, the transport section is virtually the same though there has been extensive redesign of the controls and the electronics. The FUNCTION SELECT switches, together with the OUTPUT SELECT switches provide instant selection of source, sync and normal off-tape monitoring. There is a rear panel interface for the RX-9 DBX noise reduction unit, the use of which will greatly improve the dynamic range and signal to noise performance of the deck.

The A-3440 is ideally suited to the requirements of the musician and multi-track recordist.

If any of the procedures in this manual are not sufficiently clear, or seem too difficult to undertake, we suggest you contact your nearest TEAC Factory Service Department or write directly to the TEAC Corporation. TEAC addresses are printed on the back cover of this manual.



– TABLE OF CONTENTS –

1. GENERAL DESCRIPTION	3
2. SPECIFICATIONS AND SERVICE DATA	4
3. TOOLS FOR TESTING AND MAINTENANCE . . .	5
4. PARTIAL DIS-ASSEMBLY	6
5. TAPE TRANSPORT PARTS LOCATION	9
– Rear View –	
6. HEAD REPLACEMENT AND ALIGNMENT . . .	10
– Mechanical –	
7. MEASUREMENT AND ADJUSTMENT	12
– Mechanical –	
8. MEASUREMENT AND ADJUSTMENT	16
– Electrical –	
9. SERVICING AND MAINTENANCE	23
10. SIMPLIFIED SCHEMATIC AND LEVEL DIAGRAMS	24
11. TEAC DECIBEL TABLES	25

2. SPECIFICATIONS AND SERVICE DATA

2-1 SPECIFICATIONS

Track System	4 channel Multi-track SIMUL-SYNC
Heads	Erase, Record/Sync and Playback
Reel Size	10-2/1" and 7"
Tape Speed	15 ips and 7½ ips
3 Motors	1 DC-Servo Capstan Motor 2 Eddy current induction Reel motors
Inputs (Level and Impedance)	MIC: Specified; -60 dB (775 μ V)/10k ohms Minimum; -70 dB (245 μ V) MIC (ATT = 0 dB) position LINE: Specified; -12 dB (195 mV)/50k ohms Minimum; -22 dB (61.5 mV)
Outputs (Level and Load Imp.)	LINE: Specified; - 8 dB (308 mV)/10k ohms Maximum; - 2 dB (615 mV) HEADPHONE: -19 dB (86.9 mV)/4 ohms, one channel ON (MONITOR VR Max.) - 6 dB (388 mV)/4 ohms, all channels ON SIMUL-SYNC Out: - 8 dB (308 mV)/10k ohms
Playback Equalization	15 ips: 3180 μ s + 50 μ s 7½ ips: 3180 μ s + 50 μ s
Bias Frequency	100 kHz \pm 5 kHz (push-pull oscillator)
Power Requirement and Consumption	

Model	Voltage (V)	Frequency (Hz)	Consumption (W)
General Export	100/117 220/240	50/60	125
EUR	220	50	120
UK/AUS	240	50	120
USA/CND	117	60	125

Weight	24 kg (53 lbs) net
Dimensions (WHD)	445 x 523 x 235mm (17½" x 20½" x 9¼")

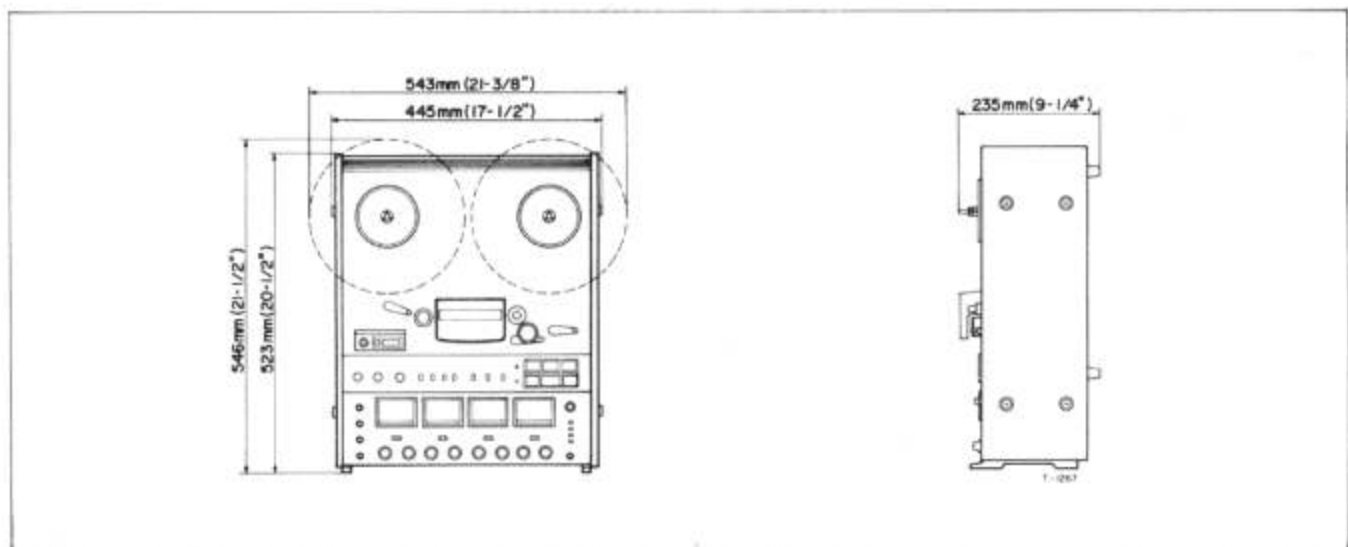

Fig. 2-1 Dimensions

2-2 SERVICE DATA —MECHANICAL—

Tape Speed Deviation and Drift	3000 Hz \pm 30 Hz, within 15 Hz
Wow and Flutter	Playback: 0.10% (WRMS) at 15 ips 0.12% (WRMS) at 7½ ips Overall: 0.15% (RMS) at 15 ips 0.18% (RMS) at 7½ ips
Pinch Roller Pressure	2.2 kg (4.8 lbs)
Reel Torque	Take-up: LARGE 770 to 830 g-cm (11 to 12 oz-inch) SMALL 370 to 410 g-cm (5.2 to 5.7 oz-inch) Back Tension: LARGE 330 to 390 g-cm (4.6 to 5.5 oz-inch) SMALL 180 to 220 g-cm (2.5 to 3.1 oz-9inch)
F.F./REW Torque	2000 g-cm or more (28 oz-inch)
Brake Torque	1400 to 1800 g-cm (20 to 25 oz-inch)
F.F./REW Time	140 seconds for 1800 ft tape

2-3 SERVICE DATA —ELECTRICAL—

Frequency Response	Refer to Frequency Response Limits charts on page 18, 20 and 22.
Signal-to Noise Ratio	Overall: 45 dB at 15 ips 46 dB at 7½ ips Playback: 50 dB at both speeds SIMUL-SYNC: 40 dB at both speeds
Erase Efficiency	65 dB at 1 kHz signal (Measurement with input 10 dB higher than the specified Input level)
Stereo Channel Separation	40 dB channel to channel at 1 kHz signal
SIMUL-SYNC Channel Separation	45 dB channel to channel at 1 kHz signal
SIMUL-SYNC Crosstalk	8 dB, or more.
Total Harmonic Distortion	Overall: 1.0% at 1 kHz signal at 0 VU

NOTE: As a result of containing changes and improvements during the production run, minor differences may be found between early and later machines.
Value of "dB" in this manual refers to 0 dB = 0.775 V.

3. TOOLS FOR TESTING AND MAINTENANCE

A minimum of the following tools and test instruments are required for measuring and adjusting to obtain optimum performance. Regular maintenance tools will be adequate for those not listed here. If any test instrument listed here is not available, a close equivalent can be used.

SPRING SCALE:	0—4 kg (0—8 lbs) 0—300 g (0—10 oz)	TEAC TEST TAPE:	YTT-1004 (15 ips), YTT-1003 (7½ ips) for Playback Alignment test, YTT-2003 (7½ ips), YTT-2004 (15 ips) for Tape Speed and Wow and Flutter test.
FLUTTER METER:	Meguro Denpa Sokki K.K., Model MK-668C	TEAC EMPTY REEL:	RE-702 (2.5" dia. hub) RE-701 (4" dia. hub)
DIGITAL COUNTER:	Range; 0 Hz—100 kHz	TOOLS:	2 mm nut driver, Hex Head Allen Wrench, Plastic alignment tool, Load resistor non inductive type 4 ohm/1 W.
BANDPASS FILTER:	TEAC MODEL M-206A (1 kHz)	DEMAGNETIZER:	TEAC E-3 or equivalent.
VTVM (AC):	Hewlett-Packard Co., Model 400E		
AF OSCILLATOR:	10 Hz—100 kHz		
ATTENUATOR:	General purpose		
OSCILLOSCOPE:	General purpose		
BLANK TAPE:	TEAC YTT-8013		

4. PARTIAL DIS-ASSEMBLY

4-1 OUTER CASE AND PANEL REMOVAL

Remove panels as required as shown in the illustration.

Unplug the power cord before removing any panel or internal part.

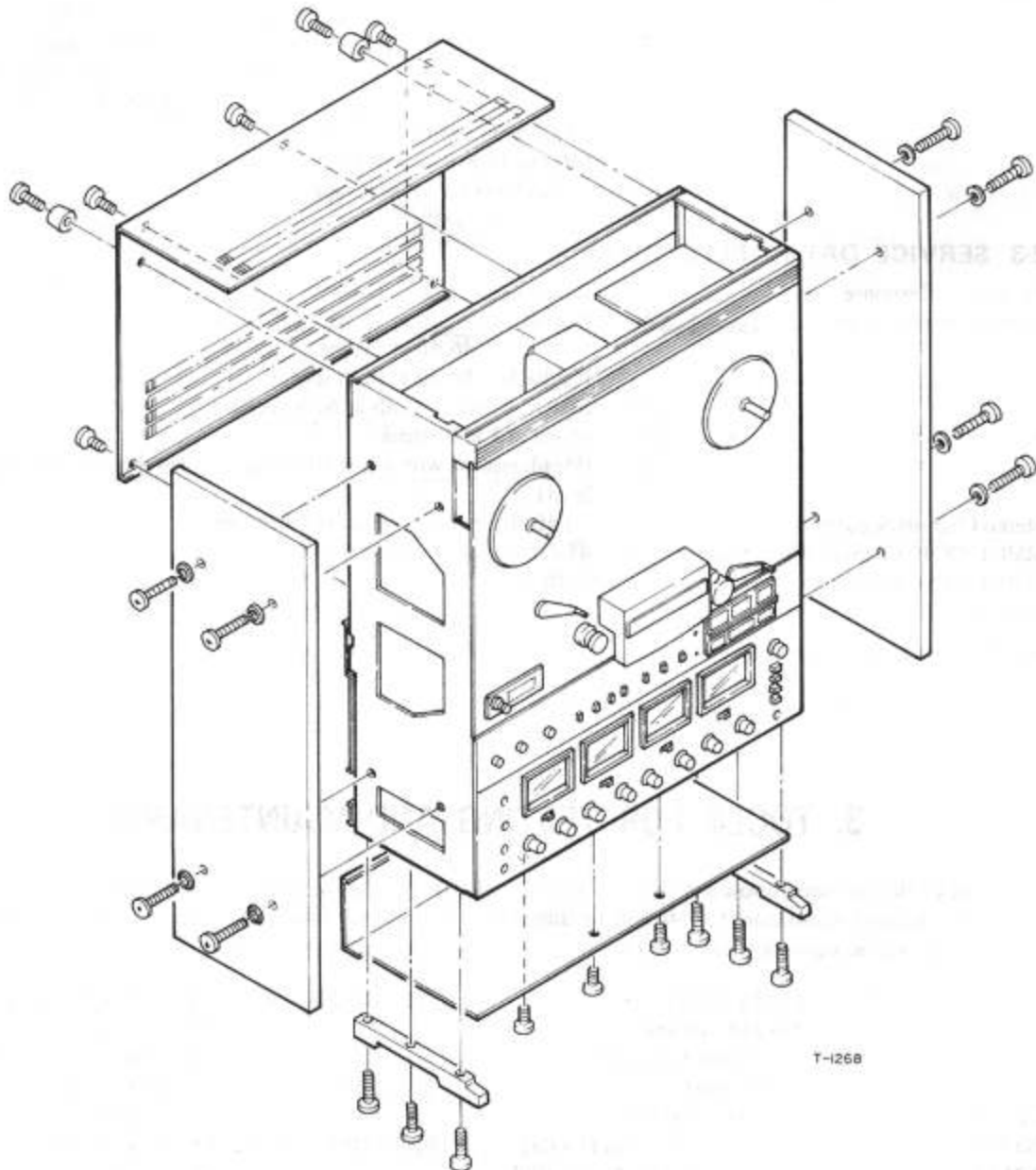
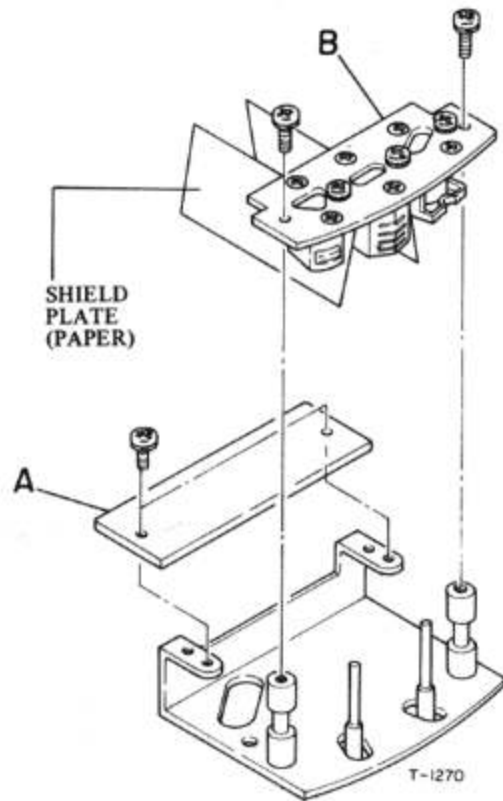

Fig. 4-1 Outer Case and Panel Removal

4-2 HEAD ASSEMBLY REMOVAL

1. Remove the 2 screws in the top of the head Cover and lift it off.
2. Remove 2 screws holding Head P.C.B. (A).
3. Remove 2 screws holding Head Base Plate (B) (with head).
4. Remove 2 mounting nuts through access slot in head base plate and dis-connect head wire. Refer to page 10 and 11.



4-3 TENSION ARM REMOVAL

— RIGHT TENSION ARM —

1. Remove Spring (E) from Switch-off Drum (D).
2. Remove set screw holding Switch-off Drum (D), and remove (C) and (D).
3. Remove NUT holding Right Arm Holder (B), and lift off Right Tension Arm (A).

— LEFT TENSION ARM —

1. Remove 2 screws holding plate (L) and Lift off Friction spring (J) and spring (K).
2. Remove spring (H) from Tension Arm Stopper (I), and remove Tension Arm Stopper by set screw.
3. Remove NUT holding Left Arm Holder (G), and lift off Left Tension Arm (F).

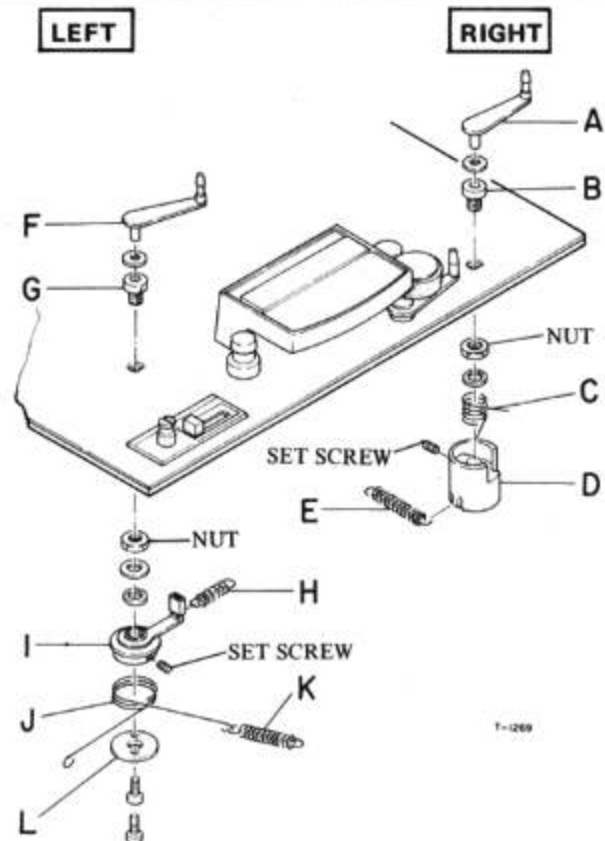

4.4 REEL MOTOR REMOVAL

1. Remove Power from Deck.
2. Remove wooden side panels by removing 4 mounting screws each.
3. Loosen 2 set screws (Hex head) in Reel Turntable ass'y (D) and in the Brake Drum (A). Lift off parts.
4. Disconnect the 4 motor wires from terminals and release wire harness straps.
5. Remove 4 screws securing the Brake Ass'y (B) to motor.

NOTE: Take care not to bend the brake band or brake retainer during removal.

6. Remove 4 screws securing Reel motor (C) to chassis through the front panel.

NOTE: When replacing the LEFT Reel motor Refer Right illustration.

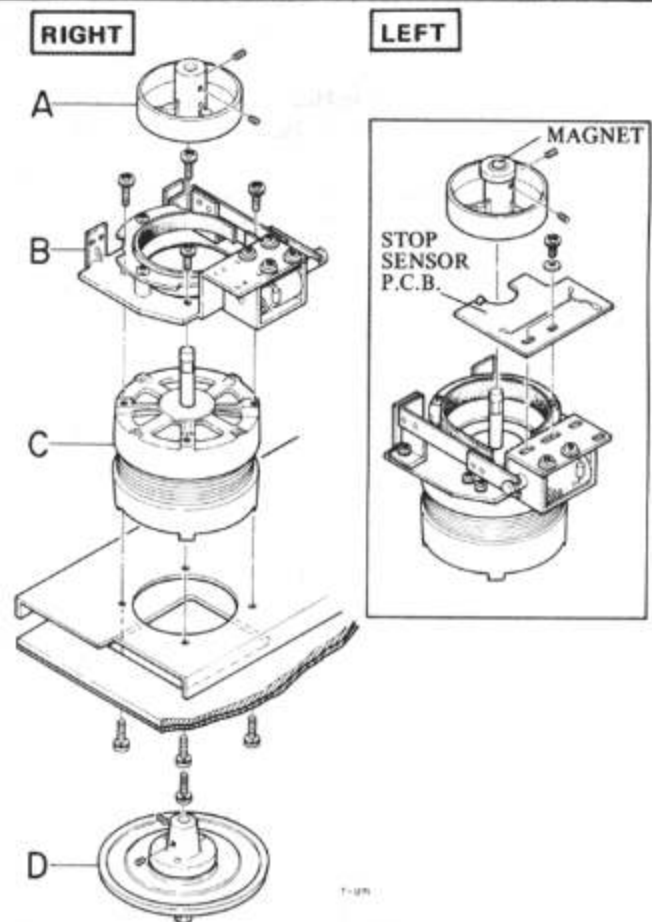

4.5 CAPSTAN MOTOR, FLYWHEEL AND CAPSTAN ASS'Y REMOVAL

1. Unscrew (by hand) the capstan dust cap (H).
2. Remove 2 screws from capstan thrust angle (B) and remove it.
3. Remove flywheel (C) by loosening 2 hex head set screws and removing drive belt (D).
4. Remove Capstan motor (A) with (E) by removing 3 screws.
5. Disconnect 3 screws to Capstan motor from P.C.B.

— CAPSTAN ASS'Y REMOVAL —

6. Remove Arm Support Plate (G) and capstan ass'y (F) by removing 3 screws.

NOTE: When replacing parts make sure belt and capstan shaft are clean and free of oil.

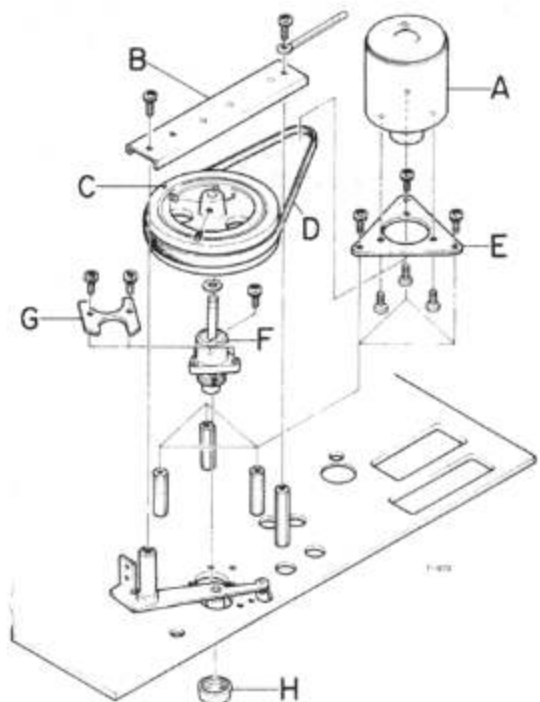

5. TAPE TRANSPORT PARTS LOCATION

— REAR VIEW —

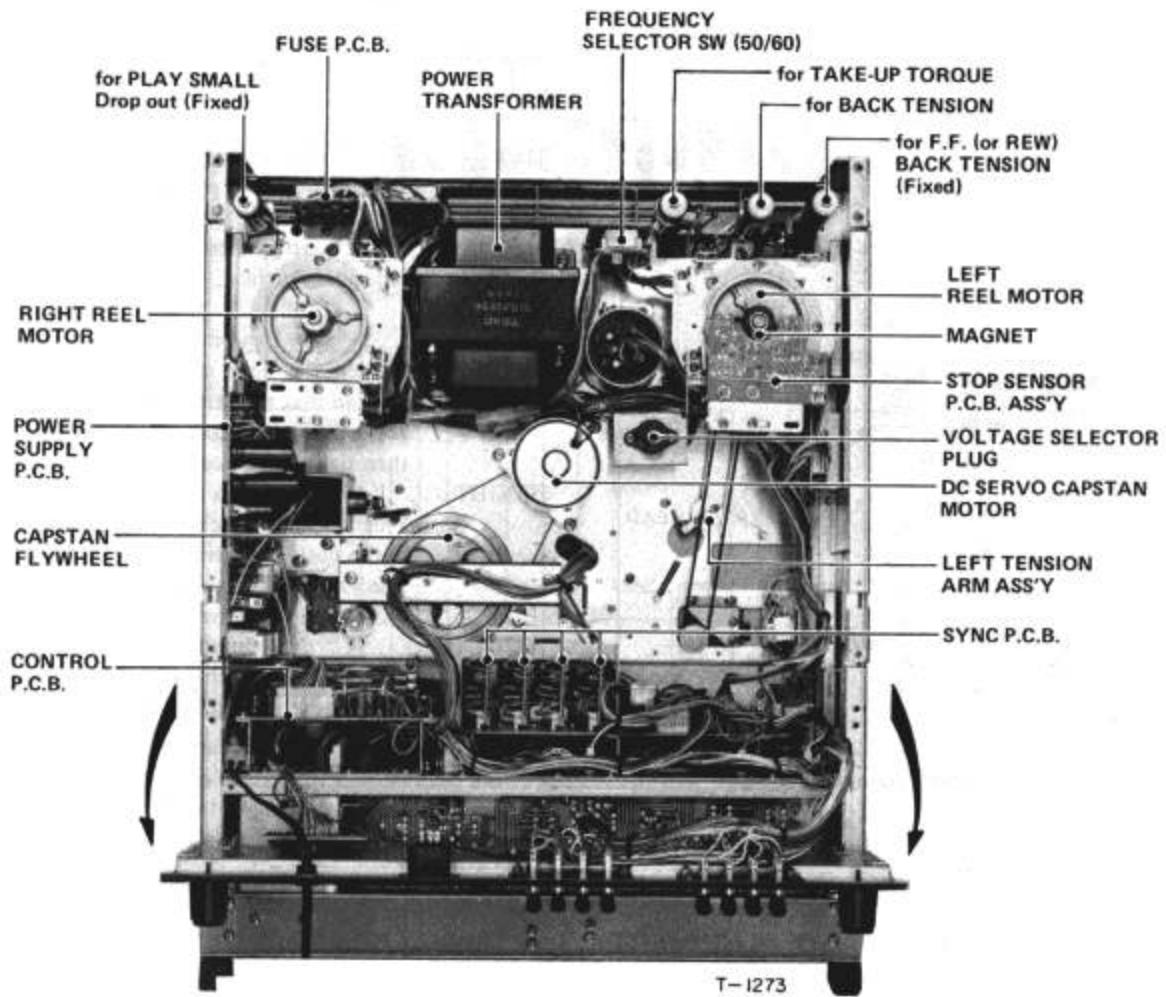

Fig. 5-1 Tape Transport Parts Location

6. HEAD REPLACEMENT AND ALIGNMENT

— MECHANICAL —

6-1 HEAD REPLACEMENT

To replace a single head a special 2 mm nut driver is required. Remove the 2 nuts (A) on the defective head through the access hole provided. This releases the head from the mounting plate. Note the position of the wires on the circuit board. Connect the new head in the same manner. Replace the nuts securing the new head to the plate. Perform head alignment before operation.

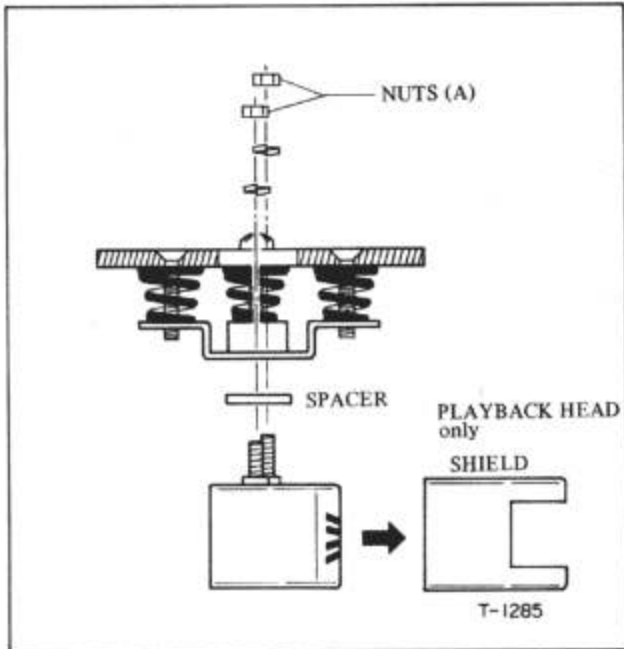

Fig. 6-1 Head Replacement

6-2 HEAD ADJ. SCREWS AND ALIGNMENT

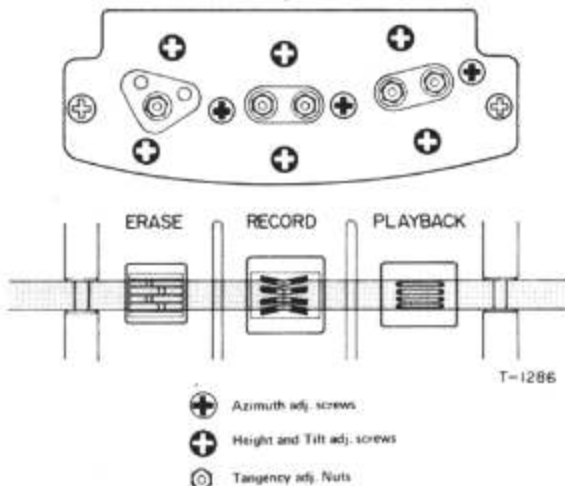

Fig. 6-2 Head Adjustment Screws and Alignment

6-3 VISUAL HEAD ALIGNMENT

Since the head alignment critically affects the frequency response on both playback and recording, the head alignment should be done carefully. The head can be adjusted for TILT, TANGENCY, HEIGHT and AZIMUTH.

For head alignment, perform the following coarse adjustments first. Then fine alignment should be accomplished electrically while playing back the Test Tape.

Coarse Adjustment:

Without Tape

TILT By Height and Tilt screws

This alignment is performed by viewing from the side without tape threaded.

Check that the head surface is parallel to the tape guide surface.

With Tape

TANGENCY By Head mounting nuts

Loosen the head mounting nuts. Adjust the head so that the vertical alignment of the head gap is perpendicular to the surface of the tape, then tighten the head mounting nuts.

HEIGHT By Height and Tilt screws

This alignment is checked visually by looking at the position of the head.

The head core for track-1 (inner core) should be even with the inner edge of the tape.

AZIMUTH By Azimuth adj. Screw

Adjust the azimuth adj. screw so that the gap of the head is perpendicular to the tape travel.

NOTE: After this coarse adjustment is made, the adj. screws and the Head mounting nuts should be realigned according to the electrical head alignment paragraph which follows in this Service Manual.

6-4 MIS-ALIGNMENT OF THE HEADS

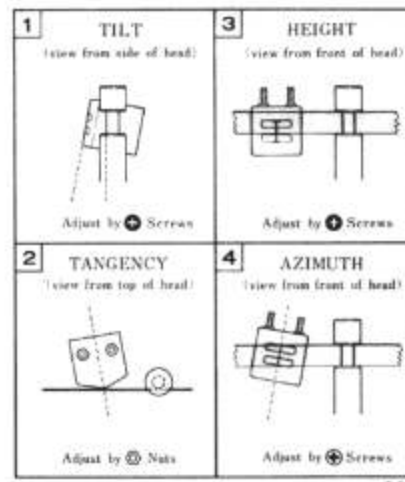
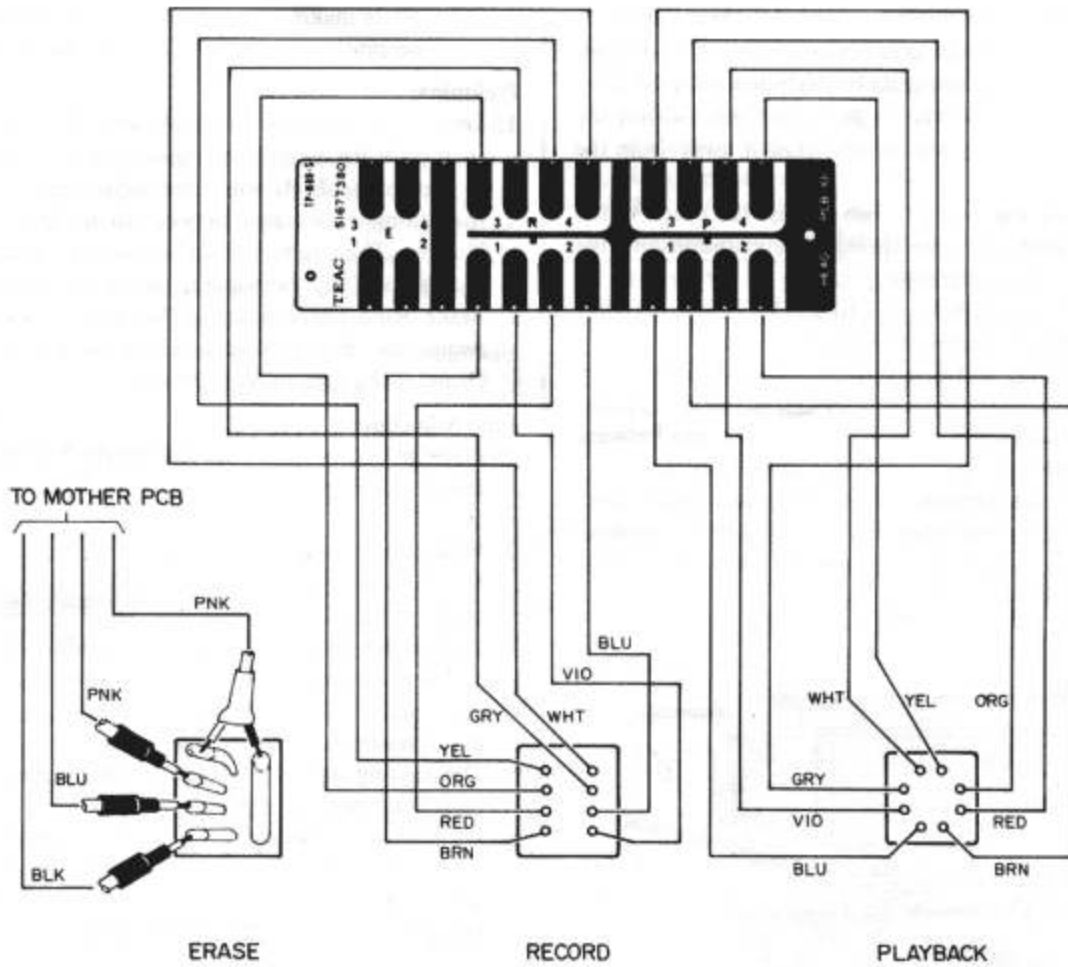

Fig. 6-3 Head Mis-Alignment — Examples —

-HEAD WIRING-



T-1279

Fig. 6-4 Head Wiring

7. MEASUREMENT AND ADJUSTMENT

– MECHANICAL –

7-1 PINCH ROLLER PRESSURE CHECK

NOTE: Pinch roller pressure is supplied by the pinch roller spring arms and it is most important that the solenoid plungers be fully bottomed before taking pressure measurements.

1. Load tape or block the shut-off arm in the ON position.
2. Attach a suitable spring scale to the pinch roller shaft.
3. Place the deck in the Play (▶) mode, and holding the spring scale as illustrated, slowly draw it away from the pinch roller.
4. Do not allow the spring to rub against the pinch roller.
5. Note the reading on the spring scale at the instant the pinch roller stops rotating.
6. The scale should indicate 2.1 to 2.3 kg (4.6 to 6.0 lbs).
7. If adjustment is necessary, loosen the 3 screws on the capstan solenoid and position the solenoid for optimum pressure.
8. Adjust solenoid-limit position so that the gap between capstan shaft and pinch roller is approx. 6 mm when solenoid is not actuated. Also make sure pinch roller shaft does not contact Spring Arm (B). Limit is adjusted by loosening the mounting screw (A), then sliding until proper position is obtained.

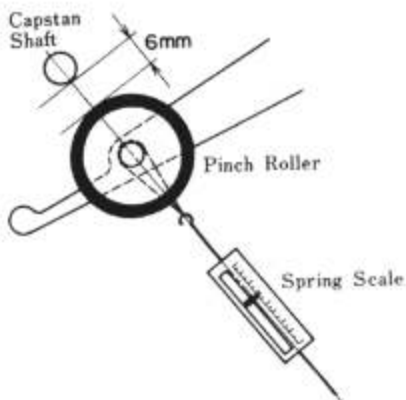
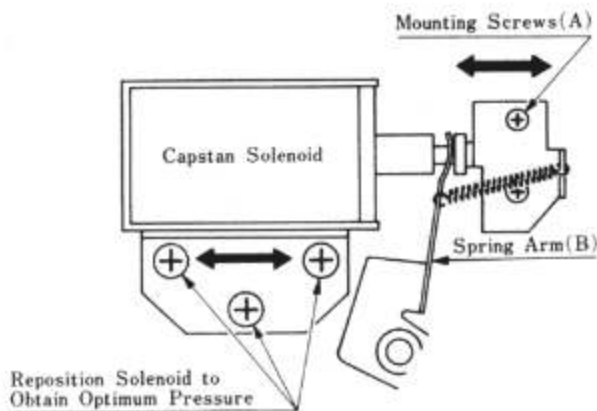

Fig. 7-1 Pressure Measurement and Adj. Location

7-2 BRAKE TORQUE MEASUREMENT

Brake torque measurement is made with Power OFF.

NOTE: The brake torque is actuated mechanically. Torque is set by the variable leaf spring force. While making these measurements and adjustments, be careful not to be bent the brake bands.

Preliminary Adjustments

1. Loosen the screws marked (A) and (B) in the figure and then push the solenoid plunger until it is fully bottomed in the solenoid. At this time adjust the brake solenoid for minimum clearance between Brake Arm and Solenoid Plunger. Then tighten four screws (B). Then, while the plunger is fully bottomed, adjust the position of the Brake Band Space Ass'y so that there is a clearance between the Brake Band and the surface of the Brake Drum. Then tighten two screws (A).

Fine Adjustment

2. Place an empty large hub reel on the left reel table, and fasten one end of a 30" length of string to the reel anchor.
3. Wind several turns of string counter clockwise around the hub and attach a suitable spring scale to the free end of the string.
4. Pull on the spring scale and take a reading only when the reel is in steady motion since the force required to overcome static friction will produce a false, excessively high initial reading.
5. The reading should be 1600 to 2000 g-cm (22.4 to 28.0 oz-inch).
6. If adjustment is required, loosen the 3 screws marked (C) shown and position the brake for optimum pressure.
7. The adjustment of the right brake is the same with the exception that rotations are clockwise. (Wind string Clockwise around reel hub).

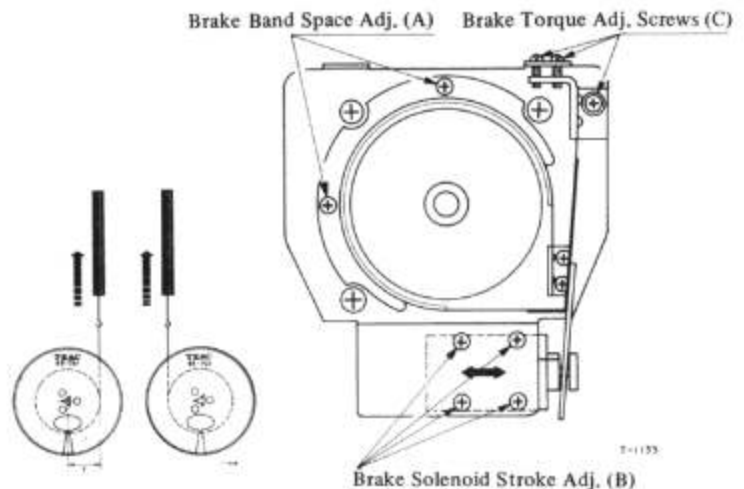

Fig. 7-2 Brake Torque Measurement and Adj. Locations

TORQUE MEASUREMENT PROCEDURE

NOTE: The following torque measurements should be made with a spring scale that is calibrated to read Torque in gram-cm. for a 7" reel with a small reel hub. If the spring scale you are using is calibrated to read Force or Weight in grams the Torque must be calculated using the Formula:

$$\text{Torque (in gm}\cdot\text{cm or oz}\cdot\text{in)} = \text{Weight or Force (in gr. or oz.)} \times \text{radius of hub (in cm or inches)}$$

If you are using a reel with other than the standard 2.5" or 6.0 cm (approx.) diameter hub, the Torque must be calculated using the same formula and substituting the actual radius and Weight or Force reading.

All Torque and Tension measurements must be made with the automatic shut-off switch (right tension arm) held in the ON position.

Brake Torque Measurements should be made using large hub reel with a hub diameter of 4" or 10.2 cm.

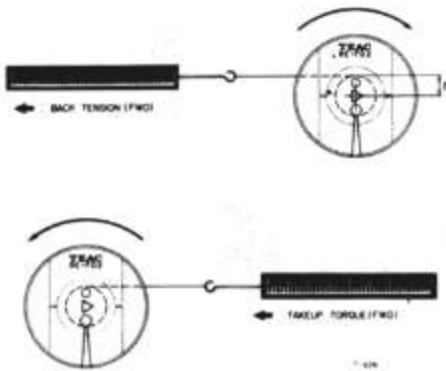

Fig. 7-3 Torque Measurement

7-3 TAKE-UP TORQUE

1. Place an empty reel on the right reel table and attach spring scale.
2. Place the deck in the Play mode.
3. Allow the rotation of the reel to draw the scale slowly towards the hub.
4. Hold the spring scale with enough force to allow a steady reading.
5. **The reading or calculated value should be approx.:**

REEL SW	TAKE-UP TORQUE
LARGE	770 to 830 g-cm (11 to 12 oz-inch)
SMALL	370 to 410 g-cm (5.2 to 5.7 oz-inch)

NOTE: LARGE size value is for reference only.

7-4 BACK TENSION

1. Place an empty 7" reel with small hub on the left reel table and fasten one end of a 30" length of string to the reel anchor.
2. Wind several turns of string counter-clockwise around the hub. Attach spring scale to string.
3. Place the deck in the Play mode.
4. Pull the scale away from the reel against the motor torque with a steady, smooth motion.
5. Note the scale reading while it is in steady motion. (The string must not rub the reel flanges)
6. **The reading or calculated value should be approx.:**

REEL SW	BACK TENSION
LARGE	330 to 390 g-cm (4.6 to 5.5 oz-inch)
SMALL	180 to 220 g-cm (2.5 to 3.1 oz-inch)

NOTE: LARGE size value is for reference only.

Adjustment Location

If necessary, adjust slider of the resistors until you have the correct scale reading for optimum torque. Refer to adj. location below.

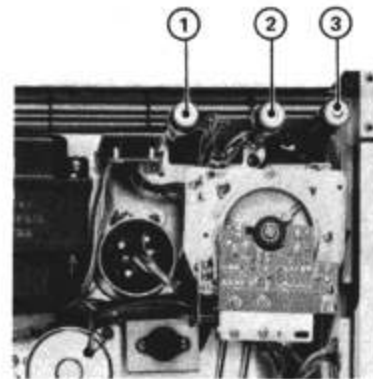

1	for TAKE-UP TORQUE
2	for BACK TENSION
3	for F.F (or REW) BACK TENSION

NOTE: No. 3 for no adjustment provided (FIXED).

Fig. 7-4 Resistors Adj. Location

7-5 FAST FORWARD AND REWIND TORQUE SPECIFICATION

2000 g-cm (28 oz-inch), or more at F.F.
2000 g-cm (28 oz-inch), or more at REW

7-6 MAGNETIC RESISTANCE ELEMENT (STOP SENSER ASS'Y) POSITION ADJ.

1. Adjust Screws for a gap between Magnet and Magnetic Resistance Element of approx. 1 mm.
 2. Check that there is no delay when changing from F.F. (or REW) mode to Play mode.
- Location; on right side when viewed from the rear.

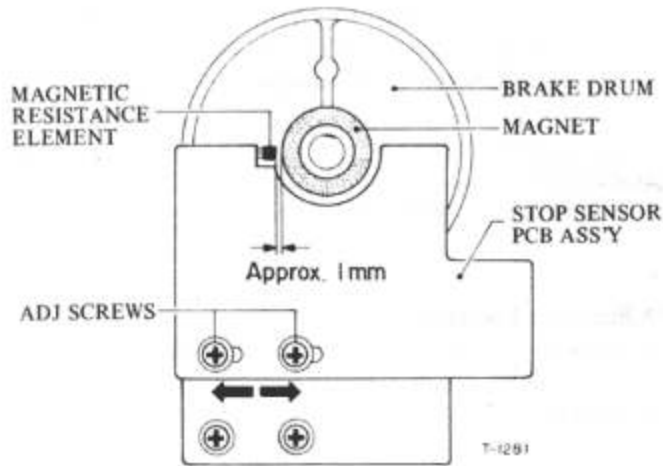

Fig. 7-5 Magnetic Resistance Element Position Adj. Locations

7-8 TAPE SPEED MEASUREMENT

The tape speed should be measured using TEAC flutter free tape, Type YTT-2003 (7½ ips) and YTT-2004 (15 ips). These contain a highly accurate 3000 Hz tone. Connect a digital frequency counter to either line OUTPUT jack. The indicated frequency should be as follow.

Tape Speed Deviation	3000 Hz ±30 Hz	
Drift	Within 15 Hz, or less	
Using PITCH CONT	Max. (+)	3180 Hz to 3450 Hz
	Min. (-)	2820 Hz to 2550 Hz

NOTE: Tape Speed Measurement: PITCH CONT should be in OFF position. If necessary, adjust tape speed on the Capstan Servo P.C.B. See Fig. 7-7 below.

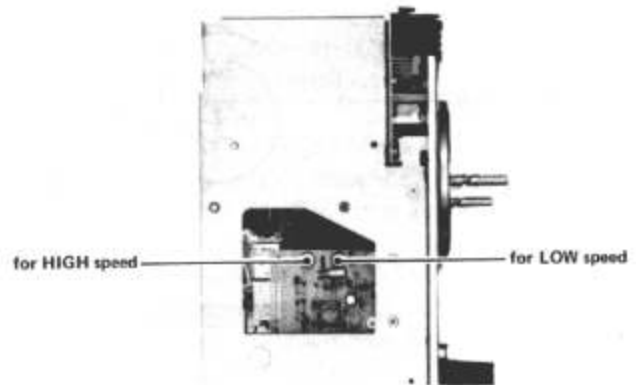

Fig. 7-7 Tape Speeds Adj. Location

7-7 LEFT TENSION ARM ADJ.

1. Place the deck in the Play mode.
2. Adjust the "ground terminal" (B) screw for uniform movement of the Tension Arm.
3. Adjust the "ground terminal" (A) so that when the tension arm is in the rest position, there is no gap between the "stopper" the side of the circular cut-out in which it sits. In other words, the lug should be adjusted so that the spring supplies just sufficient tension to hold the "stopper" against the side of the hole in the top panel. The "stopper" is the right-angled flange with a rubber sleeve labeled I in the illustration for section 4-3 (page 7).

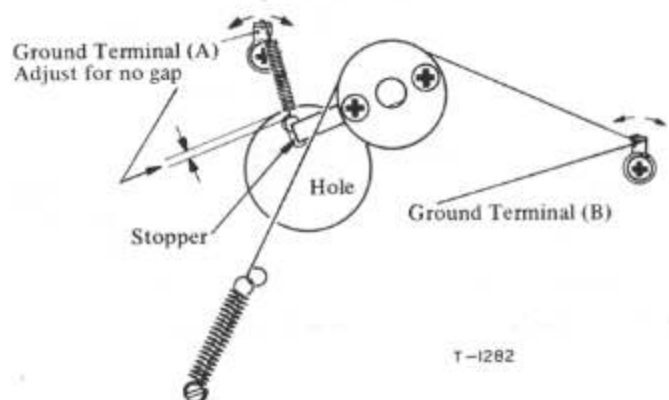

Fig. 7-6 Left Tension Arm Adj.

7-9 WOW AND FLUTTER CHECK

NOTE: Before performing this measurement, clean the head and tape run guides. Also check pinch roller pressure, etc. Use new test tape if possible for the following adjustments.

Values obtained with different standards or equipment cannot be compared.

PLAYBACK PERFORMANCE

1. Connect Test equipment to the deck as shown in Fig. 7-8. (Except Oscillator).
2. Load TEAC YTT-2003 (for LOW, 7½ ips) or YTT-2004 (for HIGH, 15 ips) tape, and playback.
3. Read the indication on the Wow and Flutter meter.
4. The Wow and Flutter should be:
 - 0.10% or less (WRMS) for 15 ips
 - 0.12% or less (WRMS) for 7½ ips

OVERALL PERFORMANCE

1. Connect test equipment to the deck as shown in Fig. 7-8.
2. Load TEAC YTT-8013 blank tape on the deck and Record a 3000 Hz input signal.
3. Rewind and playback the recorded signal.
4. The reading on the Meter should be:
 - 0.15% (RMS) for 15 ips
 - 0.18% (RMS) for 7½ ips

NOTE: These figures apply to any tape position (such as full take-up, full supply reel or about midpoint).

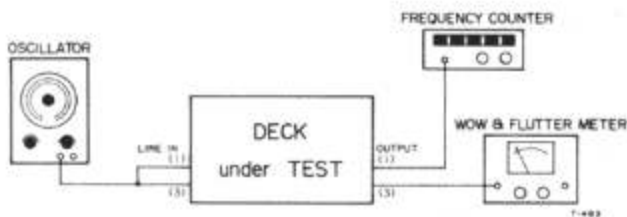

Fig 7-8 Test Connections for Wow/Flutter and Tape Speed Test

7-10 VOLTAGE AND FREQUENCY CONVERSION (GENERAL EXPORT MODEL ONLY)

This deck is adjusted to operate on an electric power source of the voltage and frequency specified on the reel tag and packing carton. If it is necessary to change the frequency or voltage requirements of this deck to match your area, use the following procedures.

ALWAYS DISCONNECT POWER LINE CORD BEFORE MAKING THESE CHANGES.

Frequency Conversion:

1. Remove the rear panel of the deck by removing 5 screws and 2 feet on the top.
2. Set the power frequency selector slide switch to the 50 or 60 position to match the power line frequency in your area. (See Location below.)

NOTE: This deck uses a DC Servo controlled capstan motor so it is not necessary to change the capstan drive belt.

Voltage Conversion:

The deck may be set for 100, 117, 220 or 240 volts. To alter the setting, pull out the voltage selector plug and reinsert it so that the desired voltage shows in the cutout. (See location below.)

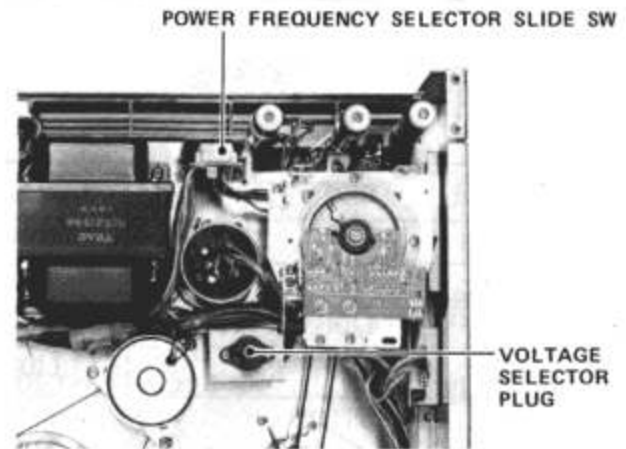
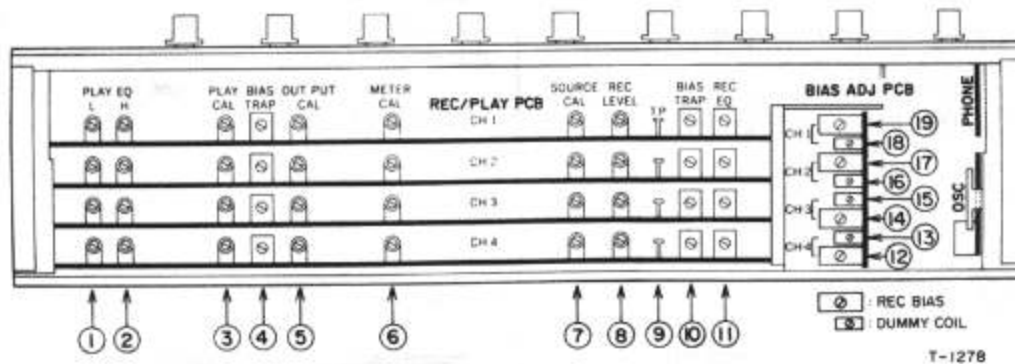

Fig. 7-9 Voltage and Frequency Conversion Locations

8. MEASUREMENT AND ADJUSTMENT — ELECTRICAL —

- Before performing maintenance on this deck, thoroughly clean and demagnetize the entire tape path. TEAC maintenance equipment to be used:
 TEAC TZ-261 A/B for cleaning
 TEAC E-3 or equivalent for demagnetizing
- Service Data were determined using TEAC YTT-Series Test Tape.
- The deck must be matched to the voltage and frequency of your locality.
 Refer to Power Requirement and Consumption chart (Item 2-1, Specifications Section).
- Most amplifier checks and adjustments can be made from the bottom with the (bottom) metal panel removed.
- Outlined procedures refer only to channel 1, the same procedures also apply to channel 2, 3 and 4.

ADJUSTMENT LOCATIONS AND ADJUSTMENT POINTS



①	R122	⑥	R159	⑪	L102	⑬	L382
②	R117	⑦	R194	⑫	C384	⑭	C382
③	R143	⑧	R206	⑬	L384	⑮	L381
④	L101	⑨	BIAS TRAP T.P.	⑭	C383	⑯	C381
⑤	R149	⑩	L103	⑮	L383		

Fig. 8-1 Adjustment Locations and Adjustment Points

8-MONITOR PERFORMANCE ADJ.-1

8-1 LINE INPUT LEVEL ADJUST

OUTPUT SELECT SW SOURCE
 INPUT SW LINE
 INPUT VR Maximum

1. Remove the special shorting connector joining ENCODER SEND and ENCODER RCV jack 1 (Channel 1).
 Connect a VTVM to the ENCODER SEND jack 1.

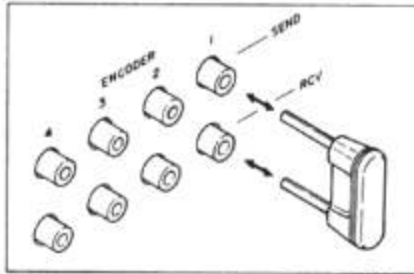

Fig. 8-2 Shorting Connector

2. Apply a 400 Hz -22 dB (61.5 mV) signal from an AF oscillator to LINE IN jack 1.
3. Adjust the SOURCE CAL. VR194 for -8 dB (308 mV) at ENCODER SEND jack 1.

NOTE: This is the Minimum Input Level

4. Change the input signal to -12 dB (195 mV).
5. Adjust INPUT level control for -8 dB (308 mV) at the ENCODER SEND jack 1.

NOTE: This setting represents the Specified Input Level

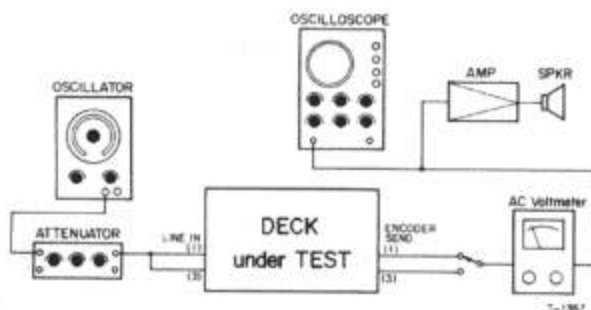

Fig. 8-3 Test Connections for Monitor Check

8-2 MIC CIRCUIT FUNCTION CHECK

INPUT SW MIC (ATT = 0 dB)

6. Apply a 400 Hz signal at -60 dB ± 2 dB ($975 \mu\text{V}$ – $615 \mu\text{V}$) to the MIC input jack (on front panel).
7. Check for -8 dB (308 mV) at ENCODER SEND jack 1.
 INPUT SW MIC (ATT = 20 dB)
8. Check for an output 20 dB ± 1 dB below the 308 mV output obtained in steps 6 and 7 above. (ie. Output should now be -28 dB or 30.8 mV)

8-3 OUTPUT AMP. GAIN ADJ.

9. Be sure the control are set as in 8-1 (Specified Input Level Setting).
10. Insert shorting connector between ENCODER SEND and RCV jacks.
11. Connect a VTVM to the OUTPUT jack 1.
12. Set the OUTPUT Level Control to position "8". This is the Specified Output Setting.
13. Apply a 400 Hz -12 dB (195 mV) signal from the oscillator to LINE IN jack 1.
14. Adjust OUTPUT CAL R149 for -8 dB (308 mV) at OUTPUT jack 1.

8-4 VU METER CALIBRATION

15. Adjust METER CAL R159 for 0 VU reading on the VU METER.

NOTE: Repeat the above procedures for channels 2, 3 and 4.

9-PLAYBACK PERFORMANCE ADJ.

9-1 PLAYBACK HEAD AZIMUTH ADJ.

NOTE: Before proceeding with the following head adjustments be sure that the heads have been properly mounted for HEIGHT, TILT and TANGENCY. See page 10.

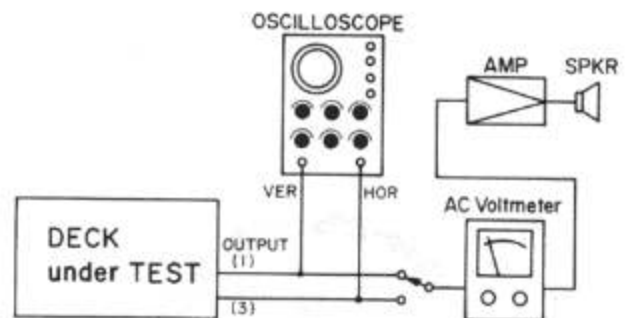

T-813

Fig. 8-4 Head Alignment Fine Adjustment Set-up and Test Connections (PLAYBACK)

OUTPUT SELECT SW PLAY

1. Connect a VTVM to the OUTPUT jack 1.
2. Remove the head housing by removing the 2 retaining screws.
3. Thread a TEAC YTT-1003 Test Tape on the deck.
4. Play (▶) the 16 kHz -10 dB test tone from section 2 of the test tape.
5. Slowly rotate the Azimuth screw until the maximum signal is read on the VTVM.
6. Connect an oscilloscope to the OUTPUT jack 1 and 3.
7. Adjust the Azimuth screw if necessary until the following phase difference figures are obtained.
 See next page.

Tape Speed	Frequency Limits	Phase Difference
7-1/2 ips.	400 Hz – 6 kHz	45° or less
15 ips.	400 Hz – 8 kHz	45° or less

NOTE: Phase difference readings are made between ch 1 and ch 3 and between ch 2 and ch 4.

8. After adjustment, secure the screw with a drop of locking paint.

9-2 OUTPUT LEVEL SETTING

9. The Specified Output Level Setting must be used.

See Item 8-3 step 12 above.

10. Connect a VTVM to the DECODER SEND jack 1.

11. Play the 400 Hz 0 dB tone in section 1 of the YTT-1003 Test Tape.

12. Adjust PLAY CAL R143 for -8 dB (308 mV) at DECODER SEND jack 1.

13. Insert shorting connector between DECODER SEND and RCV jacks.

14. Check for -8 dB (308 mV) at OUTPUT jack. (OUTPUT Level control at position "8").

MAX. OUTPUT LEVEL

15. Turn the OUTPUT Level control fully clockwise (max.) and check for -2 dB \pm 2 dB at OUTPUT jack 1.

16. Reduce OUTPUT Level Control until -8 dB (308 mV) is obtained on the VTVM.

NOTE: This is the Specified Output Level Setting. Do not disturb this setting until the remaining adjustments have been completed.

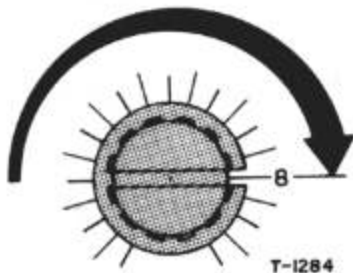

Fig. 8-5 Specified Output Level Setting

9-3 VU METER INDICATION CHECK

17. With the controls set as described above check that the VU METER reads 0 VU \pm 0.5 VU.

9-4 FREQUENCY RESPONSE – PLAYBACK

18. Play the Test Tape and compare the readings on the VTVM with the response limits given in Fig. 8-6.

Tape Speed	Test Tape	Play EQ Adj.
HIGH	YTT-1004	R117
LOW	YTT-1003	R122

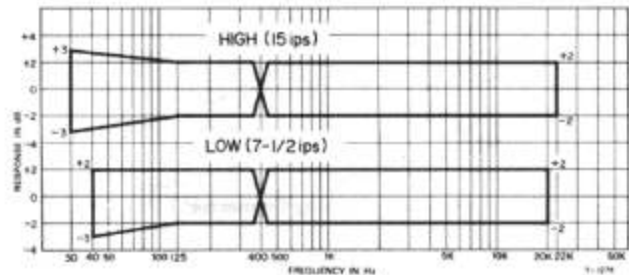

Fig. 8-6 Frequency Response –Playback–

NOTE: If the measured frequency response does not meet the specified response limits, especially at the high end of the spectrum, check that the heads are free of accumulated dirt or oxide. If they are completely clean the head azimuth must be readjusted.

9-5 SIGNAL-TO-NOISE RATIO – PLAYBACK –

19. OUTPUT Level Control should be at the Specified Output Level Setting.

20. Remove the Test Tape from the deck. Hold the shut-off arm (right) in the ON position.

21. Press the PLAY (▶) button.

22. The VTVM connected to the OUTPUT jack should indicate the values below.

OUTPUT SELECT SW	Tape Speed	S/N
PLAY	7-1/2 ips	-58 dB
	15 ips	-58 dB

NOTE: This corresponds to a signal-to-noise ratio of 50 dB (for PLAY 7½ ips). It is the difference between the residual noise of -58 dB and the specified output level of -8 dB.

10-MONITOR PERFORMANCE CHECK -2

10-1 MONITOR LEVEL CHECK

OUTPUT SELECT SW SOURCE
 INPUT SW LINE IN

1. Apply a 400 Hz -12 dB (195 mV) signal from the oscillator to the LINE IN jack 1.
2. Check for -8 dB (308 mV) at the OUTPUT jack. Also check for 0 VU on the VU METER.

10-2 HEADPHONE OUTPUT LEVEL CHECK

MONITOR CONTROL VOLUME . . . Maximum

NOTE: At this point both the INPUT control and the OUTPUT control are at their Specified Settings.

3. Connect a 4 ohm non-inductive resistor across the headphone (PHONES) jack and connect the VTVM across the resistor.
4. Depress the Headphone Selector Button for channel 1.
5. The VTVM should indicate -19 dB \pm 1 dB (77.5 mV - 97.5 mV).
6. Depress the buttons for channels 2, 3 and 4 so that all 4 are depressed.
7. The VTVM reading should increase to -6 dB \pm 2 dB (308 mV - 489 mV).

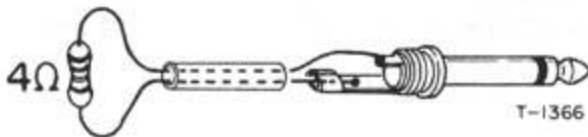

Fig. 8-7 Test Connections for Headphone Output Check

11-RECORD PERFORMANCE ADJ.

NOTE: For all record performance measurements and adjustments the FUNCTION SELECT SW should be ON for all channels.

11-1 BIAS TRAP ADJUSTMENT

1. Remove all Input Signals.
2. Thread a blank tape on the deck and depress RECORD and PAUSE buttons.
3. Connect a VTVM or oscilloscope to Test Point (T.P.) and ground. See Fig. 8-8.
4. Using a plastic trimmer tool, adjust the BIAS TRAP L103 for minimum reading on the scope or meter.

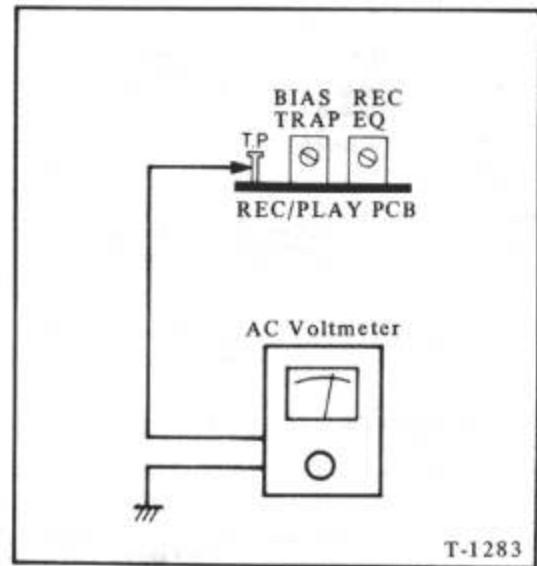

Fig. 8-8 Bias Limits Chart

11-2 RECORD BIAS ADJ.

Tape SPEED Selector SW . . . LOW (7-1/2 ips)
 OUTPUT SELECT SW PLAY

NOTE: Be sure the Bias Trap has been adjusted as per section 11-1.

5. Apply a 7 kHz signal at -22 dB (61.5 mV) to the LINE IN jack.
6. Turn the trimmer capacitor C381 fully counter-clockwise.
7. While recording on the YTT-8013 blank tape, slowly turn the Trimmer Capacitor clockwise until the reading peaks and continue turning clockwise until the reading backs off 2 dB.
8. These procedures are repeated for channels 2, 3 and 4.

NOTE: The Trimmer Capacitors are located on the BIAS P.C.B. Refer to page 16 Adj. Location and Adj. points.

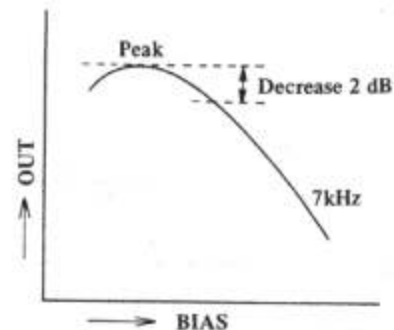

T-712

Fig. 8-9 Bias Limits Chart

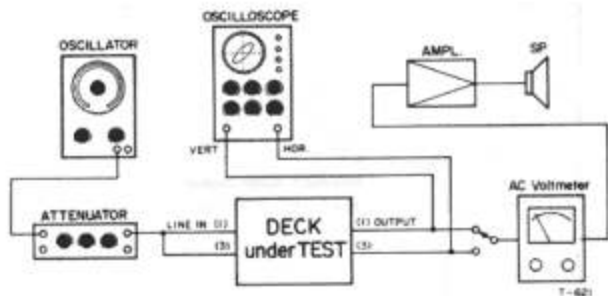

Fig. 8-10 Test Connection for Recording Check

11-3 RECORD LEVEL SET

9. Apply a 400 Hz signal at -12 dB (195 mV) to the LINE IN jack.
10. Check that the LINE and OUTPUT Controls are still at their specified positions.
11. Begin recording.
12. Adjust REC LEVEL R206 for -8 dB (308 mV) at the OUTPUT jack.

11-4 FREQUENCY RESPONSE – OVERALL

NOTE: To avoid saturation of the tape these checks should be made at least 10 dB (-10 VU) below the specified input level (ie. -22 dB/61.5 mV) for LOW Speed and at 0 VU for HIGH Speed.

Any bias signal feeding into the test equipment should be filtered out by adjusting the external bias trap.

Tape SPEED Selector SW LOW

1. Apply a signal swept from 40 Hz to 20 kHz at -22 dB (61.5 mV) to the LINE IN jack and record on a blank TEAC YTT-8013 tape.
2. During recording monitor the off-tape signal and adjust Equalization REC EQ L102 for readings within the response limits.

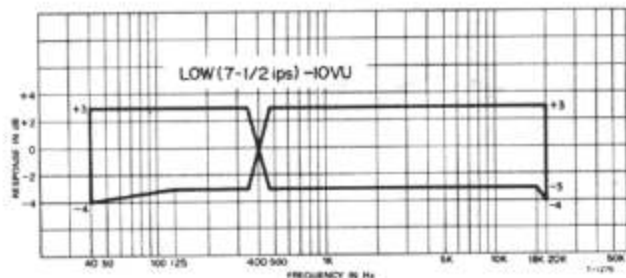

Fig. 8-11 Frequency Response –Overall– 1

Tape SPEED Selector SW HIGH

3. Apply a signal swept from 40 Hz to 22 kHz, this time at a level of -12 dB (195 mV) and check that the response is within the limits indicated.
4. If REC EQ L102 are adjusted check LOW section again.

NOTE: If the response is not uniform, the heads should be checked for accumulated dirt and oxide and the bias adjustment should be repeated.

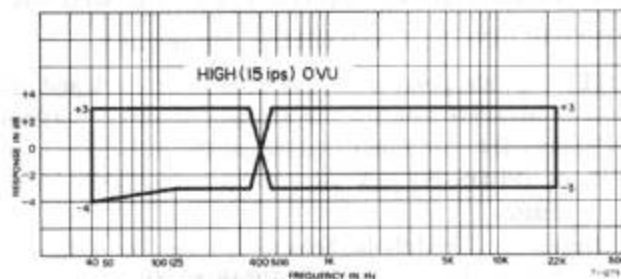

Fig. 8-12 Frequency Response –Overall– 2

11-5 SIGNAL-TO-NOISE RATIO – OVERALL

5. OUTPUT and LINE Controls should be at the specified positions.
6. Remove the AF oscillator from the LINE IN jack.
7. Place the deck in the Record mode with no signal applied.
8. Note the point on the Index Counter where the recording begins.
9. Rewind the recorded tape to the beginning and play it back.
10. The noise levels read on the VTVM should be as follows:

Tape Speed	Noise Level
LOW (7-1/2 ips)	-54 dB (1.55 mV) or better
HIGH (15 ips)	-53 dB (1.73 mV) or better

NOTE: This -53 dB/ -54 dB corresponds to a S/N ratio of 45 dB/46 dB (minimum), being the difference between the residual noise and the specified output level of -8 dB.

The measuring method used to establish the S/N spec. in the catalogue and the owner's manual is different and these figures will not be the same.

11-6 OPTIMUM ERASURE MEASUREMENT

Tape SPEED SELECTOR SW . HIGH (15 ips)

1. Thread the YTT-8013 test tape on the deck.
2. Apply a 1 kHz signal at 10 dB above the specified level of -12 dB (195 mV) to LINE IN jack 1.
3. Make a 30 second recording of the above signal and rewind to the beginning of the recording.
4. Disconnect the 1 kHz signal source from the LINE IN jack.
5. Connect a VTVM to the OUTPUT jack 1 through a 1 kHz Narrow Band Pass Filter.
6. Set the OUTPUT SELECT SW to PLAY position.
7. Put deck in the RECORD mode and "record" (erase) over this previous recording, then rewind to beginning again.
8. Put deck in PLAY mode and monitor the Channel 1 output on the VTVM.
9. The difference in output level compared with the above recording level should be more than 65 dB.
10. Repeat this procedure for the other channels.

NOTE: Do not overlook filter loss when making this measurement.

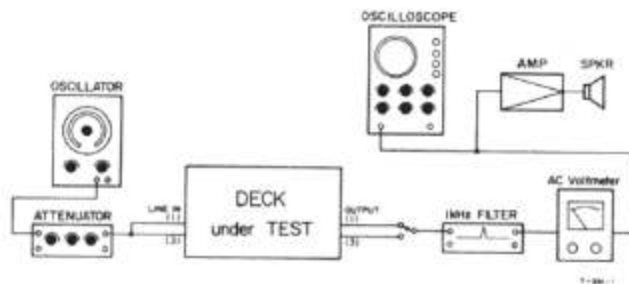

Fig. 8-13 Test Connections for Erase Measurement

11-7 CHANNEL SEPARATION

OUTPUT SELECT SW PLAY

TAPE SPEED SELECTOR SW HIGH (15 ips)

FUNCTION SELECT SW all ON

NOTE: Be sure that the Line and Level controls are still at their specified positions.

1. Apply a 1 kHz signal at -8 dB (308 mV) to channels 2, 3 and 4.
2. Place deck in the Record mode.
3. While recording measure the output from channel 1 with a VTVM connected through a 1 kHz bandpass filter. The level should be -48 dB or better. (Spec. 40 dB)
4. Depress the STOP button.

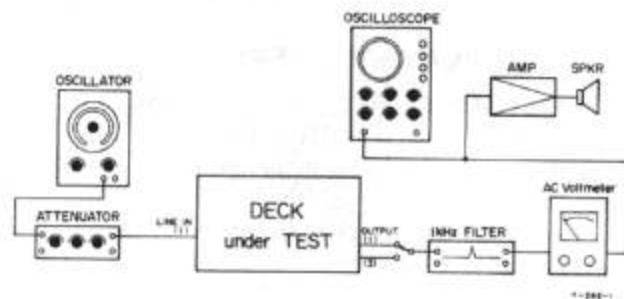

Fig. 8-14 Test Connections for Channel Separation Check

11-8 BIAS LEAKAGE CHECK

OUTPUT Level Control Maximum

6. Remove the Head Housing. Connect a VTVM to the OUTPUT jack.
7. Place the OUTPUT SELECT SW to PLAY position.
8. Put the deck in the Record mode.
9. Adjust TRAP L101 for minimum bias leakage reading at the OUTPUT jack. Reading should be -48 dB or less with the OUTPUT SELECT SW in any position.

11-9 DISTORTION CHECK

1. Thread the YTT-8013 test tape on the deck.
2. Apply a 1 kHz signal to the LINE IN jack at 0 VU.
3. With the Line and Output Level Controls set to the specified position, place the deck in the record mode for approx. 30 seconds.
4. Rewind and play this recorded section of the tape.
5. The distortion read on the distortion analyzer should be 1.0%, or less.

12-SIMUL-SYNC PERFORMANCE

12-1 SYNC PLAYBACK LEVEL

OUTPUT SELECT SW SYNC

1. Connect a VTVM to the OUTPUT jack.
2. Play the 400 Hz 0 dB tone in section 1 of the YTT-1003 Test Tape.
3. Check for $-8 \text{ dB} \pm 1 \text{ dB}$ ($356 \text{ mV} - 275 \text{ mV}$) at the OUTPUT jack.

12-2 SYNC FREQUENCY RESPONSE — PLAYBACK—

4. Apply a signal swept from 50 Hz to 6.3 kHz at -12 dB (195 mV) and while monitoring the off-tape signal check for readings within the Response Limits.

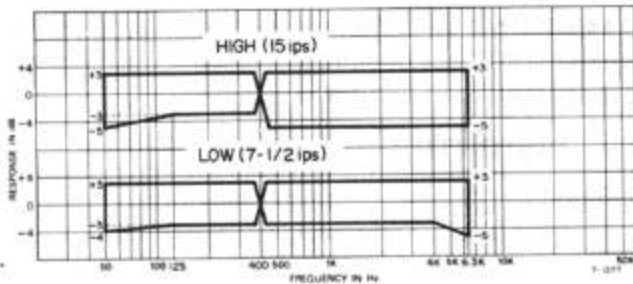

Fig. 8-15 SYNC Freq. Response

12-3 SYNC S/N RATIO CHECK

1. OUTPUT Level Control should be at the Specified Output Level Setting.
2. Remove the Test Tape from the deck. Hold the shut-off arm (right) in the ON position.
3. Press the PLAY (▶) button.
4. The VTVM connected to the OUTPUT jack should indicate the values below.

OUTPUT SELECT SW	Tape Speed	S/N
SYNC	7-1/2 ips	-48 dB
	15 ips	-48 dB

NOTE: This corresponds to a signal-to-noise ratio of 40 dB (for SYNC 7-1/2 ips). It is the difference between the residual noise of -48 dB and the specified output level -8 dB .

12-4 SYNC CHANNEL SEPARATION

TAPE SPEED SELECTOR SW HIGH (15 ips)
FUNCTION SELECT SW all ON

1. Repeat the page 21, item 11-7 procedure and check the crosstalk in the SYNC mode. The level should be -53 dB or better (spec. 45 dB).

12-5 SYNC CROSSTALK CHECK

1. Apply a 2 kHz -12 dB (194 mV) signal from the AF oscillator to the LINE IN jacks 1,3 and 4.
2. Place the deck in the REC and PAUSE mode.
3. Ensure that the FUNCTION SELECT SW for channel 2 is OFF.
4. Check the difference in level between the Sync output (1,3 and 4) and (2).
The difference should be 8 dB or less.
5. Repeat these procedures for channels (1,2 and 4) and between 3.

9. SERVICING AND MAINTENANCE

9-1 CLEANING

TEAC TZ-261A for Head cleaning and TZ-261B for Rubber cleaning should be used. Use as follows:

TZ-216A	TZ-261
Motor pulley	Pinch roller rubber
Heads, Brake drums	Capstan belt
Capstan shaft	Counter belt
Tape run guides	

9-2 LUBRICATION

Under normal operating conditions, lubrication is required only once each year. Before lubricating, clean the drive belt and drive pulley... etc. Operate the deck for 30 minutes to 1 hour immediately prior to oiling. After oiling, keep the deck in the upright position for 3 to 4 hours to allow thorough absorption of the oil.

Approximately once each year or after 2000 hours of use, apply TEAC TZ-255 or equiv. Lubricating Oil to the following places only;

- Pinch roller shaft 1 drop
- Capstan shaft 2 drops

(Remove the dust cap for access to the oil pit)

NOTE: Excessive oiling will scatter oil inside the deck. This oil will cause drive belt slippage and other difficulties. Check for slippage and clean all parts inside the deck before operating after lubrication. Check for oil emission after operation and before returning deck to the customer.

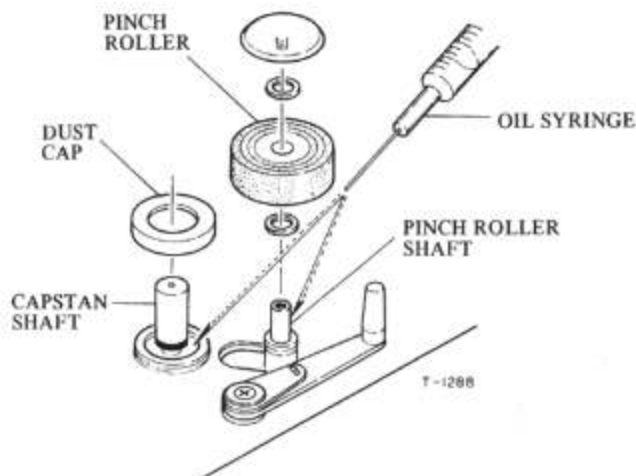

Fig. 9-1 Capstan Shaft and Pinch Roller Shaft Oiling Points

9-3 TEAC MAINTENANCE FLUIDS



Fig. 9-2 TZ-255 Oil Kit



Fig. 9-3 TZ-261 Tape Recorder Kit

9-4 DEMAGNETIZATION OF HEADS

If the Record or Playback heads become magnetized, noise will increase and tonal fidelity will deteriorate. For this reason it is advisable to use non-magnetic tools when working near the heads. If the heads have had any contact with current or magnetized metal parts, demagnetize them with a TEAC E-3 eraser or equivalent.



Fig. 9-4 TEAC E-3

10. SIMPLIFIED SCHEMATIC AND LEVEL DIAGRAMS

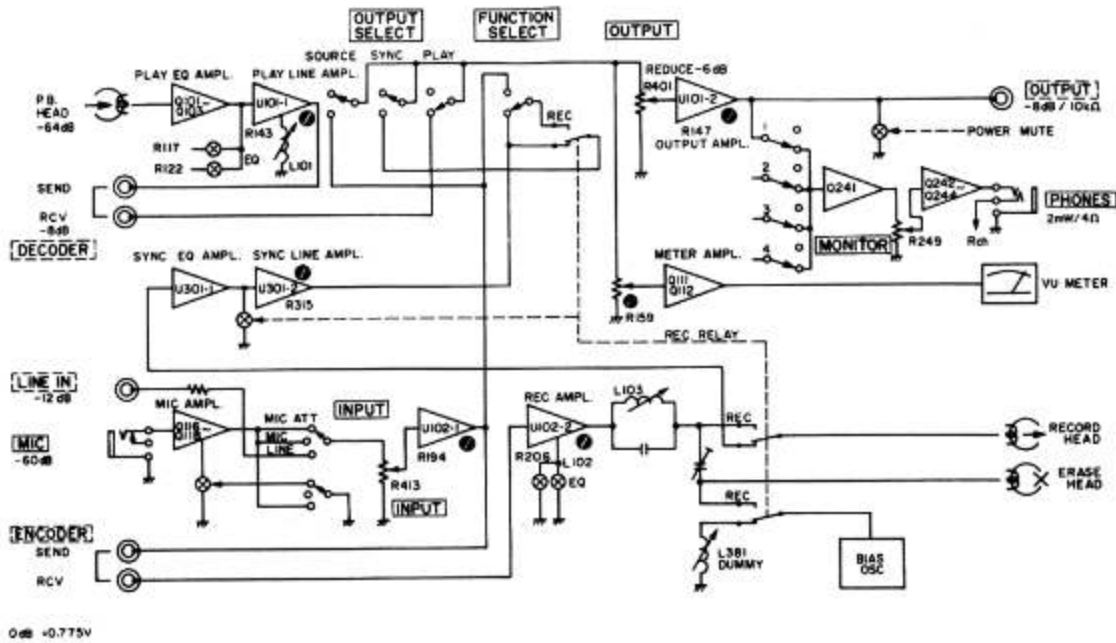
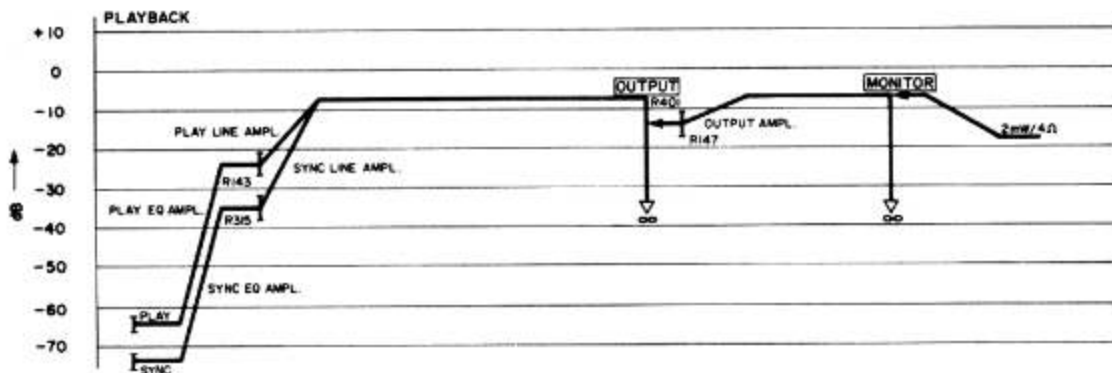
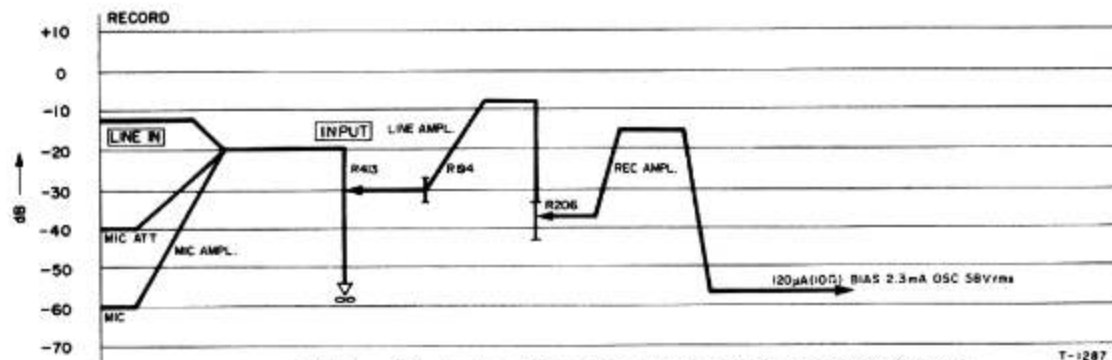

Fig. 10-1 Simplified Schematic Diagram

PLAYBACK



RECORD



NOTE: — Playback and Record Controls are Positioned at specified level.
 — Each level given in the diagram shows values when 400 Hz specified level is applied.
 — 0 dB = 0.775 V
 — Ref. Nos. shown in the diagram relate only to the left channel.

Fig. 10-2 Level Diagrams

A-3440

4-Channel Multitrack Tape Deck with SIMUL-SYNC

TEAC

TEAC CORPORATION

3-7-3 NAKA-CHO MUSASHINO TOKYO PHONE (0422) 53-1111

TEAC CORPORATION OF AMERICA

7733 TELEGRAPH ROAD MONTEBELLO CALIFORNIA 90640 PHONE (213) 726-0303

TEAC AUSTRALIA PTY., LTD.

115 WHITEMAN STREET SOUTH MELBOURNE VICTORIA 3205 PHONE 699-6000

PRINTED IN JAPAN 0684 SYUO 5 D-2927G
