

Return to PSS

May 1st 1963

NAGRA

INSTRUCTIONS MANUAL

KUDELSKI

6, ch. de l'Etang, Paudex - Lausanne, Switzerland

Office-hours
Phone
Telex

7.30 - 12.00 a. m. and 1.30 - 6.00 p. m. (saturday closed)
Lausanne (021) 26 62 62
Switzerland 24 302

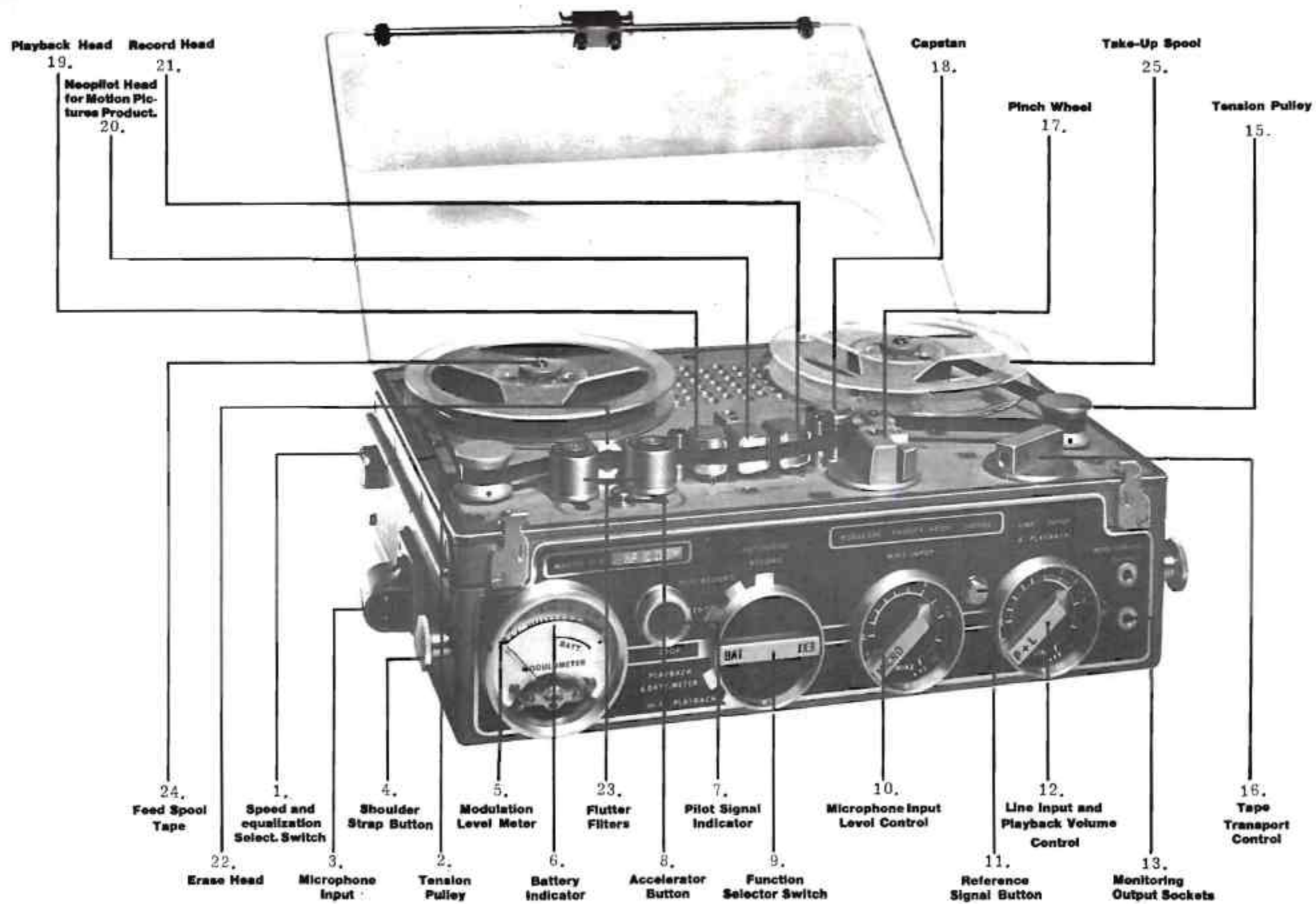

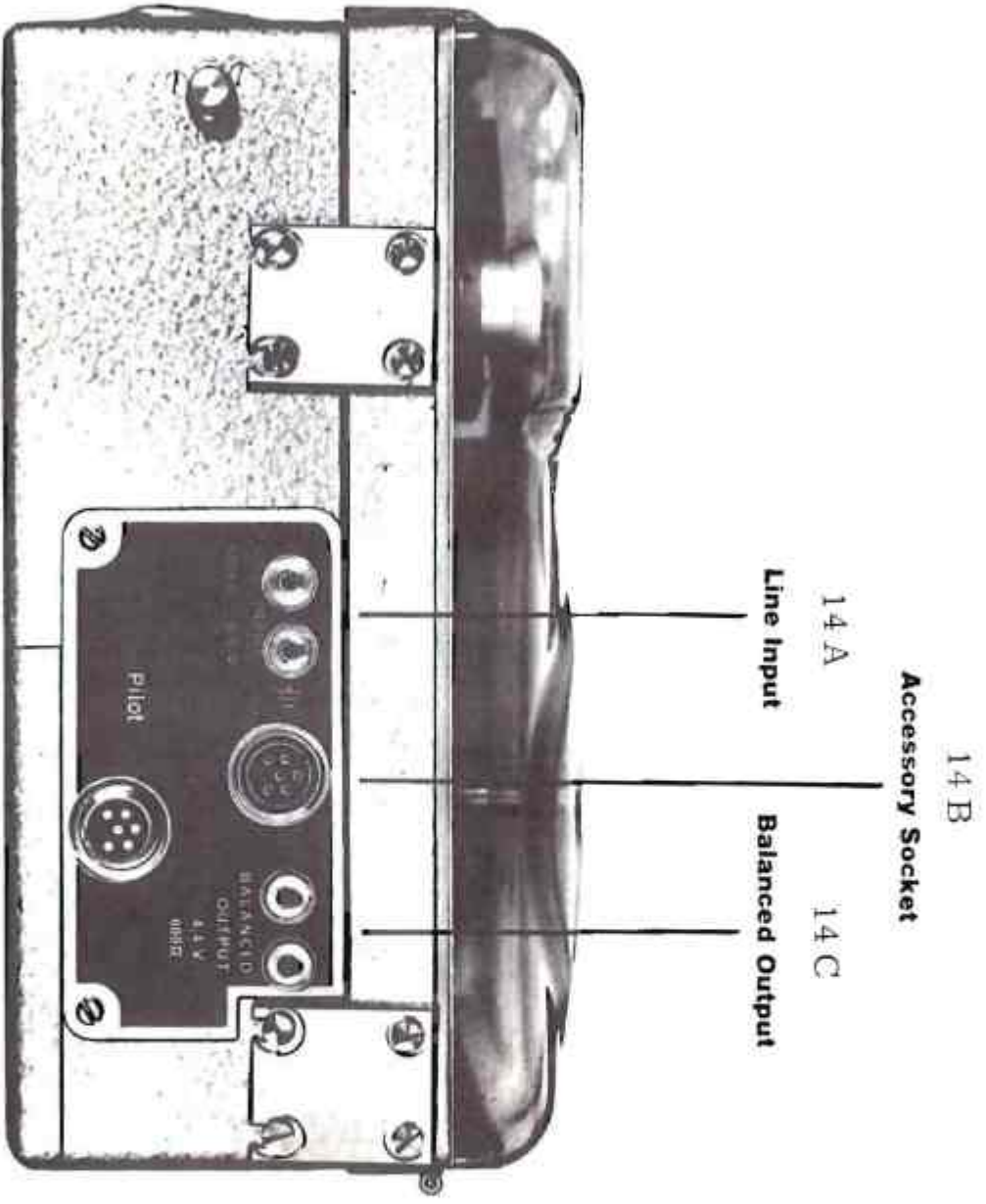

NAGRA III TAPE RECORDER

INSTRUCTIONS FOR USE

I. PRECAUTIONS TO BE TAKEN

- When out of use, turn the tape transport control to its mid position. In the "ON" position, when not running, there is danger of producing a flat on the capstan roller. The working surfaces of the fast rewind clutch may also suffer.

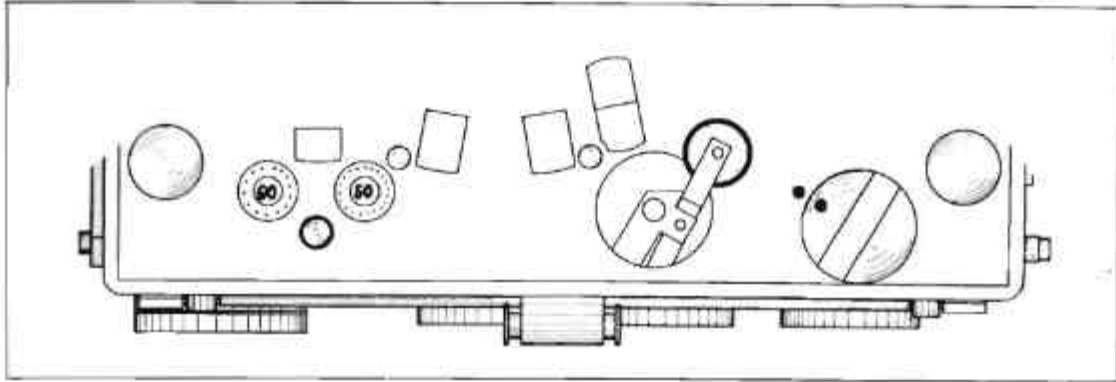

- When batteries are exhausted, a corrosive liquid may escape and the containers may corrode. Never leave discharged batteries in the Nagra. If the machine will not be used for sometime (a few months), remove the batteries, even if they are not discharged, as a precaution.
- Take care that the batteries are inserted into the machine with correct polarity. Place them in the battery compartment as indicated by the small diagram on the bottom of the compartment. When an external power supply is used, always check the polarity very carefully. If it is incorrect, the motor will run backwards. A special protective circuit is used to prevent damage to important parts of the Nagra, but even so it is possible that some electrolytic condensers could be damaged.
- The Nagra III is very robust, but it is better to take no chance. Protect it from sand, sea, being dropped, or from mechanical shock. Do not subject it to rapid changes of temperature, or to the curiosity of unqualified personnel, and above all, from vibration. For instance, do not carry it unprotected in the baggage compartment of a car.

II. DESCRIPTION OF CONTROLS AND EXTERNAL MECHANISM

1. Speed and Equalization Selector.

This switch may be operated by a coin in the slot. It simultaneously changes speed and equalization, both for recording and play-back. The following combinations are available:

38,1 cm/sec. = 15"/sec. (CCIR or Ampex)

This speed is normally used in broadcasting studios. The use of it, insured the best quality; the azimuth adjustment is not very critical, while the response

curve is always excellent and varies little from tape to tape. At this speed the tape is little affected by repeated play-backs. Another advantage is that editing is easy, and that a suitable machine operating at this speed can usually be found in studios for play-back of recordings.

19,05 cm/sec. = 7.5"/sec. CCIR Equalization Standard

This is the normal speed for the general uses of the Nagra in studios working with the CCIR standards. Where this is not necessary, the following position will be preferred:

19,05 cm/sec. = 7.5"/sec. Ampex Equalization Standard

This is a better standard, as the modulation noise, medium range distortions and tape background noise are reduced considerably.

9,525 cm/sec. = 3.75"/sec.

This speed is for use where high quality is not required and tape economy is important. One hour recording time can be obtained with the use of 5" reels and using extra thin tape or two hours with 7" reels.

2) Tension Pulley

This pulley is movable and operates a brake on the spool, ensuring constant tape tension.

3) Microphone Input

The microphone should have an impedance of 50 or 200 ohms. This input socket on the Nagra is Cannon type XLR 3-42. The plug on the microphone cable is Cannon type XLR 3-11C. Contact No. 1 is earth and 2 and 3 are the microphone connections. The input is symmetrical and floating, there being no connection between primary and earth.

4) Shoulder Strap Button

For the attachment of a shoulder strap or ever ready case a small set screw is fitted for safety in the nut (3 mm. Set screw, for Allen key to DIN 913: a key 0.050" (1.27 mm) is provided).

5) Modulation Level Meter

The upper scale on the meter is for measuring the input level (on Test or on Record), and the output level to the line on Hi-Fi play-back. Normally the pointer will not reach the black segment between 0 and +2db, which is the region of over modulation. The recorder has a safety factor of about 6 db, so that an occasional accidental incursion into this region is of no consequence. The level control should be adjusted so that the pointer only reaches the black zone on the loudest parts of the recording.

6) Battery Indicator

The lower scale of the meter is for checking the state of the batteries. The meter is connected to the batteries when the selector switch indicates "Play-back and Batteries Meter", that is, when playing back on the internal loud-speaker. The pointer should lie in the marked segment when the batteries are in working condition. This indication leaves a good factor of safety when

employing this speed, headphones should be used for monitoring. Then when the battery voltage falls to a level unsatisfactory for recording an alarm signal will be heard in the phones. It is well to remember that batteries used uninterruptedly for, say, an hour, will recuperate when rested for, say, 10 hours. Therefore exhausted batteries may appear acceptable during a quick test before recording, but then collapse after a few minutes use.

To recapitulate:

- If one is recording at 15"/sec. always use monitoring headphones and read the battery meter pessimistically.
- If one is recording at 7 1/2" or 3 3/4"/sec. for fairly short periods, say 15 minutes, a battery test before starting should be sufficient. On the other hand, if the recording session is of long duration, the batteries should be checked when changing reels.

7) Pilot Signal Indicator

This is an indicator on which a white cross will appear when the Nagra is receiving the pilot signal (Neopilot Nagras only).

8) Accelerator Button

By pressing this button the motor speed is increased to its maximum. This can be done during play-back for forward spooling. Although no damage will be done by pressing the button during recording, the speed will be incorrect.

9) Function Selector Switch

This switch controls the functioning of the Nagra. It has two sets of six positions. One set is for working on internal batteries when the end of the switch knob marked "bat" is used as an indicator, and one set is for working with an external power supply, when the other end of the knob, marked "ext", is used as an indicator.

The positions are as follows:

STOP	in the centre
TESTING	to the right

In this position the amplifiers are connected but not the motor, so that the incoming signal to be recorded can be checked. The monitoring phones are connected to the record amplifier.

HI-FI RECORD = Normal recording position.

The phones are connected to the play-back amplifier, so that the actual recording that has been made is monitored. Incoming signals can be mixed from both microphone and line inputs. The level of each of these signals can be adjusted by the appropriate volume controls. If the line input is only used, the microphone level potentiometer should be turned fully anticlockwise to prevent the recording of noise from the microphone pre-amplifier. On the other hand, if a recording is made through the microphone channel only, the position of the line input volume control is immaterial.

AUTOMATIC RECORD = Recording with automatic control of level and attenuation of low frequencies. It is not necessary to adjust the level potentiometer but the quality of the recording is not as good as in the position HI-FI RECORD.

The automatic record position is useable for speech but not for music. The automatic facility only affects the microphone channel and not the line input.

PLAYBACK & BATT. METER to the left = Play-back on the internal loudspeaker. In this position the meter indicates the battery voltage. The play-back level is varied by the "line input and playback" volume control. The headphones are fed directly from the play-back amplifier at an uncontrolled level. The quality through the loudspeaker or at the line output is not high. On the other hand the monitoring output for headphones is always fed with a high quality signal.

HI-FI PLAYBACK = Normal high quality play-back.

The loudspeaker is out of circuit and the signal output is fed at low level for headphones at the monitoring output and at high level to the line output sockets. The signal fed into the line is measured by the meter. This output consists not only of the signal play-back from the tape and adjusted by the control "line input and play-back" but also a signal from the microphone can be added for a commentary. The level of this signal is controlled by the mike input potentiometer. When this facility is not required the mike input potentiometer must be turned fully anticlockwise when replaying a normally recorded tape. To play back a normally recorded tape, the "line input and play-back" control should be turned to the indication 0 db. This will produce a normal signal to the line. If it is necessary to vary this control to have a normal signal to the line, it is an indication that the recording has not been made at normal level. This is a useful facility for checking a recording.

10) Microphone Input Level Control

This control varies the modulation level of the signal, which is fed into the microphone input.

11) Zero Level Reference Signal Push Button

This push button, sends a whistle through the line input while the recorder is running. It is useful to record this whistle before recording sound at a zero level, that is to say, the modulometer needle should point to zero on the scale. This signal is highly useful for the regulation of the chain of sound transfer. It is as well to leave at least two complete turns of the tape between the signal and the sound track so as to avoid the possibility that it might be superimposed on the sound track during the transfer process.

12) Line Input and Play-back Volume Control

This control has two purposes:

- a) During Hi-Fi recording it varies the modulation level of the signal fed into line input.
- b) During play-back it varies the signal output.

13) Monitoring Output Sockets

These sockets are suitable for headphones, with an optimum impedance of 50 ohms. Any other impedance value will only result in a reduced level. It is preferable to use electrodynamic headphones of high quality. In operation this output is taken from:

- The recording amplifier when on "Testing"
- The play-back amplifier on "Record" "Automatic Record" and "Play-back and Batt. Meter".
- The line amplifier on "Hi-Fi Play-back"

The normal output level is approximately 250 mV. One can use this output to connect the Nagra to an external power amplifier.

Alarm Signal. This signal is injected between the lower socket of the monitoring output and earth, when the motor speed stabiliser reaches the bottom of its range, that is, during fast rewind and in case of exhaustion of batteries or accidental braking of the motor. If one uses this output for connection to a power amplifier, the alarm signal can be quite annoying. In order to avoid this, one connects the external amplifier between the earth on the line input on the right side of the apparatus, and the upper socket of the monitoring output.

14) a. Line Input

This input is at high impedance and one can connect it, for instance, to a radio receiver to record a transmission. The input impedance is 100.000 ohms and the normal level 0,5 volt.

b. Accessory Socket

The corresponding plug is a Tuchel T. 3400. The connections are shown on the surrounding label as follows:

1. o Batteries = taken direct to the negative of the internal battery. This can be used for recharging internal accumulators if they are employed in place of batteries.
2. o Earth = the positive of the battery is connected to earth.
3. o Line = This line input is similar to the line input mentioned above but the impedance is 2500 ohms and the normal level 8 mV. This is for use with the Nagra accessories such as external microphone preamplifier.
4. o Stop = connection for remote control - if reconnected to earth the motor will stop.
5. o External = This is the connection for the negative of an external power supply. The applied voltage should be between 12 and 24 volts DC and must not exceed 25 volts.
6. o - 10.5 V = regulated voltage for supply of accessories.

c) Balanced Output

This line output is symmetrical and floating. The characteristics are marked on the label:

with a load not less than	600 ohms	4,4 V (+ 15 db) or
" " " " "	100 ohms	1,55 V (+ 6 db)

a At this socket the following signals will be found:

- During testing and recording, the signal applied to the recording head. One should not load these sockets during this operation. (Except when a DH amplifier is used).
- During Play-back & Batt. Meter the signal feeding the with reduced reserve of the level.

- Do not use this position for high quality feed to another unit.

- During Hi-Fi Play-back these sockets carry the normal line output signal.

15) Tension Pulley

This pulley is movable and controls the take-up spool clutch. The normal tape tensions are given in the specification of the instrument.

16) Tape Transport Control

Turning this control which is marked on one side "En-On" clockwise, brings the pinch wheel into contact with the capstan. Turning it to the left disengages it, and starts rapid tape rewinding. This occurs when the selector switch (No. 9) is turned to either play-back position, rewinding does not take place when the switch is on "record", to diminish the possibility of mistakes. If re-spooling is required when the switch is at "Testing" this can be obtained by depressing the accelerator button (No. 8). When the equipment is not in use, this control must be left in the mid position. (See page 1).

17) Pinch Wheel

This rubber roller presses the tape against the capstan to drive the tape. It is operated by the control mentioned above (No. 16) The pressure of the pinch wheel can be adjusted by means of a screw on the assembly. (1 kg optimal).

18) Capstan

This drives the tape at a constant speed.

19) Play-back Head

20) Neopilot Head

21) Record Head

22) Erase Head

23) Flutter Filters

These carry markings which enable the tape speed to be checked stroboscopically. When lightened by a pulsed light source (e. g. from an electric lamp, preferably fluorescent, supplied from 50 or 60 c. p. s. mains) they give the impression of being stationary, if the tape speed is exactly correct. On the other hand, if the dots appear to turn slowly clockwise, the speed is too great, and conversely. The number engraved on the top of the guide gives the mains frequency for the correct speed. To appreciate the magnitude of error of speed, at 50 c. p. s. a movement of one dot over a distance equal to the separation between dots in one second indicates an error of 1%. If the time taken is ten seconds, the error is 0,1%. It must be taken in account that the mains stability

is not perfect. Variations of 0,5% are quite common. The speeds are set at the factory by comparison with a standard generator driven from a Quartz crystal clock. Therefore the speed should not be readjusted if the mains frequency is not known to be accurate.

24) Feed Spool

The tape to be recorded or reproduced is placed on this spool, with the coating (matte surface) wound inwards.

25) Take Up Spool

The Battery Box compartment is accessible from the bottom of the instrument. A normal set of batteries consists of 12 1.5 volt torch cells. When changing cells, all should be changed together, as one inferior cell will subtract from the performance of the good ones.

It is very important not to make any mistake over the polarity of the batteries, all should be turned in the same direction as indicated by the diagram on the bottom of the box. It is more convenient to put the end cells in place first, and then the centre cells. The minimum voltage below which a cell cannot be used is 0.9 volt.

Usable battery types are:

- 1) Alkaline cells such as ever-ready E95 (life about 70 hours).
- 2) Ordinary torch dry cells, (diam. 33 mm, length 60 mm) (life about 10 to 20 hours).

U.S.A.	Ever-ready 950 D, R. C. A. VS. 036 Ray-O-Vac 2 LP, Burgess 2D, Usalite 879
England	Vidor V 0002, Berec U 2
Germany	Titania 2211
France	Wonder "Marin" 1602, Mazda (Cipel) RGT 1,5V
Spain	Hellesens 211
Switzerland	Leclanché 300 ou 300 S
Pakistan	Alladin 1,5 V cell
India	Ever-ready 1 F 3
China	Pile Elephant 1,5 V
Hongkong	Kai-it 360
Italy	Super Pila No. 60

It is desirable to use the steel clad type of cell, with silvered contacts, to avoid trouble due to corrosion and bad contacts.

3) Sealed Accumulators. These are rechargeable. It is often possible to recharge these 400 times, although the manufacturer does not guarantee more than 100 rechargings. They have the disadvantage of a very constant output voltage so that it is very difficult to estimate the amount of charge remaining. Their capacity is comparable to that of ordinary cells, but they are heavier, increasing the total weight of the Nagra by about 1 lb. 3 ozs.

Switzerland	Leclanché 32 A
Germany	DEAC 2,5 Ah
U.S.A.	Gould 2,5 Ah

THE SPEED STABILISER

The Nagra III uses a new technique for controlling the speed of the motor and the following notes will be helpful to those who need to service the machine.

I. Description

The block diagram herewith illustrates the principle of the servo-circuit which is used. The motor carries on its spindle a phonic wheel as well as the capstan, which passes in front of a magnetic head - the tachometer head. This head is magnetised and the rotation of the phonic wheel induces an alternating current, the frequency of which depends upon the speed of rotation of the motor. This signal passes through the tachometer amplifier where it is shaped into a square wave of constant amplitude of about 6 volts peak to peak. This output is taken to a frequency discriminator. This operates the servo amplifier which controls the motor speed. As the voltage at the servo amplifier becomes increasingly negative, so the motor current will increase.

The circuit described is not self-starting. Therefore the Nagra includes a starter which applies to the servo amplifier a large negative voltage when one switches to "play-back" from "stop" or from "test" to "record", and also when the connection between the socket "stop" on 14b and earth is opened. This applied voltage causes the motor to start rapidly.

The system could function just in this way, the discriminator being sufficiently powerful to intercept and take the motor under control as the speed passes into the range of the discriminator. However, the speed would not be correct immediately. It would be above normal for several seconds, that is, for the time necessary for the starting condenser to discharge. To overcome this difficulty a special transistor discharges the condenser when the circuit of the discriminator begins to resonate. This gives excellent starting. At all times a precaution must still be taken, the signal coming from the tachometer amplifier is a square wave, that is, it contains about 30% of third harmonic.

Put another way, during the passage at $1/5$ and above all at $1/3$ of the speed, the circuit of the discriminator could resonate and the starting condenser will be discharged. We inserted a threshold diode, visible on the diagram, to avoid any discharge for a signal of less than 50%.

Notice that the accelerator button works directly on the motor while the rapid rewind works through the servo amplifier. This can help in localizing a fault. Remember that the rewind circuit is disconnected when the selector switch is on "record".

II. Possible Difficulties:

1) Faults in starting

- a) The motor refuses to run even after pressing the accelerator button or starting it by hand. Check the tension of the brushes and examine the commutator.

- b) The motor starts occasionally but not always, or on turning by hand. The commutator may be dirty, clean it but do not lubricate it.
- c) The motor starts after pressing accelerator button and comes up to speed, but does not start on its own. Fault in starter. Measure the voltage across the starting condenser.
- d) The motor starts well, passes the normal speed and then loses speed and stops. This is a typical case where the servo amplifier and the starter are functioning, but the discriminator or the tachometer head is not working. Start the motor with the accelerator button with a driving voltage of 10 to 15 volts. The tachometer head should develop more than 8 millivolts. If the head is in good condition inject a signal of 3 millivolts from a low frequency source corresponding to the speed of working. This will permit tracing the signal through the tachometer amplifier.

In case of trouble of this sort it is good to try straight away whether operation is satisfactory on other speeds. It is at $3\frac{3}{4}$ " per second that one has most difficulty because of a weak tachometer signal. If operation is satisfactory at $3\frac{3}{4}$ ", but not at any other speed, examine carefully the wires joining the speed switch to the speed regulating inductances etc.

- e) The motor starts but does not reach normal speed. Disconnect the collector of the transistor T. 4 which discharges the starter condenser and so ascertain whether this transistor is discharging the condenser too soon or whether the charge on the condenser is too small, that is to say, whether the motor is too difficult to start. One can then determine whether the motor is half open circuit and needs too much voltage or if the supply is incapable of producing the necessary voltage or whether there is untoward mechanical friction or a faulty servo amplifier. On replacing the motor by a milliammeter, there would be a starting current of at least 400 milliamps flowing, for more than one second. Measure the voltage across the last transistor in the servo amplifier. If all the applied voltage reaches the motor, without being able to reach its full speed conclusion obvious. On the other hand, if the disconnection of the discharging transistor T. 4 makes starting possible, check whether the stand off voltage is accurately applied and that the transistor T. 4 is in good condition. At $3\frac{3}{4}$ i. p. s. the discharging signal being smaller the stand off is not necessary. Also the tachometer amplifier does not amplify the frequency $1000/3$ sufficiently for dipping.
- f) The motor starts correctly but passes through normal speed and then returns to normal. This shows that the starter discharger is not functioning or functioning insufficiently. Its voltage should be measured and compared with the schematic. (Check the diode).

2) Faults of Control

Typical Case: When the accelerator is depressed the motor speeds up but when the button is released the speed of the motor does not fall to normal. This fault is particularly obvious when there is no tape in the machine.

Cause: The servo-amplifier passes current to the motor even when the discriminator does not call for it. This is generally caused by thermal current in the transistors. This trouble will arise on every equipment if the ambient temperature is sufficiently high. It is abnormal below 40°C-centigrade. Two possibilities must be considered:

- a) The motor has an abnormally high consumption which heats the servo amplifier. (See "Faults in Motors").
- b) One or more transistors of the servo amplifier have deteriorated (by over-heating, for example) and their standing current has become too high. Change these components, being careful not to over-heat when soldering. This fault will disappear when one short circuits to earth the bases of the suspected transistors. Each transistor base is connected to earth by a resistance. The disconnection of such resistances is sufficient to increase the fault. A resistance of this type is also contained in the discriminator.

3) Wow and Flutter

- a) Wow at the frequency of rotation of the capstan. Possible source:
 - Mechanical or electrical braking on the motor (see "faults in motors").
 - The tachometer wheel is eccentric giving a signal of which the amplitude varies more than 30%. The limiting amplifier can change this amplitude modulation into a phase modulation of the square wave. Such modulation will "mislead" the discriminator.
 - Tachometer wheel magnetised: This induces into the tachometer head a strong signal of very low frequency which passes through the tachometer amplifier and upsets the discriminator.
Demagnetise the wheel.

When one has sufficient and suitable equipment, this type of fault is very easy to localize. It is necessary to find out first whether the speed stabiliser is not able to compensate for a fault in the motor, or on the contrary, if it is the stabiliser which provokes the wow, having been upset by an incorrect voltage from the tachometer circuit.

b) Irregular Wow

The most likely cause is slipping of the tape. Try re-tensioning the pinch wheel. A pressure of one k.gram should give satisfactory results.
Check the tension of the tape according to the respective instruction sheet.

c) Flutter

A rapid flutter is caused by a break in the servo-amplifier feed-back chain. Too much feed-back increases the wow and could even set the circuit into oscillation. In the case of difficulty with a recorder of the first series modify the circuit to conform with the new schematic.

MOTOR

The motor of the Nagra is of the permanent magnet electrodynamic type and resembles a d'Arsonval galvanometer with central magnet. It may be the cause of a number of difficulties and the following notes are intended to assist in such cases:

- If the recorder refuses to start occasionally, even when one presses the accelerator button, but in general starts when one turns it lightly by hand, the surface of the commutator should be examined - see paragraph 5.
- If the recorder runs irregularly, see paragraph 5 and subsequently paragraph 6.
- If the recorder produces a flutter, check the smoothness of rotation of the motor. There must be neither rough spots nor perceptible play.
- If the motor shows speed up following excessive heating of the power transistor of the servo amplifier, see first paragraph 6, then 4 and 3, and finally 1.

1. Dismantling and de-magnetisation

The magnet is fixed in the assembly by a left hand threaded set screw. The winding surrounds it. To remove the rotor, after first having unscrewed the centre screw (normal right and thread), it is necessary to introduce a rod 3 mm in diameter into the hole in the rotor between two wires. Turning the rotor, if necessary, one can reach with the rod one of the two notches in the magnet and so unscrew it. This gives access to the central ball race of the assembly (type EL4ZZ). This ball race must be of very high accuracy, much superior to those of normal commercial type. In case of need, ask for replacements.

In taking out the rotor, it is essential (unless you have a magnetising machine of considerable power such as we have) to short circuit the magnetic circuit, otherwise the magnet will lose about 25% of its magnetism. One can do this by sliding the rotor into another iron tube of suitable size (internal diameter 56 mm, external diameter minimum 60 mm) in such a manner that the magnetic circuit is never opened.

In case of repairs on the field, one obviously cannot take this precaution. The considerable reserve of power of the motor ensures, nevertheless, that the recorder will still be usable. The consumption will however be higher and rapid rewinding will be slower. In such cases it is necessary to return the rotor to us. We will return it to re-magnetised and in a short circuiting type of tube from which it can be slid into the motor. To check that the magnet has not been partially de-magnetised the voltage required on no load should be measured, that is, without tape and without the pinch wheel being engaged, at 15 i. p. s. (600 r. p. m.) A motor in good condition requires $9 \text{ V} \pm 0.5 \text{ V}$. A motor de-magnetised by dismantling without a magnetic short circuit will need only 7,5 volts.

Later dismantlings will not increase the amount of de-magnetisation.

2. Open Circuit of Half the Rotor

Below there is a schematic of the motor. It can be seen that the current passes through two paths in parallel. Interruption of one of the paths does not prevent the motor from functioning but doubles its resistance. This is indicated by a less vigorous rewind and partly by an increase of the limiting voltage required for operation at 15 i. p. s. One localize this fault by measuring of the rotor. The normal value is 21 ohms but a rotor half open circuited will read 42 ohms.

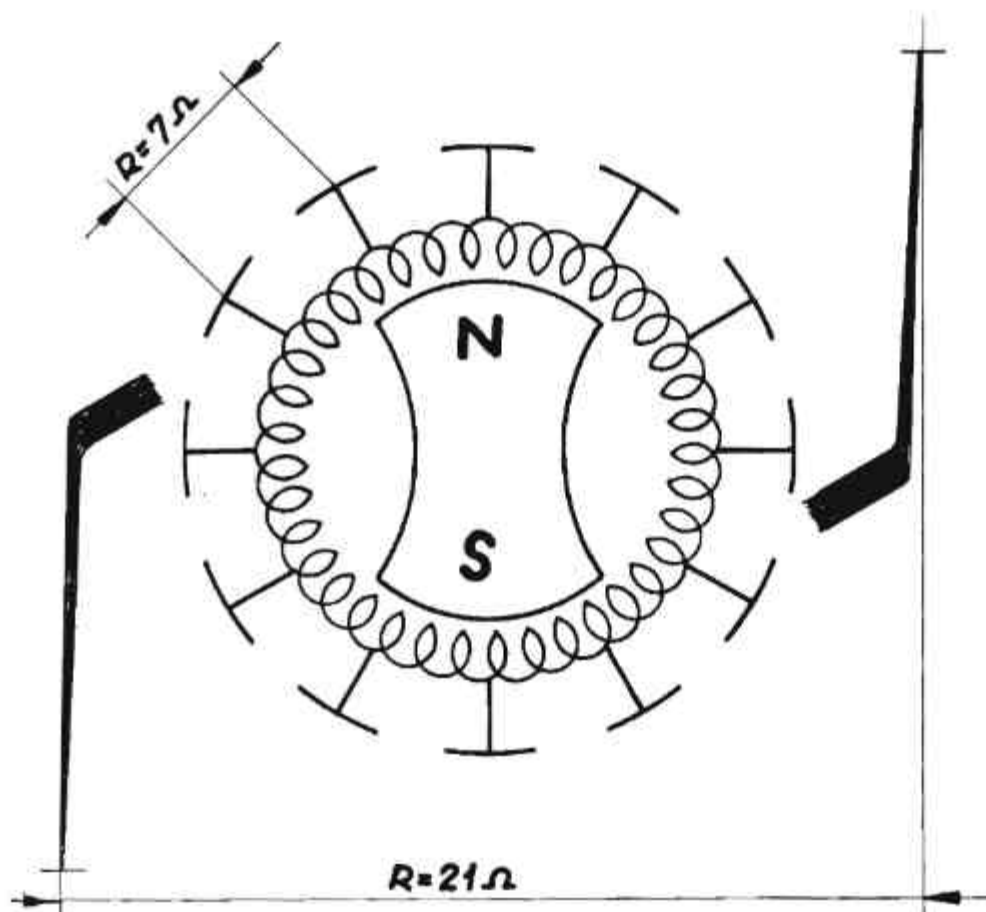

3. Short circuit between segments

A short circuit between two segments of the commutator has very serious repercussions; wow at double the speed of rotation of the capstan and increase in power consumption. Such a short circuit can happen in the windings or inside the commutator, but such cases are less likely in recorders which are in service. On the other hand, it is much more likely that a metallic deposit has appeared on the insulating segments of the commutator. To localize this kind of fault, it is necessary to measure the resistance between adjacent segments. It is usually between 6 and 8 ohms throughout the series. It increases regularly from the first to the last winding progressively from 1 to 1,5 ohms in all. Any abnormally low resistance found here indicates a fault. First of all the commutator should be cleaned with a very fine emery cloth, then washed carefully to eliminate

all traces of abrasive powder. If the fault continues, the corresponding wire of the coil should be disconnected. It is then possible to ascertain if the fault is in the winding or in the commutator. If the winding has short circuited, a new rotor should be ordered from us. On the other hand, it is often possible to repair the commutator by passing a very large current through the short circuit to break it down. The discharge of a 100 microfarad condenser charged to 300 volts will generally be sufficient.

4. Mechanical Friction

Mechanical friction of the rotor increases both the wow and the power taken. One can distinguish between electric braking, such as is shown in the preceding paragraph, because mechanical friction is constant, whereas the electric braking increases quickly when the motor speeds up. Typical values of the consumption of the motor on no load, that is without tape and with the pinch wheel not in contact with the capstan (but not on rapid re-wind) are given below:

<u>Speed</u>	<u>Normal no load current</u>	<u>No load current with two segments short circuited</u>
15 i. p. s.	26 ma	62 ma
7 1/2 i. p. s.	20 ma	39 ma
3 3/4 i. p. s.	17 ma	27 ma

5. Dirty Commutator

The commutator is obviously the most critical part of the motor. It is designed to work dry. It is therefore necessary to make sure that the commutator is perfectly dry. It can be cleaned by means of a piece of rag saturated with a solvent such as trichlorethylene or, better still, special cleaning fluid of electrical contacts. Certain of these products leave behind a very thin deposit of lubricant which seems not to prevent good running.

6. Misalignment of the Axis of Commutation

This axis of commutation, that is, the exact position of the brushes with respect to the centre magnet is very critical. A misplacement will provoke sparks at the commutator and electrical noise, and a considerable increase in current consumed. This increase may be sufficient to overheat the servo amplifier sufficiently to cause irregular running of the motor.

Use the following procedure for adjusting this position:

- Before moving the brushes mark their previous position.
- Start the motor at 15 inches per second measuring the current taken. The correct alignment corresponds to minimum consumption.
- If you find a noticeable difference (more than 5 mm on the external circumference of the motor), examine the fixing of the magnet.

A misplacement cannot happen except by a previous careless service work or by unscrewing or dismantling of the magnet. The left end thread on the magnet ensures that this cannot unscrew itself. On the other hand, it can happen when the adjustment mentioned above has been made and the magnet insufficiently well secured. In practice, it should be tightened up securely before re-adjustment.

If the difference is small, replace the brushes where they were because the difference is probably an error in measurement. Our factory-adjustment made by the aid of a special machine is much more accurate than that made by adjusting to minimum current.

PRECAUTIONS AGAINST INTERNAL NOISE

As with all tape recorders, the Nagra III has some residual noise. We must distinguish:

- 1) Noise in the microphone preamplifier
- 2) Noise in the record amplifier (output amplifier)
- 3) Noise in recording on the magnetic track
- 4) Noise in the play-back amplifier
- 5) Noise in the switching diodes of the speed standard selector
- 6) Noise in the play-back amplifier
- 7) For the second time noise in the output amplifier

Discussing the nature of these noises, we have:

- a) Hiss

This is approximately white noise, that is to say, composed of all frequencies in the spectrum. It resembles the noise of a jet of air or dry steam. It is quite clear but a little less than the pronunciation of the letter "S". Hiss is essentially produced by thermal agitation and has a limiting minimum value fixed for a given temperature and a given impedance. Similarly, the noise following the breakage of a connection on the input circuit is of this type.

- b) Semiconductor Noise (Flicker Noise)

This is similar to the preceding noise, but includes more low frequencies. Our ears are always less sensitive to low frequencies at low level, and semiconductor noise is distinguished by the fact that it is modulated by these low frequencies. The sound which most nearly describes this type of noise is that of a jet of vapour containing drops of liquid, for example, an espresso coffee machine. The noise is produced both by defective resistances carrying continuous current. In cases 1, 2, 4, 6 and 7 the transistors should be first suspect, then the base dividing resistances, and the collector resistances.

SPECIAL WARNING Do not dismantle your Nagra because of the results obtained with a doubtful tape. A bad tape can produce such noise on a perfect machine.

- c) Residual Noise at 1000, 2000 and 4000 c.p.s.

The speed stabilisation system of the Nagra uses these frequencies and it can happen that they may break through and become audible at the speed of $3\frac{3}{4}$ " per second which we do not consider "professional". A perceptible residual signal is allowed. On the other hand, it should not be possible to hear such

residuals during recording or play-back without signal on the other two speeds. The level in general will be better than -80 db.

Various forms of break-through are possible:

- On play-back induction between the motor and the replay head, or equally, induction between the tachometer head and the wiring to the replay head. A re-routing of these wires may reduce the trouble. One can diagnose this trouble by short circuiting the wires to the head on the H.F. filter on the chassis. A similar fault can be produced by damage to the discriminator filter or servo amplifier. It is normal that there should be some break through when the apparatus is working with the chassis opened.
- On record, the residual signal may come through induction into the microphone preamplifier and cable or by coupling to the input connection of the power amplifier and cable or finally, through the power leads or the earth leads. These residuals are adjusted to be negligible before delivery of the recorder. Should they appear, it is likely that a decoupling has deteriorated, or a change in earthing, or a misplacement of the connections.

d) Electrostatic Discharge

This consists of short sharp cracklings when the motor is in operation, at irregular intervals. They are caused by an electrostatic charge on the belt. A little brush is fitted to reduce them. This brush should almost touch the belt. In cases where these parasitic noises occur, verify that this brush has not been displaced.

e) Parasitic Noises from the Motor

These are caused by commutation of the motor. These are easily identifiable in that they are related to the rotation of the motor. They can be reduced to a great extent at the source by first checking that the commutator is in good clean order and that the brushes make good contact, and then by removing all possible paths of transmission between the motor and the amplifiers.

There are various routes:

- Magnetic induction. The rotor carries a current affected by parasitics and, therefore, generates a magnetic field containing parasitic components. Various screens of permalloy C are fitted to eliminate this and they should not be disturbed. It is normal that a certain level of parasitic noises should be observable when the recorder is open because part of the screening is on the bottom of the case.
- Electrical coupling at low frequency. The motor current has a parasitic component which is by-passed by smoothing condensers. The method of connections to earth has been very carefully designed and any modification can provoke the occurrence of parasitic noise.
- Electrical coupling at high frequency. The commutator, as with all contact breakers, behaves as a very small spark-type emitter. The consequent wave trains which are generated are very easily propagated and then rectified by a semiconductor, and there are a lot in the Nagra. This method of coupling is blocked by ferrite filters in the connecting leads.

- Motor spindle. The motor spindle turns in a ball race inside the motor and on a bearing holder underneath on the end plate. It can happen that a film of lubricating oil and, on the bearing holder, a layer of aluminium oxide which protects the bearing holder and the chassis from corrosion, becomes sufficiently insulating so that the spindle is no longer effectively earthed. In this case the parasitic in the motor find another route to earth. The parasitics so passing may in truth be extremely small but it is possible that this may happen. This trouble can be diagnosed when it is found that the noise disappears, then the spindle is earthed by touching the capstan with a wire to earth. In general, it is sufficient to eliminate these parasitics by carefully earthing the end bearing holder and removing the oxide on the seat of the screw holding the bearing holder, but in a very bad case a little metallic brush on the back of the capstan is obviously the most certain method.

INSIDE VIEW OF BOX

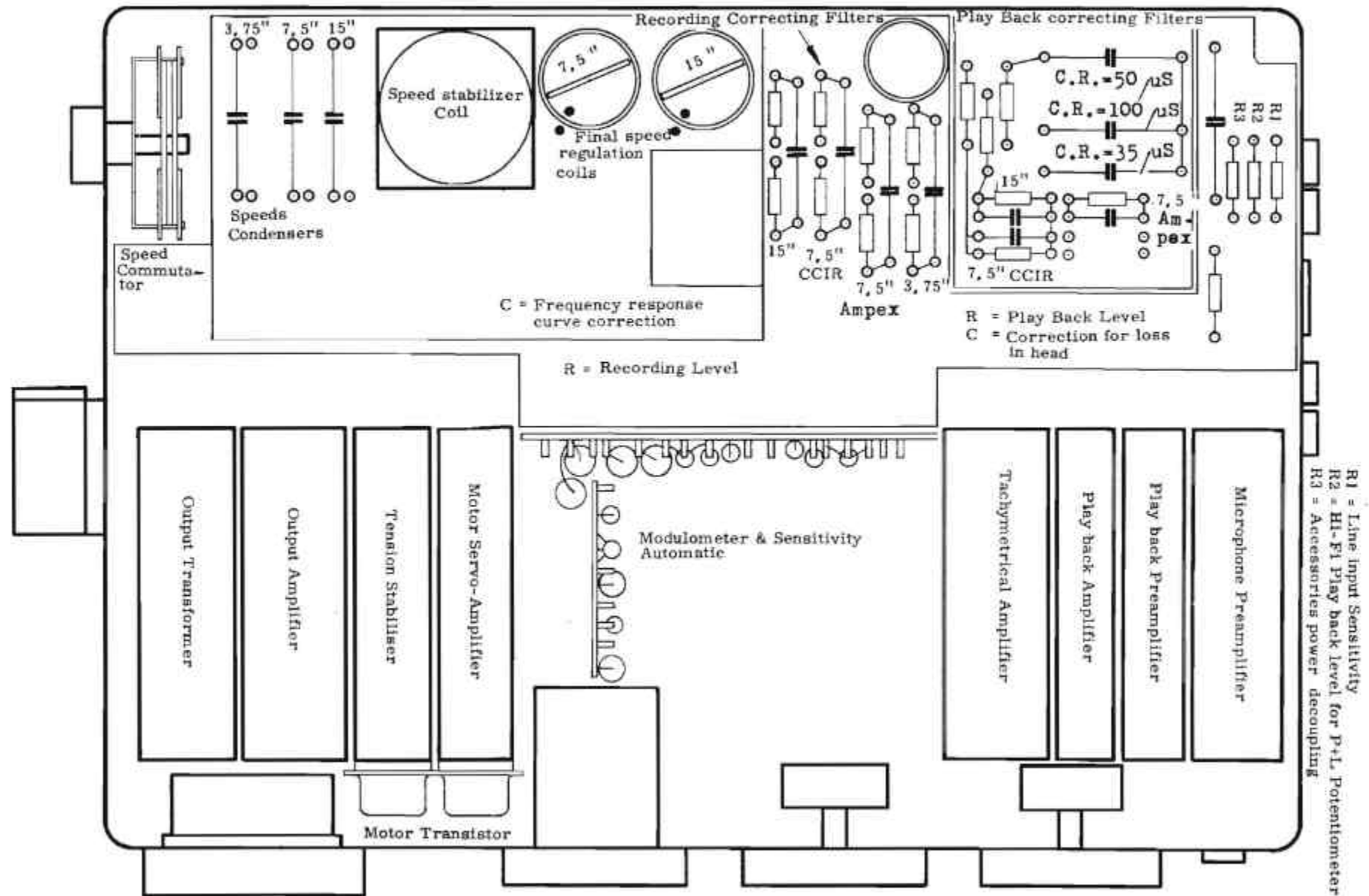

BOTTOM VIEW OF DECK PLATE

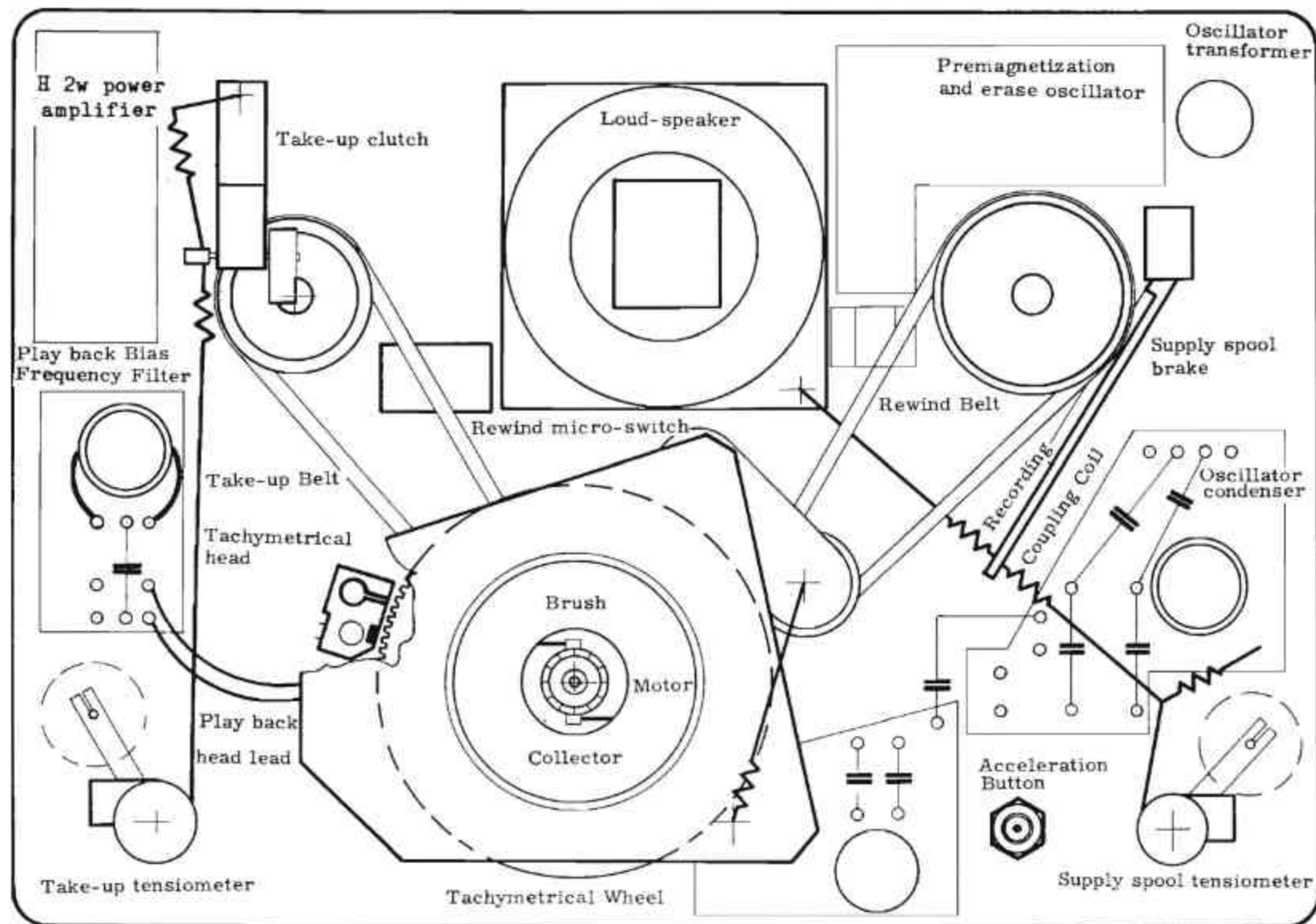

NAGRA III

MODIFICATION NOTE - BEFORE-AFTER MONITORING SWITCH

This Nagra is equipped with a push button which permits the selection of the sound source to the monitoring earphones during recording. One can select to monitor the signal already recorded, or the signal before it is recorded.

By pressing the BA switch (see photo below), the signal before recording is selected. When the button is not pressed, one has at the monitoring sockets, the signal as described in article No. 13 of the description of controls.



MODIFICATION NOTE - MICROPHONE PREAMPLIFIER

This Nagra is equipped with a new type of microphone preamplifier designated LN. This preamplifier permits the selection of input impedance between 50 ohms and 200 ohms. All that is necessary to do in order to change from one impedance to the other, is to rewire internally the connections on the input transformer. For wiring information, please refer to the mike preamplifier section of the Nagra wiring diagram included in the instruction manual dated May 1st, 1963.

KUDELSKI

6. ch. de l'Etang, Paudex - Lausanne, Switzerland

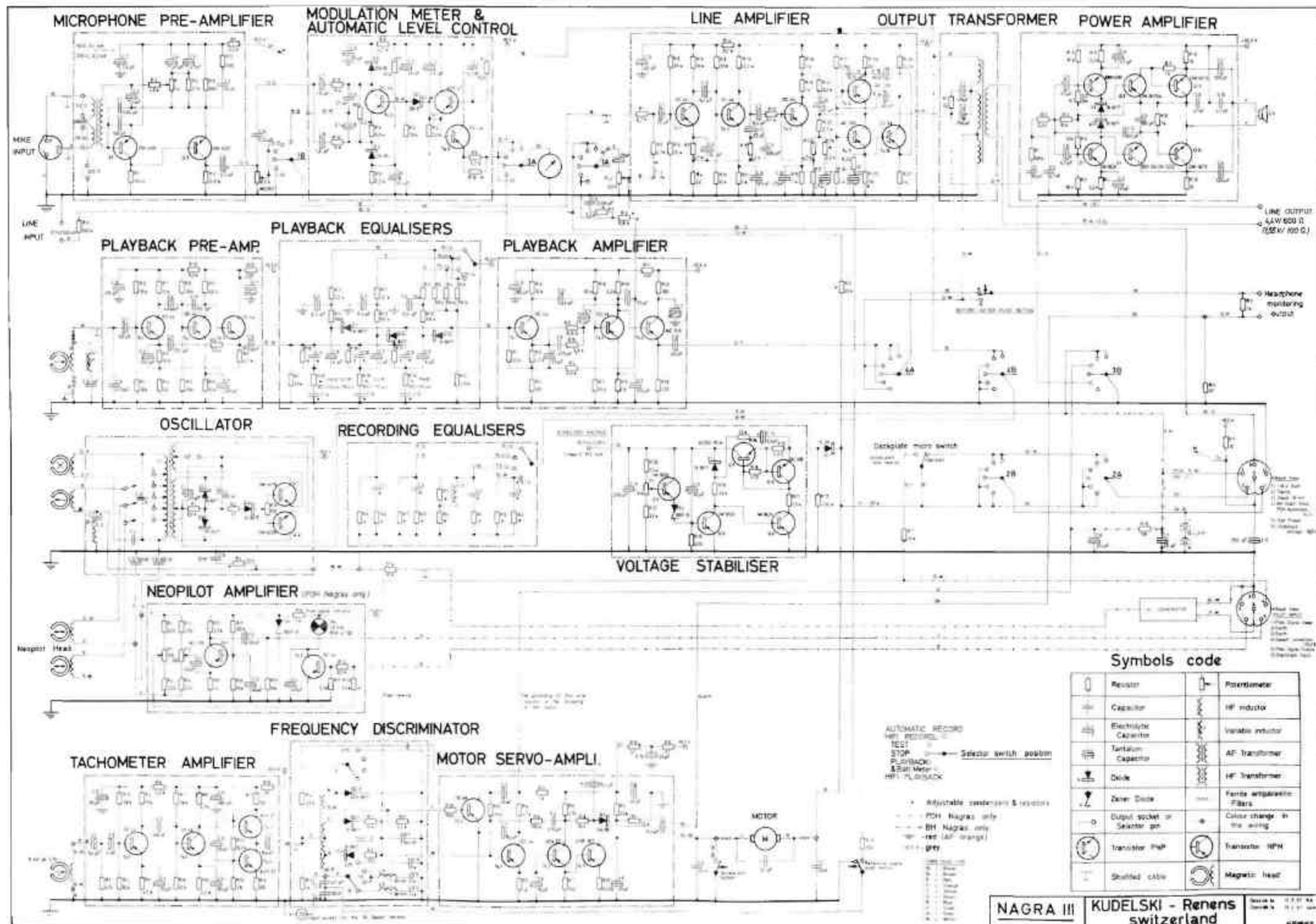

Symbols code

	Resistor		Potentiometer
	Capacitor		HF inductor
	Electrolytic Capacitor		Variable inductor
	Tantalum Capacitor		AF transformer
	Diode		HF transformer
	Zener Diode		Ferrite anti-parasitic Filter
	Duplex socket or Selector pin		Colour change in the wiring
	Transistor PNP		Transistor NPN
	Shielded cable		Magnetic head

Recording - Play Back

Enregistrement - Lecture

PAGE 2

13318

7.5"/s - NAB

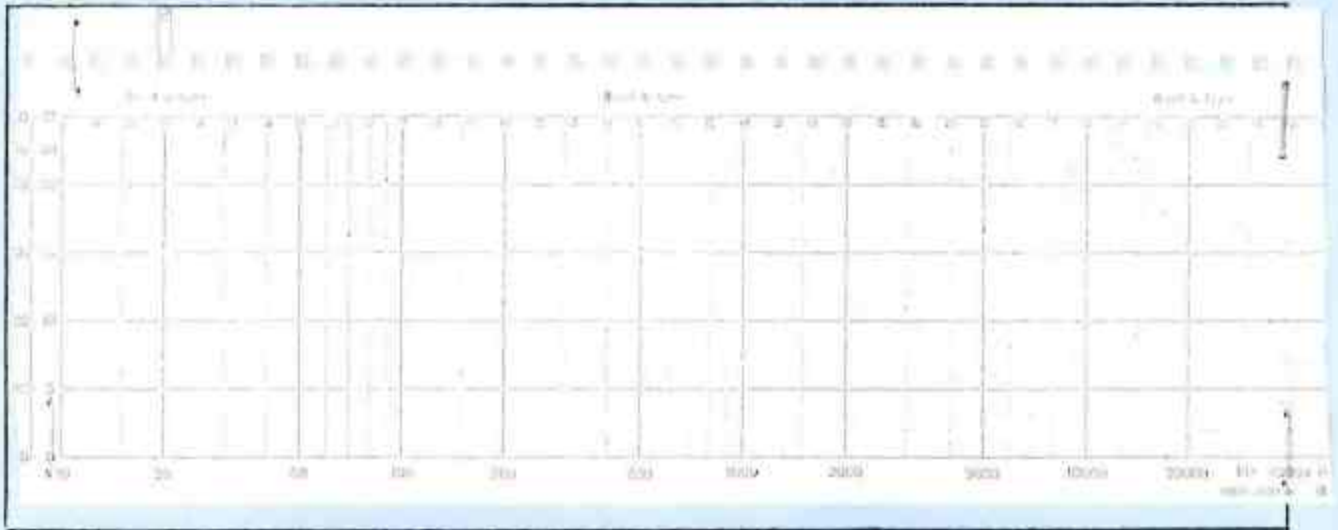

9.5 cm/s (3.75"/s)



Renens, 5.5.66 GAM/sj

FREQUENCY RESPONSE CURVES : RECORDING PLAY BACK

COURBES DE REPONSE : ENREGISTREMENT - LECTURE

13318

36 cm/s - CCIR (15"/e - NAB)

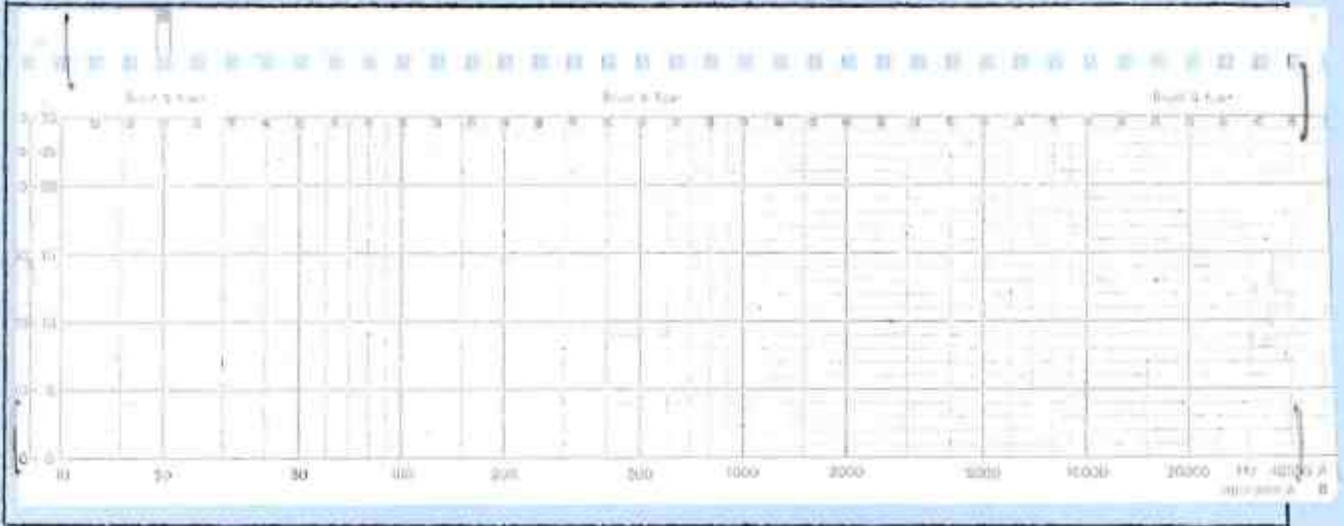

39 cm/s - CCIR



./.

FREQUENCY RESPONSE CURVE : PLAY BACK

COURBES DE REPONSE : LECTURE

13818

38 cm/s - CCIR (15"/s - NAB)

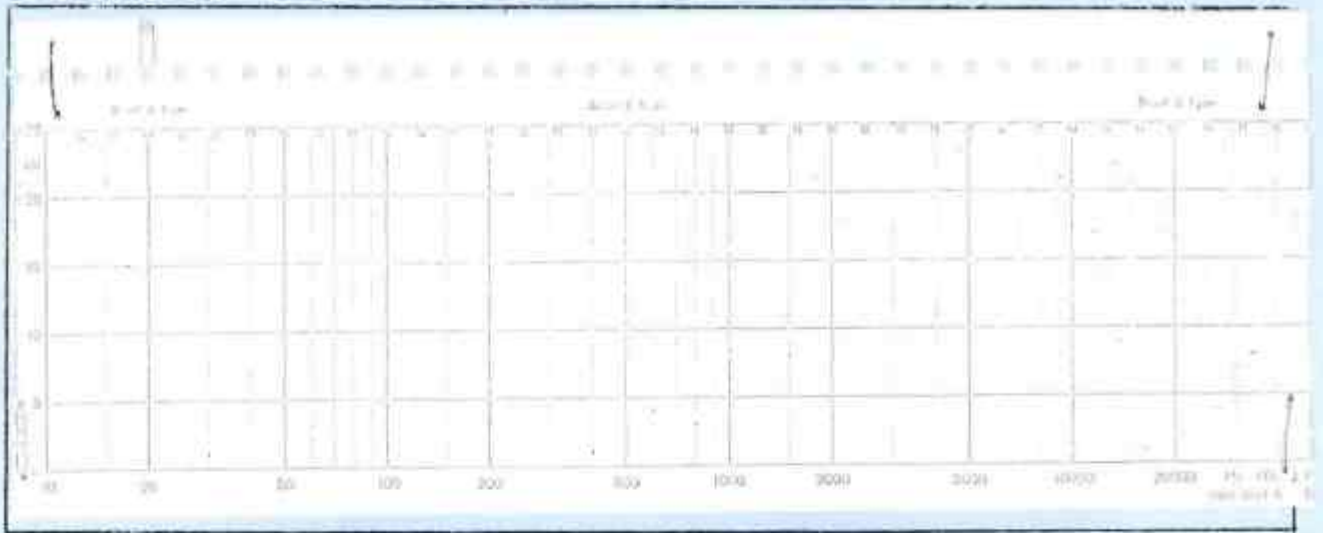

19 cm/s - CCIR

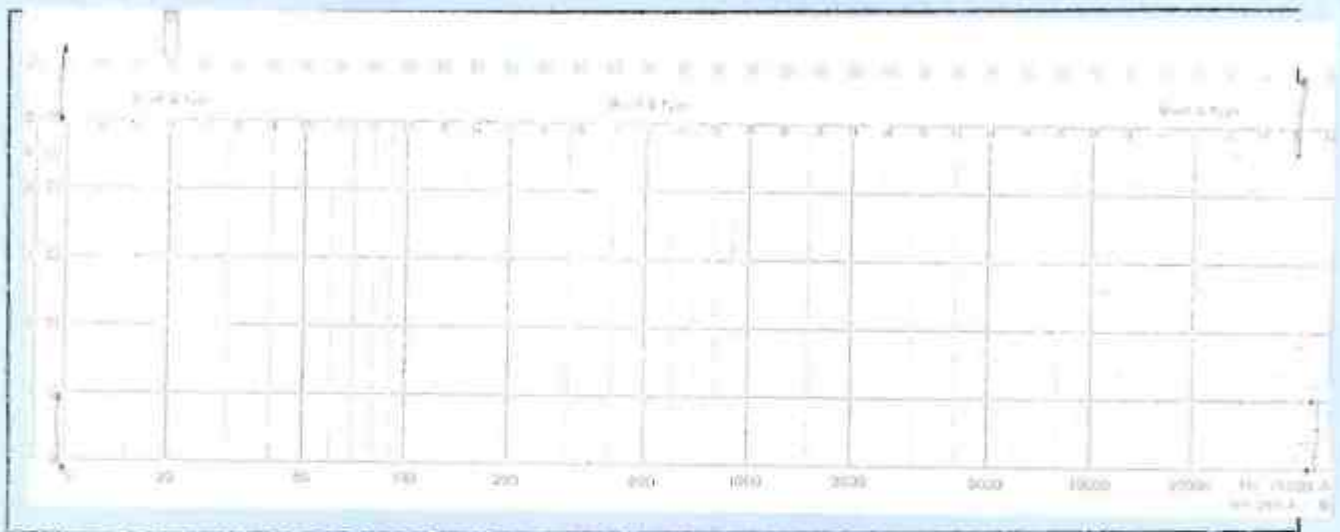

7.5" - NAB

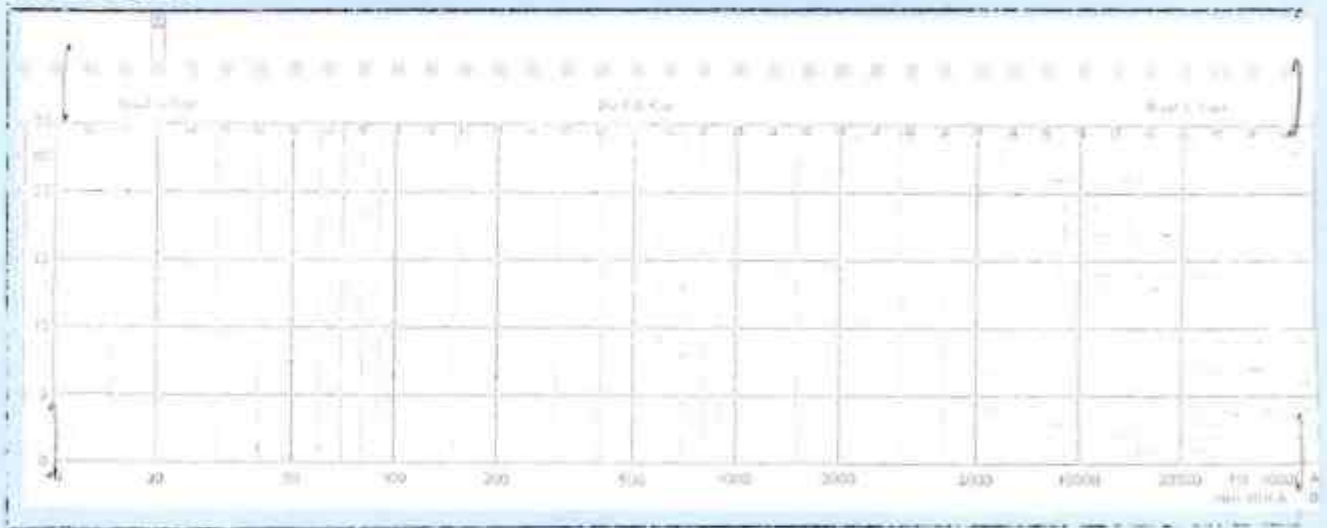

REMARKS: 3 S. 20 GAN/81

NAGRA III

N°: 13818

TYPE: 81 1183

FINAL QUALITY CONTROL
INSPECTION REPORT

PROTOCOLE DES ESSAIS
ET MESURES DE SORTIE

NOMINAL OUTPUT LEVEL (0 db)
Niveau de sortie nominal (0 db)

4.4 V

TAPE FOR WHICH THE BIAS AND FREQUENCY
RESPONCE IS ADJUSTED

Ruban pour lequel la prémagnétisation
et les courbes de réponse ont été ajustées

Scotch 102

MICROPHONE PREAMPLIFIER WIRED FOR
Préampli Micro connecté pour

200 OHMS

FINAL CHECK
Contrôle final

A. ButHex

Date: 4 10 68

KUDELSKI

60, rue de Lausanne - 1020 RENENS - SWITZERLAND

* See attached explanations	* Voir explications ci-après	
DESCRIPTION OF TESTS	DESCRIPTION DES CONTROLES	
1) Visual and mechanical inspection	1) Contrôle visuel et mécanique	-
2) Pinch wheel pressure Feed tape tension of the tape Take up tension	2) Pression de contact du contre-cabestan Tension de débit du ruban Tension d'embobinage	<u>350</u> g <u>15</u> g <u>34</u> g
3) Tachometric head voltage at 3,75"/s	3) Tension tachymétrique à 9,5 cm/s	<u>3</u> mV
4) CURRENT CONSUMPTION * TEST PLAYBACK at 7,5"/s RECORD at 7,5"/s (Beginning of a 5" reel)	4) CONSOMMATION DE COURANT * TEST PLAYBACK à 19 cm/s RECORD à 19 cm/s (Début de bobine 5")	<u>88</u> mA <u>152</u> mA <u>130</u> mA
5) No speed overshoot of starter circuit *	5) Pas d'emballlement au démarrage *	-
6) SPEED CONTROL Absolute speed * Drop of speed due to braking of the capstan *	6) CONTROLE DE VITESSE Vitesse absolue * Baisse de vitesse par freinage du cabestan * 15" 7,5" 3,75"	<u>-0,8</u> % <u>-0,2</u> % <u>-0,4</u> %
7) Wow and flutter Peak value *	7) Pleurage et scintillation Valeur de pointe * 15" 7,5" 3,75"	<u>0,07</u> % <u>0,03</u> % <u>0,14</u> %
8) Battery voltage limit Limit voltage at 15"/s * Limit voltage of Modulometer *	8) Tension limite des piles Tension limite à 38 cm/s * Tension limite au Modulomètre *	<u>11,3</u> V <u>12,3</u> V
9) Subjective tests with mike, earphones and loudspeaker	9) Essais subjectifs avec microphone, casque et haut-parleur	-
10) Phase control of reproduce and recording heads and output transformer	10) Contrôle de phase des têtes d'enregistrement et de lecture et du transformateur de sortie	-
11) Reference signal Start-stop for BH only	11) Signal de référence Start-stop pour BH	- -

<p>12) OUTPUT AMPLIFIER</p> <p>Line input sensitivity</p> <p>Accessory socket input sensitivity</p> <p>Distorsion: H_2 (at 0 db - 1000 c/s) H_3</p> <p>Signal to Noise ratio</p> <p>Line output level</p> <p>Modulometer reading</p>	<p>12) AMPLIFICATEUR DE SORTIE</p> <p>Sensibilité d'entrée ligne</p> <p>Sensibilité d'entrée accessoires</p> <p>Distorsion H_2 (à 0 db - 1000 Hz) H_3</p> <p>Rapport signal/bruit</p> <p>Niveau de sortie ligne</p> <p>Indication du modulomètre</p>	<p><u>0,47</u> V</p> <p><u>8,5</u> mV</p> <p><u>0,3</u> %</p> <p><u>0,2</u> %</p> <p><u>-75,5</u> db</p> <p><u>4,4</u> V</p> <p><u>+0,1</u> db</p>
<p>13) PLAYBACK CHAIN</p> <p>Signal to Noise ratio</p> <p>Tachometric signal rejection</p>	<p>13) CHAINE DE LECTURE</p> <p>Rapport signal/bruit</p> <p>15"-</p> <p>19 cm-CCIR</p> <p>7,5"- NAB</p> <p>Résidu tachymétrique</p>	<p><u>-73</u> db</p> <p><u>-72</u> db</p> <p><u>-72</u> db</p> <p><u>~</u></p>
<p>14) Reproduce signal level at 0 db - 15"/s *</p> <p>Monitoring PLAYBACK</p> <p>Line Hi-Fi PLAYBACK</p>	<p>14) Niveau de lecture à 0 db - 38 cm/s *</p> <p>Monitoring PLAYBACK</p> <p>Ligne Hi-Fi PLAYBACK</p>	<p><u>300</u> mV</p> <p><u>4,4</u> V</p>
<p>15) Recorded signal level at 0 db - 15"/s</p> <p>Monitoring RECORD</p> <p>Distorsion: H_2 H_3</p>	<p>15) Niveau d'enregistrement à 0 db - 38 cm/s</p> <p>Monitoring RECORD</p> <p>Distorsion: H_2 H_3</p>	<p><u>305</u> mV</p> <p><u>0,3</u> %</p> <p><u>1,5</u> %</p>
<p>16) Erasure *</p>	<p>16) Effacement *</p>	<p><u>-78</u> db</p>
<p>17) MIKE PREAMPLIFIER</p> <p>Signal to Noise ratio</p> <p>Sensitivity</p> <p>Frequency response</p> <p>Automatic level Control</p>	<p>17) PREAMPLI MICRO</p> <p>Rapport signal/bruit</p> <p>Sensibilité</p> <p>Réponse en fréquence: 30 Hz 18 kHz</p> <p>Compresseur automatique</p>	<p><u>-126</u> dbm</p> <p><u>0,13</u> mV</p> <p><u>-0,4</u> db</p> <p><u>-0,6</u> db</p> <p><u>~</u></p>
<p>18) PILOTTONE SYSTEM *</p> <p>Reproduce signal level</p> <p>Recorder signal level</p> <p>Clapstick signal</p> <p>Sound-Pilottone rejection</p> <p>Pilottone-Sound rejection</p> <p>Closed-loop speed control with SLO</p>	<p>18) SYSTEME NEO-PILOTE *</p> <p>Niveau de lecture 50 μV</p> <p>Niveau d'enregistrement</p> <p>Claquette</p> <p>Résidu Son- Pilote</p> <p>Résidu Pilote-Son</p> <p>Asservissement de vitesse avec SLO</p>	<p><u>50</u> μV</p> <p><u>50</u> μV</p> <p><u>~</u></p> <p><u>~</u></p> <p><u>-65</u> db</p> <p><u>~</u></p>

TECHNICAL COMMENTS ON THE TESTS

4) Current consumption

The supply voltage shall be 18 V.

5) No speed overshoot of starter circuit

This test shall be carried out with a supply voltage of 24 V.

6) Speed control

Average speed stability (or absolute speed).
Note: This measurement can be carried out with the aid of a standard test tape and a frequency meter, or with the aid of the stroboscopes which are found on top of the flutter filters. A displacement of one point in 10 seconds, corresponds to a speed error of 0.1%.

It is well to remember that one quarter of a non-tempered tone, corresponds to a frequency variation of 3%. Therefore, an error of 0.3% in absolute speed, corresponds to a pitch variation of 1/40 of a tone.

NOTICE: It is imperative to use a crystal controlled light source when checking the stroboscopes. The frequency error of the mains, are in general larger than the speed error of the NAGRA. The reason for which precision of this order is important, is the application of the NAGRA in telemetry.

In our test laboratory, the 3 speeds of 15", 7,5" and 3,75" are adjusted by means of a speed standard test tape on which a signal of 1000 c/s $\pm 0,1\%$ has been recorded, and our WFM speed me-

COMMENTAIRES TECHNIQUES SUR LES MESURES

4) Consommation de courant

La tension d'alimentation est de 18 V.

5) Pas d'emballement au démarrage

On procède à cet essai avec une tension de 24 V.

6) Contrôle de vitesse

Stabilité de la vitesse moyenne (ou vitesse absolue). Note: Cette mesure peut se faire soit avec un ruban étalon et un fréquencemètre au discriminateur, soit à l'aide de stroboscopes placés sur les guides rotatifs. Le déplacement d'un point en 10 secondes correspond à un écart de vitesse de 0,1%.

Rappelons qu'un quart de ton tempéré correspond à une variation de fréquence de 3%. Une erreur de vitesse absolue de 0,3% équivaut donc à 1/40 de ton.

ATTENTION: Pour des mesures précises, il faut utiliser une source de lumière pulsée, pilotée par quartz; les écarts de fréquence du secteur étant souvent supérieurs à ceux du NAGRA. La recherche d'une si grande précision dans ce domaine est justifiée par les applications du NAGRA en télémesure.

Dans notre laboratoire de contrôle, les 3 vitesses de 38,1 cm, 19,05 et 9,5 cm/s sont réglées avec une bande de vitesse-étalon ayant une fréquence de 1000 $\pm 0,1\%$, ainsi que notre instrument

ter having a calibrated discriminator.

Drop of speed due to braking of the capstan

This test is carried out by braking of the capstan until the motor current consumption reaches twice the normal one. The purpose of this test is to check the safety margin of the servo-amplifier.

7) Wow and Flutter

This test is carried out in PLAYBACK by means of a standard test tape. The reading is taken on our WFM instrument, which gives the peak value of the weighted wow and flutter according to the DIN 45507 specifications.

8) Battery voltage limit

Recording and playing back simultaneously while lowering the power supply voltage. The limit voltage is the supply voltage at which the alarm signal appears. The recorder should function correctly down to that voltage.

Test conditions: (worst case)

Speed: 15"/s

End of a 7" reel

Limit voltage of Modulomètre

It is that supply voltage which corresponds to the red mark on the Modulometer. The reading is made in PLAYBACK. This voltage is lower than 12,5 V. Its value is generally higher than the latter by 0,5 V. (worst case)

de mesure WFM équipé d'un discriminateur étaloné.

Baisse de vitesse par freinage du cabestan

On procède à cette mesure en freinant le cabestan jusqu'à ce que la consommation du moteur atteigne le double de la valeur normale. Ceci a pour but de vérifier la réserve de marche de l'asservissement.

7) Pleurage et scintillement

Cette mesure est faite en PLAYBACK au moyen d'une bande-étalon.

La valeur est mesurée sur notre instrument WFM, qui donne la valeur de pointe du pleurage, après passage dans un filtre de pondération prévu par la norme DIN 45507.

8) Tension-limite des piles

Enregistrer et lire simultanément tout en baissant la tension d'alimentation. La tension limite est la tension pour laquelle le signal d'alarme apparaît. L'appareil doit fonctionner correctement jusqu'à cette tension.

Conditions de mesure: (cas le plus défavorable)

Vitesse: 38 cm/s

Fin de bobine 7"

Tension limite du Modulomètre

C'est la tension d'alimentation correspondant à la marque rouge au Modulomètre. La lecture se fait en PLAYBACK. Cette tension doit être inférieure à 12,5 V. Sa valeur est généralement de 0,5 V supérieure à la tension limite définie ci-dessus. (cas le plus défavorable)

9) Reproduce signal level

The 0 db (= 4,4 V Line Output) correspond to a r.m.s. value of the recorded flux of 200 milliMaxwells on the tape. This test is carried by means a level test tape.

16) Erasure

We guarantee an erasure of at least 75 db for a signal recorded on a Scotch tape type 102 at the level of 200 mMx.

Measurement

An 800 c/s signal is recorded at 0 db, with a tape speed of 15"/s, and then erased using the internal facilities. The ratio between the signal, as recorded and the non-erased residue gives the efficiency of the erasure.

Signal to Noise ratio

The measurement is performed with the "A" weighting network in accordance to I.E.C. standards for Precision Sound Level Meters (Helsinki 1961)

The "A" weighting network of the I.E.C. is practically the same as the ASA A american specifications.

In our test laboratory the reading is made on a Brüel & Kjaer Audio Frequency Spectrometer type 2112.

9) Niveau de lecture

Le niveau 0 db (= 4,4 V à la sortie ligne) correspond à la valeur efficace d'un flux de 200 milliMaxwells sur la bande. Cette mesure est opérée au moyen d'une bande étalon de niveau.

16) Effacement

Nous garantissons un effacement de 75 db ou mieux d'un signal enregistré sur ruban Scotch 102 au niveau de 200 mMx.

Procédé de mesure

On enregistre au niveau 0 db un signal de 800 Hz à 38 cm/s puis on efface avec l'appareil. Le rapport entre le signal non effacé donne l'efficacité de l'effacement.

Rapport Signal/Bruit

La mesure est faite avec le filtre de pondération "A" prévu par les normes internationales de la C.E.I. sur les mesures acoustiques (Helsinki 1961)

Le filtre "A" prévu par les normes C.E.I. est pratiquement le même que le filtre ASA A des normes américaines.

Dans notre laboratoire de contrôle la mesure est réalisée au moyen de l'analyseur Brüel & Kjaer type 2112.