

# TASCAM

TEAC Professional Division

# 32

2-Track Recorder/Reproducer



**OPERATION/MAINTENANCE**

5700029103

The guarantee of performance that we provide for the 32 must have several restrictions. We say that the recorder will perform properly only if it is adjusted properly and the guarantee is that such adjustment will be possible. However, we cannot guarantee your skill in adjustment or your technical comprehension of this manual. Therefore, Basic Daily Setup is not covered by the Warranty. If your attempts at internal adjustments of such things as rebias and record EQ trim are unsuccessful, we must make a service charge to correct your mistakes.

Recording is an art as well as a science. A successful recording is often judged primarily on the quality of sound as art, and we obviously cannot guarantee that. A company that makes paint and brushes for artists cannot say that the paintings made with their products will be well received critically. The art is the province of the artist. TASCAM can make no guarantee that the 32 in itself will assure the quality of the recordings you make.

Your skill as a technician and your abilities as an artist will be significant factors in the results you achieve.



**CAUTION**  
HIGH VOLTAGE ELECTRIC SHOCK  
DO NOT OPEN



**CAUTION: TO REDUCE THE RISK OF ELECTRIC SHOCK, DO NOT REMOVE COVER (OR BACK). NO USER-SERVICEABLE PARTS INSIDE. REFER SERVICING TO QUALIFIED SERVICE PERSONNEL.**



The lightning flash with arrowhead symbol, within an equilateral triangle, is intended to alert the user to the presence of uninsulated "dangerous voltage" within the product's enclosure that may be of sufficient magnitude to constitute a risk of electric shock to persons.



The exclamation point within an equilateral triangle is intended to alert the user to the presence of important operating and maintenance (servicing) instructions in the literature accompanying the appliance.

**WARNING: TO PREVENT FIRE OR SHOCK HAZARD, DO NOT EXPOSE THIS APPLIANCE TO RAIN OR MOISTURE.**

# TABLE OF CONTENTS

Introduction to the 32 and Its Design			
Philosophy	3		
Features and Controls	4		
Basic Information	8		
Entering "Record"	9		
Voltage Conversion	11		
Note for U.K. Customers	11		
Connection and Operation of the DX-2D	12		
M-30 Recording Mixer	15		
Accessory Information	17		
Specifications of the 32	19		
The dB: Who, What, Why	21		
Impedance Matching and Line Levels	25		
Reference Levels	27		
Calibration	29		
More Information is Available	30		
<b>THEORY OF OPERATION-MAINTENANCE</b>			
Cleaning	32		
Degaussing (Demagnetizing)	33		
Test Equipment/Materials	33		
1) Alignment Tapes	33		
2) VTVM or FET Multimeter	36		
3) Signal Generator or Oscillator	36		
4) The Oscilloscope	37		
5) Test Tapes for the 32	39		
Electrical Adjustment Procedure	40		
1) Location of Electrical Adjustments	40		
2) Reproduce Calibration	41		
3) Input Calibration	42		
4) About the Bias	43		
5) Bias Level Adjust	44		
6) Bias Trap Adjust	45		
7) Record Level Adjust	45		
8) The Peak Adjust Circuit	46		
Daily Setup	47		
General Advice on Maintenance	48		
Service Chart	49		
<b>MAINTENANCE</b>			
<b>1. Circuit Description</b>			
1-1. Logic Used in the Tape Deck	53		
1-2. System Control IC	53		
1-2-1. Pin Assignments and their Functions	53		
1-2-2. Block Diagram	54		
1-2-3. Input Signals and Resulting Modes	54		
1-2-4. Mode Transition	55		
1-2-5. Operation with more than One Input Signal	55		
1-2-6. Input/Output Levels	55		
1-2-7. Initial Reset Circuit	56		
1-3. Power Shut-Off Circuit	56		
1-4. Capstan and Brake Solenoid Drive Circuit	57		
1-5. Reel Motor Drive Circuit	59		
1-6. Tape Direction Sensing and Counter Clock Generation Circuit	61		
1-7. Counter Clock Pulse	62		
1-8. Motion Sensing Circuit	62		
1-9. F.F. and REW Operation	63		
1-10. Electrical Brake System	63		
1-11. Counter Zero Return	65		
1-12. Punch In/Out Control Circuit	67		
1-13. Edit Control Circuit	69		
1-14. Rec and Play Mute Signals	69		
1-15. Display Circuit	70		
1-16. Amplifier Circuit Description	71		
1-16-1. Power Muting Circuit	71		
1-16-2. Bias and Record Control Circuit	72		
1-16-3. Reproduce Amplifier Circuit	74		
<b>2. Checks and Adjustments</b>			
2-1. Essential Test Equipment Required	77		
2-2. Removing the Panels of the Deck	78		
2-3. Capstan Thrust Clearance	79		
2-4. Brake Mechanism	79		
2-5. Brake Torque	79		
2-6. Reel Motor Torque	80		
2-6-1. Take-Up Torque	80		
2-6-2. Back Tension	81		
2-7. Pinch Roller Pressure	81		
2-8. Reel Table Height Adjustment	82		
2-9. Tape Speed	82		
2-10. Wow and Flutter Check	82		
2-11. Record/Reproduce Amplifier Checks and Adjustments	83		
Preliminary Adjustments	83		
2-11-1. Input Level Calibration	85		
2-11-2. Input Meter Calibration	85		
2-11-3. Reproduce Level Calibration	85		
2-11-4. Reproduce Meter Calibration	86		
2-11-5. Reproduce Frequency Response	86		
2-11-6. Bias Tuning and Bias Trap Adjustments	86		
2-11-7. Recording Bias Adjustment	87		
2-11-8. Recording Level Adjustment	88		
2-11-9. Frequency Response (Overall)	88		
2-11-10. Signal-to-Noise Ratio (Overall)	89		
2-11-11. Erase Ratio	89		
2-11-12. Channel Crosstalk	89		
2-11-13. Distortion	90		
2-11-14. Headphones Output Level	90		
2-11-15. Mic Level Check	90		
<b>3. Exploded Views and Parts List</b>	91		
Schematic Diagrams	Insert		

\* The M-30 Recording Mixer is optionally available.

## Introduction to the 32 and Its Design Philosophy

No matter how elaborate a multichannel tape recorder is, it doesn't do the job without help. A lot of equipment is involved, and a lot of talent as well. The recorder becomes the keystone in a system that involves microphones, mixers, loudspeakers, amplifiers and many sophisticated electronic devices. Everything contributes a part to the system of multichannel recording.

In this general purpose 2 channel recorder/reproducer we have included the features, circuits and controls necessary for a wide variety of applications. For example, true stereo remote recording with a minimum amount of extra equipment is made possible by the inclusion of microphone preamplifiers, pads and headphone amps.

Either channel may be recorded while auditioning the other in true "sync" (overdub capability) and a recording can commence while the tape is rolling (true multitrack "punch-in" is possible).

CUE and EDIT logics are both supported, and follow the generally accepted procedures that professional engineers have made "standard". Hand CUE, DUMP EDIT, and independent signal selection for the reproduce amplifiers regardless of record status make the 32 a useful tool in the business of recording,

whatever that business is, multitrack, multimedia, remote stereo or fixed location studio operation.

It has long been our contention that professionalism is defined by people and what results they achieve. It's not something that automatically happens when you buy a tape machine with a lot of tracks, or at a very high price. It's what you do with the equipment and how well you do it that makes the point.

In designing the 32, we believe we have been guided by the multichannel system as it truly is. We are sure our recorder/reproducer can deliver the performance necessary to achieve solid results.

If you would like to comment on our design philosophy, please feel free to contact us. Criticism and comment from our owners has helped us improve our products and our business. We welcome all feedback.

Please send in the warranty card. Although it is not absolutely necessary to insure warranty protection, it will allow us to learn some things about who you are and what you do with tape. From time to time we mail out literature and information of interest to the multichannel recordist. Let us know where you are and we'll keep in touch.

\*dbx is a trademark of dbx Incorporated. dbx noise reduction system manufactured under license from dbx Incorporated.

This recorder/reproducer has a serial number located on the rear panel. Please record the model number and serial number and retain them for your records.

Model number \_\_\_\_\_

Serial number \_\_\_\_\_

### Note:

If you notice any differences, either on the outside or the inside of the unit from the illustrations and descriptions in this manual, talk to your dealer. He may have revision sheets that will show manufacturing changes, or notifications of how to deal with any changes in set-up or maintenance procedures. Save this manual, refer to it when necessary, and good luck with your 32.

## FEATURES AND CONTROLS

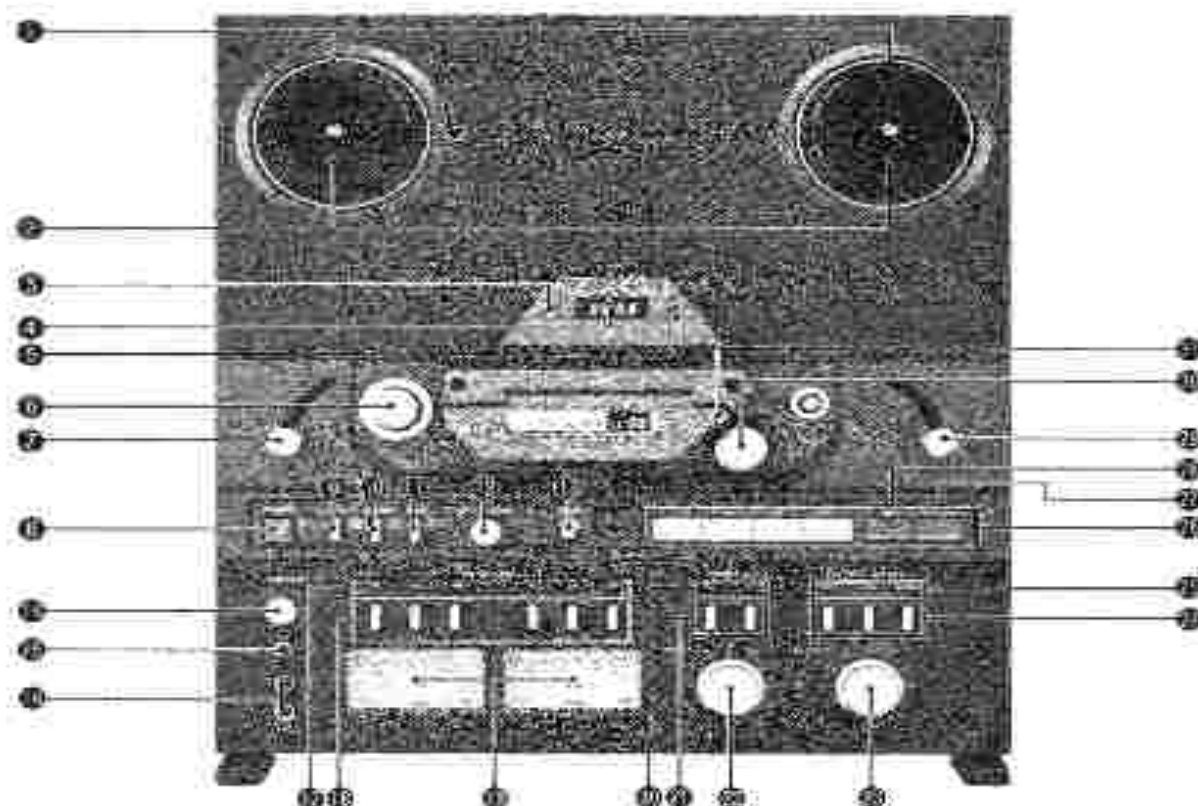

### 1 Reel Tables

Support either 7" reels or hub adaptors when 10-1/2" reels are used. Use the same size and kind of reels. See page 8 for details.

### 2 NAB Hub Adaptors

These can be installed to allow use of 10-1/2" reels. Rotate adaptor ring CW to fully tighten.

### 3 ZERO RETURN Button

When depressed, counter 0000 may be considered a one position "autolocator" allowing rewind (◀) to find one spot (0000) on the tape without the use of the cue lever. You won't need an audible cue to find this location, and accidents to the tape or damage to the monitor system tweeters will be avoided. This auto stop function is only possible in rewind (◀), the transport will not stop at 0000 if you are using (▶) fast forward.

1. If the rewind time is short, the transport will stop at 999, not precisely on the "mark", but very close.

2. If the rewind time is long (half a reel of tape) the transport will cycle between (◀) and (▶) several times and finally come to rest at counter 999.

Tape slippage will lower the accuracy of the "stop" point. So, always check by listening before re-recording. You may not be exactly

"on-cue". Take care.

### CAUTION:

Once the ZERO RETURN operations are completed, make sure to reset this button to (OFF).

### 4 Digital Counter

A 4-digit counter.

### 5 RESET Button

Press this button to obtain "0000" when determining the record start position of the ZERO RETURN position.

### 6 Impedance Roller

### 7 Tension Arm

### 8 POWER Switch

When depressed (ON), the digital counter and VU meters light. Press again (OFF) to turn off.

### 9 REEL Switch

When large diameter 10-1/2" reels are used, greater back tension is required for correct operation. 7" reels require less back tension. This switch sets the correct amount of back tension; set it to suit the size of reel you are using on the supply side.

#### Ⓢ SPEED Switch

LOW ( = ) selects a tape speed of 7-1/2 ips and HIGH ( □ ) selects a tape speed of 15 ips.

#### Ⓢ EDIT Switch.

Depress to activate, depress again to release.

#### CAUTION:

Edit mode may only be activated safely from STOP. When this button is depressed, the takeup reel motor is released from transport logic control. If the recorder is in either fast forward or rewind, and the EDIT button is depressed, only the STOP and PLAY buttons will function. Fast motion in either direction will not be accepted as a command after STOP until the EDIT button is released. This protective restriction must be included in the logic or the transport may spill tape uncontrollably.

This EDIT feature is used in this way:

When EDIT is depressed, pressing PLAY ( ▶ ) activates the capstan motor and the pinch roller solenoid regardless of the position of the takeup tension shutoff arm. The takeup reel will not move, and the tape will "spill". This will allow you to listen to the playback of an unwanted section without winding that part of the tape onto the takeup reel. When you hear that the section that you wish to remove (edit out) has completely "spilled", or "dumped", a splice can be made, the desired parts can be joined together, and the unwanted length of tape discarded. As you can see, the "safety features" such as brakes and tape tension detection must be bypassed in order to provide these edit capabilities, so take care.

#### Ⓢ PITCH CONTROL PULL ON Control

Permits a +12 % variation of the tape speed in the recording or reproducing modes.

Pull out and turn to the left ( - ) to decrease the speed of the tape transport; turn to the right ( + ) to increase the transport speed.

Push in to disengage.

#### NOTE:

Since this pitch control is active in record as well as reproduce, it is wise to check and make sure that it is disengaged (pushed in) when not wanted.

#### Ⓢ CUE Lever

This control will defeat the fast motion tape lifters. The more pressure you apply, the closer the tape will come to the heads. This will allow the reproduce signal to be heard in fast motion for cueing. Use only enough pressure to hear the signal. Too much signal will damage the electronics, and if your monitor system is

turned up, high frequency playback signal will damage your loudspeakers so be sure the cue lever is not engaged (locked) when in fast motion. The latch position is provided only for hand winding the tape to find an edit point. Push down on the lever to release.

#### CAUTION:

Use of the cue lever in fast forward or rewind will greatly accelerate head wear.

#### Ⓢ PHONES Volume Control

This control adjusts the output volume for the headphones.

#### Ⓢ PHONES Jack (Tip-Ring-Sleeve)

Connect 8-ohm stereo headphones to this jack to monitor recordings or to listen to a tape directly without the use of an amplifier. Maximum output is 100 milliwatts into 8-ohm stereo headphones.

"Mono" headphones are not compatible with this circuit. So check the plug before inserting to make sure that it has 3 sections. It would also be prudent to unthread the connector and check the wiring to make sure that the two audio leads have not been jointed to make a stereo headphones into a mono set.

#### Ⓢ MIC Input Jacks (2 Conductor, Transformerless, Unbalanced)

One input for each channel of the recorder. Without the use of the "pad" (ATT switch), the maximum input signal is -23 dB, 71 mVolt. With "pad" (ATT switch depressed) max input becomes -3 dB, 700 mVolt. The input impedance of this circuit is 10k ohms, and will correctly couple to mics having impedances from 200 to 10,000 ohms. Mics rated lower than 200 ohms will work, but their output will be lower than "spec" due to the mismatch in coupling. When 3 wire balanced mics are used, we recommend the use of an input transformer.

#### Ⓢ INPUT SELECT LED Indicators

Indicates which INPUT SELECT buttons have been activated.

LINE LED : Yellow

MIC LED : Yellow

ATT LED : Yellow

#### Ⓢ INPUT SELECT Buttons (L, R)

LINE — Selects line input source signals.

MIC — Selects microphone signals.

ATT — Discards 20 dB worth of signal. The loss is useful when very loud sounds cause too high a value of electrical

energy to be generated by the microphones.  
This ATT button affects the MIC circuit only.

#### ① VU Meters

0 VU = .3 Volt. What signal will be shown on the meters will depend on the settings of the OUTPUT SELECT buttons. For a comprehensive list of the possible meter logic, see item 24, OUTPUT SELECT buttons.

#### ② FUNCTION LED Indicators

Indicates which FUNCTION buttons have been activated.

#### ③ FUNCTION (L, R) Buttons

Determines the record/reproduce status of the corresponding channels.

Up — Safe, reproduce or source determined by OUTPUT SELECT buttons.

Down — Ready to record. If "Record" has been selected through the transport controls, depressing this button will begin recording immediately. Output of recorder switches to source.

#### ④ INPUT Level Controls

For adjusting the MIC or LINE level signal. Setting has no effect on reproduce. This control is of a dual concentric type, so either channel can be adjusted independently.

#### ⑤ OUTPUT Level Controls

For adjusting the levels of the signals sent to the OUTPUT (L & R) terminals. This control is of a dual concentric type, so either channel can be adjusted independently. Use this control to set optimum monitoring or listening levels.

#### ⑥ OUTPUT SELECT Buttons

Select which of three possible sources to feed the output jacks (rear panel) and VU meter circuits. The LED's above the buttons show selection.

**INPUT** — Meter reads line input to recorder, input signal appears at output jacks. Tape signal will not be heard.

**SYNC** — Used for all normal operations, recording, sync/reproduce and reproduce. Meter reads input or head # 2 play output depending on setting of function buttons (L or/and R).

**REPRO** — Selects head # 3. Meter now reads tape playback. Does not prevent recording on head # 2. Used in

to check performance and record/play monitoring of tape.

#### ⑦ OUTPUT SELECT LED Indicators

Indicates which OUTPUT SELECT buttons have been activated.

INPUT LED : Red

SYNC LED : Yellow

REPRO LED : Green

#### ⑧ Transport Controls

This group of buttons control the mechanical action of the transport, and the in/out switching of the record circuit. The RC-71 remote control unit (see rear panel for the connection point) will duplicate this control group. When the remote is connected, both sets of controls will be active at the same time.

##### (▶) Play Button

1. When depressed alone, the tape will advance at the speed selected by the # 10 SPEED switch and the # 12 PITCH CONTROL.

2. When depressed along with the RECORD button, any or all tracks that have their FUNCTION select buttons IN (record ready) will begin recording immediately.

3. This transport has a motion sensing circuit that allows the selection of PLAY directly from either fast forward or rewind. Press PLAY when fast winding and the transport will slow, come briefly to STOP and then enter PLAY by itself.

##### (▶▶) Fast Forward Button

##### (◀◀) Rewind Button

Rewind time is 90 seconds for a 10-1/2" reel, 1-1/2 mil tape.

##### STOP Button

##### RECORD Button

Depressing this button by itself will have no effect. To begin recording, several conditions must first be met.

1. One or more FUNCTION select buttons must be IN (record ready)

2. To enable the record logic, the PLAY button must be depressed simultaneously with the RECORD button. If the transport is in PLAY, press BOTH buttons together and the unit will go into record mode.

3. Since the PAUSE button can hold the record logic in an active condition (see next page, PAUSE button) if PAUSE is active, recording can start with a one button PLAY command.

4. Since depressing PLAY/RECORD will enable the record logic when the FUNCTION select buttons are NOT active, it is possible to begin recording with this sequence as well as the more usual ones. Do this;

1. Establish the record active condition by depressing PLAY and RECORD together, then—  
 2. Depress one or both FUNCTION select buttons and recording will commence. This additional logic is provided when it is necessary to hear a previously recorded signal up to the "punch-in" point. If the FUNCTION select buttons are OUT (safe) the tape signal CAN appear at the output. If the FUNCTION buttons are IN (record ready) only new INPUT signal can be auditioned and listening to the tape to find a "Cue" point for the punch-in will not be possible. When you must listen to the tape, pre-load the record logic and use the FUNCTION buttons to begin the recording.

#### PAUSE Button

This button will stop the tape and the recording process without disengaging the record logic, to continue recording, just press the play (▶) button alone. If a RECORD/PAUSE logic condition is in effect, allowing this "one key" return to record mode, the green and red LEDs above the PAUSE and RECORD buttons will light.

#### RECORD Status Indicator

The red LED lights up when the deck has been set into the record mode and begins blinking if the FUNCTION buttons are not depressed.

#### PAUSE Status Indicator

The green LED lights only when PAUSE and RECORD have been simultaneously pressed.

#### Shut Off Arm

The shut off arm will drop power to the capstan and reel motors if the tape breaks. It's a good idea to allow it to drop when you take a break in the middle of a session. Doing this will stop the constant rotation of the capstan, and will lengthen the life of the capstan motor bearings. It is not necessary to unthread the tape. Just allow it to become slack so that the shut off arm can drop.

#### Pinch Roller

#### Capstan Shaft

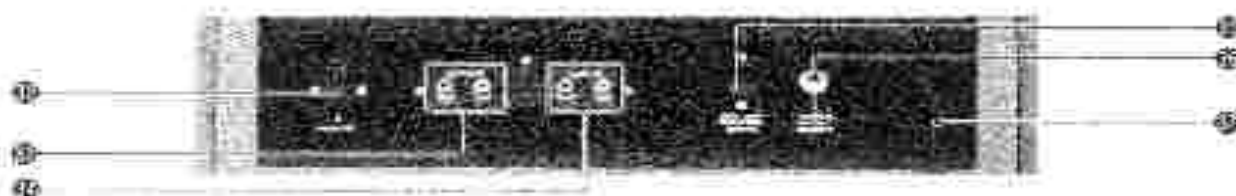

### BACK PANEL

#### REMOTE Connector

Allows connection of the optional RC-71 Remote Control Unit.

#### Output Jacks

Output level is -10 dB (0.3 V). Minimum load impedance is 10k ohms (unbalanced).

#### LINE IN Jacks

Input level is -10 dB (0.3 V). Input impedance is 50k ohms (unbalanced).

#### DBX UNIT CONTROL SIGNAL Connector

This allows connection of the SYSTEM DX-2D NOISE REDUCTION SYSTEM and supplies control signal to the dbx system to permit simultaneous encode/decode dbx operation. Because of this "dual process", no switching is required when you change function from recording to playback. The fact that there are separate sections for each

function will also allow "off the tape" monitoring when the dbx is used.

#### PUNCH IN/OUT REMOTE Connector (RC-30P)

Allows connection of the optional RC-30P TASCAM PUNCH IN/OUT REMOTE PEDAL.

#### AC Cord

#### \*INPUT and OUTPUT levels

If you do not have access to any test equipment or test tapes, a good working position for the output controls would be position "7". From that position, careful monitoring and experimentation will help you determine the optimum setting. The loudest peaks may briefly register in the red zone, but the input levels should be reduced if the deflection needles seem to spend a lot of time in the red zone. For information on setting the correct input and output levels, see "Calibration" on page 29.



## BASIC INFORMATION

### Reel Installation

#### Small Hub Reels

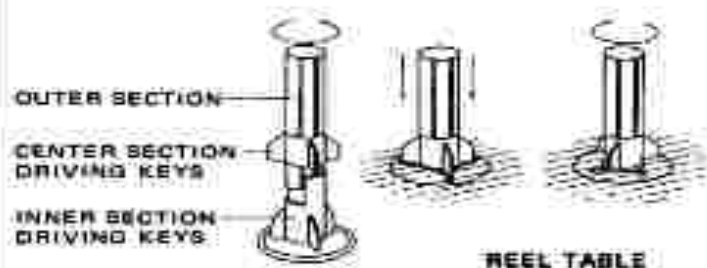

#### Large Hub Reels

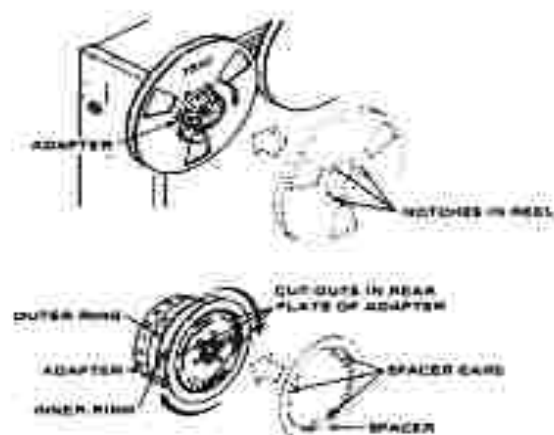

### NOTE:

A metal spacer is mounted on the back of the reel adaptors and it must be in place when the NAB standard 10-1/2" metal reels are used.

### Head Configuration

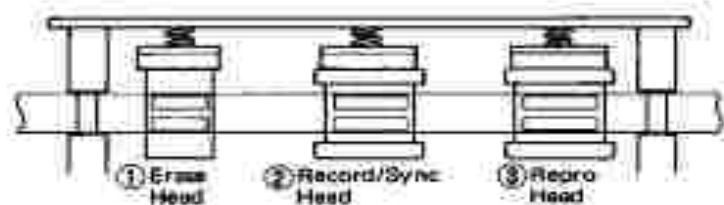

### Threading the Tape

Lift the head access cover and release the sync head shield to gain access for threading.

### NOTE:

If you use a reel of tape that has been stored "tailed out" (See "Editing and Tape Storage"), it must be placed on the right reel table and re-wound to the left.



### Erasing the Tape

A previously recorded tape is automatically erased when you make a new recording on it. For the best-quality recordings, and for convenience, we recommend the TEAC E-2A bulk eraser. This will erase your tapes cleanly in one pass for the best signal-to-noise ratio. Another way to erase is to record with the input controls set to the minimum levels.

### Editing and Tape Storage

Never use ordinary adhesive tape for this vital procedure. Use only the special tape made exclusively for tape editing.

Monitor with the CUE lever. When you have located the precise point to make the cut, stop the tape and mark the back of the tape with a Chisacraft type pencil at the center of the reproduce head, and then use the EDIT switch. With the EDIT switch and (▶) button depressed, the tape will begin unthreading itself (dumping) because the take up reel will not be moving to take up the slack. The use of non-magnetic tools is highly recommended. A good quality machine-milled tape-editing block will help ensure good edits.

Tape should be stored in a cool, dry place well away from the influence of magnetic fields. Print-through (the unwanted transfer of magnetic signals from one part of the tape to an adjacent part of the tape, causing "echos") may be reduced by winding (NOT fast winding) the tape onto the take up reel at normal playing speed for storage. When the tape is played again, it is first rewound at a high speed onto the supply reel. This is called storing the tape "tails out" and is a common practice in many studios. A helpful idea is to use white leader tape at the beginning and red leader tape at the tail end. The analogy with vehicle head and tail lights is then an easy way to remember which end is which.

## ENTERING "RECORD"

In any tape recorder that offers "SYNC" or overdub capabilities (where a new part may be added to an already recorded part), many different methods for entering the record mode will be necessary. On the 32, there are four ways to cause the transport to begin recording. Although all of these different methods can be inferred by reading the descriptions that list the action of each group of controls, we'll review all four methods here. The title of each method is the LAST action you perform to make the process start.

1. **PLAY/RECORD.** Depress these two buttons together. Of course, a signal source must be selected (MIC, MIC ATT or LINE), and one or more FUNCTION select buttons must be depressed. This industry standard two button (interlock) method can be used for almost all recordings, but it has a drawback. The minute that you depress a FUNCTION select button, that track is switched to "source" and you can't hear a signal that is already on the tape, even if you press PLAY all by itself. If you don't need to hear the previously recorded signal to find the right place to begin your new part, this method is OK. If you must hear, use method 2.
2. **FUNCTION select.** To use this method, switch the OUTPUT SELECT to SYNC, select a signal source and with all FUNCTION select buttons UP (inactive), press PLAY/RECORD together, this action will start the tape playing without actually recording. It WILL pre-load the record logic. It will NOT switch the output electronics to "source" (new signal instead of tape playback). You will still be able to hear the tape. When you hear the cue, depress the FUNCTION select button(s) and recording will commence.
3. **PLAY.** A single button return to the record mode is possible if a RECORD/PAUSE logic has been previously selected, see the paragraph on the PAUSE control on page 7 for a complete description of this logic. This method is useful when you wish to stop recording, wait for some undesired part to finish and then continue recording.

4. **REMOTE PEDAL RC-30P.** An accessory pedal is available that will allow you to start recording with a foot switch. This is extremely useful to the musician who must make a "tight" punch-in that requires both hands "on the instrument" at the exact moment of the "punch". The foot switch will NOT start the transport, you must do that, but it WILL start and stop recording. Here's How.

Connect the TASCAM PUNCH IN/OUT REMOTE PEDAL to the rear of the 32. Now, even with both of your hands occupied, PUNCH OUT can still be performed by using the remote pedal. While in sync reproduce, pressing the pedal with your foot initiates punch-in of the channels for which record function has been selected. Punch-out is done by simply pressing the pedal again.

To conclude this section on entering record, here is a review of all the record related controls and what they do.

**INPUT SELECT BUTTONS:** The signal coming from MIC or LINE is controlled by the INPUT SELECT buttons.

**LINE** — Selects line input source signals.

**MIC** — Selects microphone signals.

**ATT** — Discards 20 dB of signal from the microphones.

**OUTPUT SELECT BUTTONS:** The signal presented at the output terminals is controlled by the OUTPUT SELECT buttons.

**INPUT** — will typically be used for source calibrations during system interface and set-up procedures. When this button is depressed, the input signals are sent directly to the output terminals.

**REPRO** — will present the reproduce head signal to the output jacks to monitor the printed signal on the tape for reference during recording.

**SYNC** — will be used for most operations: recording, overdubbing (sync), and reproduce. The monitoring status is then determined by the FUNCTION buttons.

**FUNCTION BUTTONS:** When the OUTPUT SELECT is in either the INPUT or REPRO position, the FUNCTION buttons have the single purpose of determining the record status. UP is safe. DOWN is ready-to-record.

When the OUTPUT SELECT is in the SYNC position, the FUNCTION buttons serve two purposes:

- 1) they determine the record status — UP is safe, DOWN is ready-to-record.
- 2) they determine the monitoring status — UP is sync/tape reproduce, DOWN is source.

## VOLTAGE CONVERSION

This deck is adjusted to operate on the electric voltage specified on the reel tag and packing carton.

**Note:** This voltage conversion is not possible on models sold in the U.S.A., Canada, UK, Australia or Europe.

For general export units, if it is necessary to change the voltage requirements of this deck to match your area, use the following procedures. Always disconnect power line cord before making these changes.

1. Disconnect the power cord of the deck from the source.
2. Remove the bonnet panel and locate the voltage selector on the side of the deck. Refer to "2-2 Removing the Panels of the Deck" on page 78.
3. To increase the selected voltage, turn the slotted center post clockwise using a screw driver or another suitable tool.
4. To decrease the selected voltage, turn the slotted center post counter-clockwise.
5. The numerals that appear in the cut-out window of the voltage selector indicate the selected voltage.
6. If the desired voltage numerals do not appear in the cut-out window as you turn the slotted center post, your deck must be taken to an authorized TEAC Service Facility for voltage conversion.

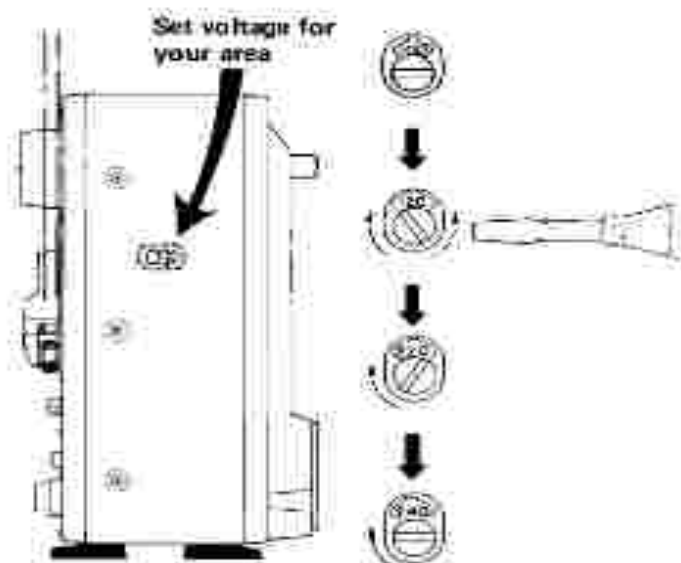

## NOTE FOR U.K. CUSTOMERS

### U.K. Customers Only:

Due to the variety of plugs being used in the U.K., this unit is sold without an AC plug. Please request your dealer to install the correct plug to match the mains power outlet where your unit will be used as per these instructions.

### IMPORTANT

The wires in this mains lead are coloured in accordance with the following code:

**BLUE:            NEUTRAL**  
**BROWN:        LIVE**

As the colours of the wires in the mains lead of this apparatus may not correspond with the coloured markings identifying the terminals of your plug, proceed as follows:

The wire which is coloured BLUE must be connected to the terminal which is marked with the letter N or coloured BLACK. The wire which is coloured BROWN must be connected to the terminal which is marked with the letter L or coloured RED.

THE APPLIANCE CONFORMS WITH EEC DIRECTIVE 87/308/EEC REGARDING INTERFERENCE SUPPRESSION

CONFORME AL D.M. 13 APRILE 1989  
DIRETTIVA CEE/87/308

### Bescheinigung des Herstellers/Importeurs

Hiermit wird bescheinigt, daß beachtet ist:

**MAGNETTONBANDGERÄT TASCAM 32**

gemäß der Bauartbeschreibung

in Übereinstimmung mit den Bestimmungen der

**AMTSBLATT 163/1984, VFG 1045/1984**

Werkzeugmaschinen

hergestellt ist.

Der Deutschen Bundespost wurde das Inverkehrbringen dieses Gerätes angezeigt und die Berechtigung zur Überprüfung der Seite auf Einhaltung der Bestimmungen eingetragt.

**TEAC CORPORATION**

Werk 200 1000000000000000

## CONNECTION AND OPERATION OF THE DX-2D



The DX-2D is a 2-channel dbx system designed for integration with the 32 Recorder/Reproducer.

**Note:** When the DX-2D is used together with the 32, encoded signal levels displayed on VU meters will be found to be of slightly less value (through compression) than non-encoded signal levels.

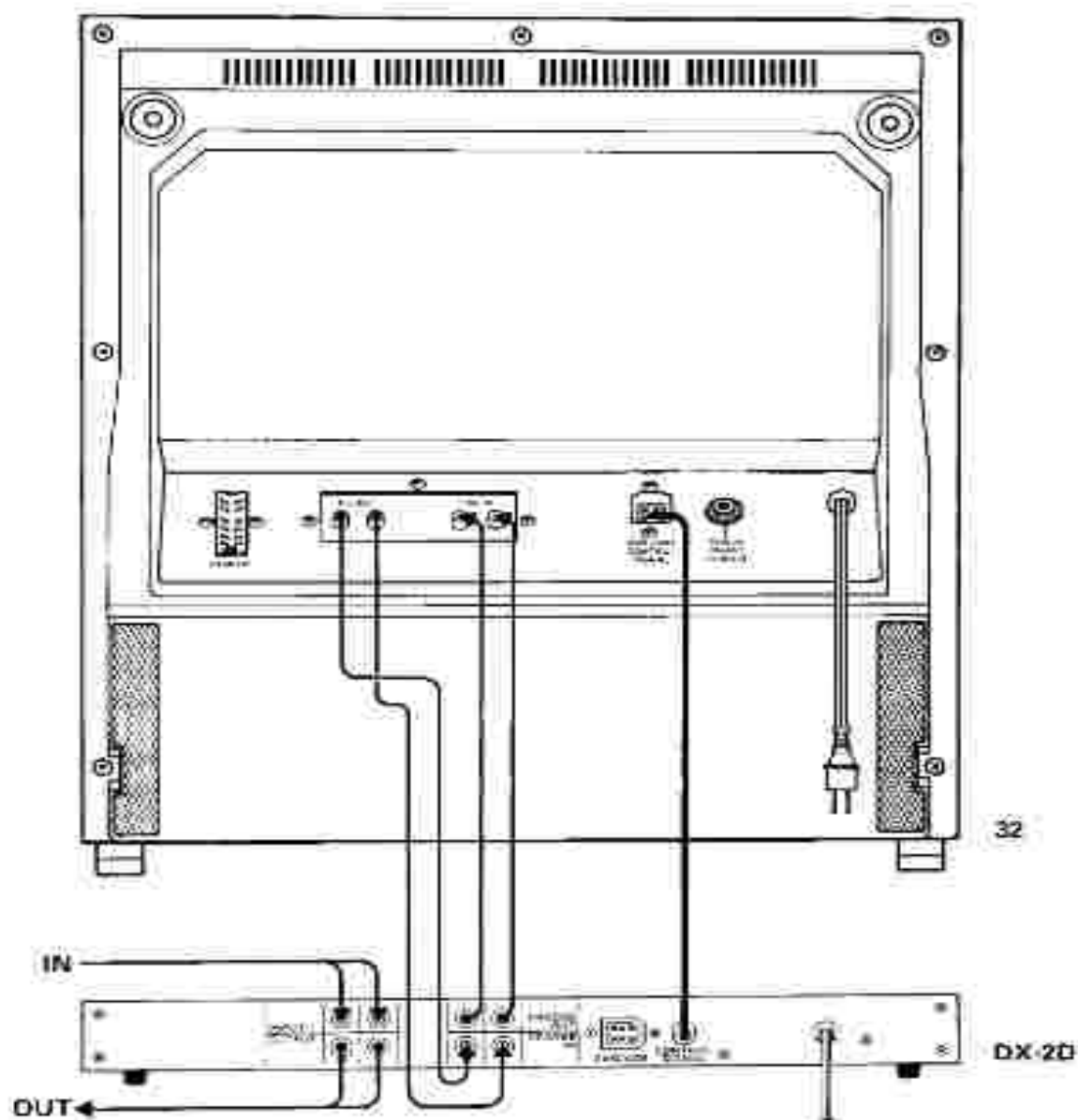

### DBX Bypass Switch

1. With this DBX NOISE REDUCTION SYSTEM both ENCODE/DECODE are in operation while this switch is in the (  $\square$  DBX) position. With this switch in the (  $\equiv$  BYPASS) position, the DBX circuit is bypassed, which deactivates the ENCODE/DECODE function. The switches for each channel (1 - 2) work independently to facilitate separate functioning.
2. With this switch in the (  $\equiv$  BYPASS) position, the LED cuts off, and the DBX circuit is bypassed. Keep this switch in this position when not using the DBX NOISE REDUCTION SYSTEM.

### How the DX-2D functions

The DX-2D functions only when connected to the DBX UNIT CONTROL SIGNAL terminal of the 32.

Once the DX-2D has been connected, you may virtually ignore it. The unit is completely automatic. And, because of the design and nature of this noise reduction system, there is no need for record or reproduce level match adjustments — the level is non-critical within nominal tolerances; the circuit is stable.

Since decode and encode functions are actuated by the respective channels of the DX-2D, simultaneous dbx NR Encoding/Decoding is possible without having to switch between ENCODE or DECODE.

### Original Recording

Suppose you are going to record, with OUTPUT SELECT in the SYNC position, depress FUNCTION select buttons 1 and/or 2. LED indicators will light, signaling ready to record.

An encoded signal will be automatically reproduced when the 32 is started because of the DX-2D's ability to simultaneously encode and decode while the DBX switch is in the (  $\square$  DBX) position.

### HOW THE DX-2D WORKS

The DX-2D is a wide-band compression-expansion system which provides a net noise reduction (broadband, not just hiss) of a little more than 30 dB. In addition, the compression during recording permits a net gain in tape headroom of about 10 dB.

A compression factor of 2:1 is used before recording; then, 1:2 expansion on reproduce. These

compression and expansion factors are linear in decibels and allow the system to produce tape recordings with over a 100 dB dynamic range — an important feature, especially when you're making live recordings. The DX-2D employs RMS level sensors to eliminate compressor-expander tracking errors due to phase shifts in the tape recorder, and provides excellent transient tracking capabilities.

To achieve a large reduction in audible tape hiss, without danger of overload or high frequency self-erasure on the tape, frequency pre-emphasis and de-emphasis are added to the signal and RMS level sensors.

If you're an electronic engineer, all of the above gab may tell you the whole story of what's going on in the DX-2D, but if you're not, to make things a little easier to understand we'll ask you to use your imagination.

Imagine four little recording engineers in the box with each of their hands on a volume control. They are incredibly fast but very stupid, so you must give them a set of rules. You tell them to raise signals that are below "0 VU", and reduce signals that are higher than "0 VU".

The lower the signal is, the more they raise it, and the higher levels above "0 VU" get lowered more and more as they go up in level past "0".

This is the 2:1 compression. You also tell them to call "0.316 V" "0 VU". Here they do nothing, no change except frequency pre-emphasis or boost. Since you know they are going to keep the high levels under control, you can raise the "top end" a bit and still not overload the tape. Just to keep it simple for them, the boost in highs is fixed. They put it in all the time, no matter what level changes they are making. Now we play tape back, and say OK, do everything backwards. Levels above "0.316 V" "0 VU" are raised and levels below "0.316 V" are lowered, and while you're at it, fellows, take off the extra top end as well. Follow the rules in reverse. As long as you don't confuse them by shifting the "0 VU" point, they work just great, but — don't put in more than "0.316 V" as zero VU, and don't make the tape playback zero anything other than "0.316 V" either. As we said they're very dumb and will follow instructions very precisely. Differing levels will produce decoding errors.

The reason these errors may not be objectionable is that people could have played or sung or whatever with a little more or less dynamics. A small change won't be as noticeable as a mistake, but it is not perfect. The tolerance here is not electronic, it's human. To get exactly what you put in, it is necessary to get an exact "0 VU", 0.316 V in and out. The system is level sensitive although it is realistic to say it is "artistically" forgiving.

One common mistake we find, is that people don't check the OUTPUT voltage of the mixer or other device feeding the DX-2D, and don't remember that the DX-2D is the first item in the system (32/DX-2D). "Breathing" and "pumping" can result especially on instruments like piano and acoustic guitars, if the levels are seriously mismatched, because of the way the DX-2D works. If your mixer "0" VU is not 0.3 volt, (the DX-2D "standard zero") the code process will reflect the fact that all levels are higher (if the mixer "zero" is 1 volt.) Now, when you DECODE, the troubles start. The 32 playback electronics cannot safely be set to this "high" output level, and the decoder will not "see" the same levels in playback. Decode errors will occur.

Consider also the fact that the DX-2D will increase your signal to noise ratio by 30 dB. If you record at a generally lower level you will avoid dbx problems and still have quiet tapes. Try using -5 or -7 VU as a "zero".

### **Mixing**

Program material must be in uncompressed form for mixing and sound-on-sound recording. You must first decode the program material which has been encoded by the DX-2D in order to mix it with any other material - compressed or uncompressed. Of course, mixed material may be compressed again for recording. If this precaution is not followed, you'll get cross-modulation of the separate signals or tracks.

The little guys in the box will look at their "chart" and give you some really entertaining level shifts, as we have said, they're fast but dumb.

### **Subsonics and Interference**

The DX-2D incorporates an effective bandpass filter with -3 dB response at 20 Hz and 30 kHz. This filter suppresses undesirable sub- and super-sonic frequencies to keep them from introducing errors into the encode or decode process. However, if rumble from trains or trucks is picked up by your microphone and fed to the DX-2D - filters are not perfect - modulation of the program material during low level passages may occur. This low frequency component will not itself be passed through the recorder and so, will not be present at reproduce for proper decoding. If this low level decoding error is encountered, and subsonics are suspected, we suggest the addition of a suitable high pass filter ahead of the DX-2D and after the mic preamplifier for further attenuation of these subsonic frequencies.

## M-30 RECORDING MIXER

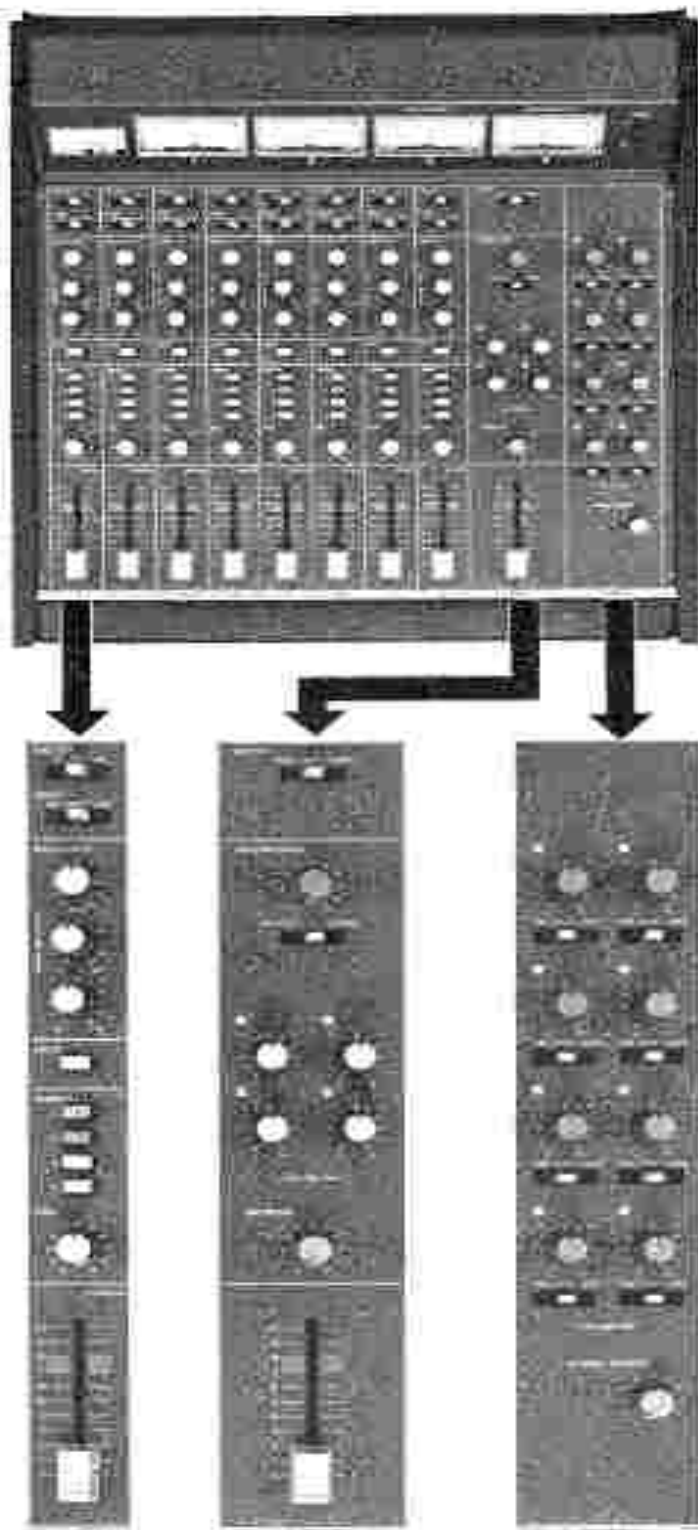

The M-30, a multi-function recording mixer, not only offers multi-microphone recordings, mixing and equalization functions, but also offers the possibility to draw out any desired signal throughout sound processing, and the ability to mixdown to obtain a master tape on a 2-track tape deck.

We recommend the TASCAM M-30 RECORDING MIXER as the ideal partner for the 32.

### FEATURES

#### INPUT SECTION

- 8 mic inputs (6 low impedance balanced, and 2 high impedance unbalanced mic inputs)
- 8 tape inputs
- 8 line inputs
- Mic/line/remix(tape) input selector
- Mic ATT (0/20/40)
- 2 band parametric equalizer (60 – 1.5 k, 1 k – 10 kHz plus 12.5 kHz shelving type equalizer ( $\pm 15$  dB))
- Mute switches
- Direct out
- Cue out
- Accessory send/receive for each input
- Overload indicator for each input
- Buss assign buttons and pan pots

#### MASTER SECTION

- 4 main program mixing busses
- Buss input for each buss
- Accessory send/receive for each buss
- 4 buss out (line out)
- Monitor gain and pan controls for each program buss
- Master fader
- Meter input selector (buss/monitor/submix)
- Stereo monitor headphones with volume control and input selector (monitor/submix)

#### SUBMIX SECTION

- 8 x 2 submixer
- Pre/post/tape input selector
- Gain and pan controls
- Submix master gain control
- Stereo submix out
- Stereo submix in

#### OTHERS

- 2 sets of stereo phono in/out terminals (built in phono RIAA EQ)



## SPECIFICATIONS

### 8-Input/4-Line Output/2 Monitor Output/2-Submix Output

#### Input Selector

1 – 6 channel:	MIC (Low impedance)/ REMIX/LINE
7, 8 channel:	MIC (High impedance)/ REMIX/LINE

#### Mic Input (Low impedance) – channel 1 – 6:

Mic impedance:	200 to 600 ohms nominal mics [matched for mics of 600 ohms or less]
Input impedance:	600 ohms, balanced XLR type
Nominal input level:	-60 dBV (1 mV)
Maximum input level:	+10 dBV (3 V) – ATT to 40 dB

#### Mic Input (High impedance) – channel 7, 8:

Mic impedance:	10k ohms nominal mics
Input impedance:	100k ohms
Nominal input level:	-60 dBV (1 mV)
Maximum input level:	+10 dBV (3 V) – ATT to 40 dB

#### Line Input

Input impedance:	20k ohms
Nominal input level:	-10 dBV (0.3 V)
Maximum input level:	+14 dBV (5 V)

#### Tape Input:

Input impedance:	50k ohms
Nominal input level:	-10 dBV (0.3 V)
Maximum input level:	+14 dBV (5 V)

#### Line Output:

Minimum load impedance:	5k ohms
Nominal load impedance:	10k ohms
Nominal output level:	-10 dBV (0.3 V)
Maximum output level:	+14 dBV (5 V)

#### Monitor Output:

Minimum load impedance:	5k ohms
Nominal load impedance:	10k ohms
Nominal output level:	-2.2 dBV (0.775 V)
Maximum output level:	+14 dBV (5 V)

#### Submix Output:

Minimum load impedance:	5k ohms
Nominal load impedance:	10k ohms
Nominal output level:	-10 dBV (0.3 V)
Maximum output level:	+14 dBV (5 V)

#### Cue Output:

Minimum load impedance:	5k ohms
Nominal load impedance:	10k ohms
Nominal output level:	-10 dBV (0.3 V)

#### Direct Output:

Minimum load impedance:	5k ohms
Nominal load impedance:	10k ohms
Nominal output level:	-10 dBV (0.3 V)

#### ACCESS SEND Output (Input/Master Section):

Minimum load impedance:	5k ohms
Nominal load impedance:	10k ohms
Nominal output level:	-10 dBV (0.3 V)

#### ACCESS Receive Input (Input/Master Section):

Input impedance:	200k ohms
Nominal input level:	-10 dBV (0.3 V)
Minimum input level:	-18 dBV (0.13 V)

### Submix input – channel L,R (and PRE, POST, TAPE 1 – 8):

Input impedance:	10k ohms
Nominal input level:	-10 dBV (0.3 V)
Maximum input level:	+14 dBV (5 V)

#### Buss Input:

Input impedance:	10k ohms
Nominal input level:	-10 dBV (0.3 V)
Maximum input level:	+14 dBV (5 V)

#### Headphones Output:

Load impedance:	8 ohms
Maximum output power:	Greater than 100 mW – Output VR at max.

#### Phono Input:

Input impedance:	45k ohms
Nominal input level:	-54 dBV (2 mV) at 1 kHz
Minimum input level:	-60 dBV (1 mV) at 1 kHz
Maximum input level:	-30 dBV (31.6 mV) at 1 kHz

#### Phono Output:

Minimum load impedance:	5k ohms
Nominal load impedance:	10k ohms
Nominal output level:	-10 dBV (0.3 V) at 1 kHz

#### Frequency Response:

Line output:	30 to 20,000 Hz, ±2 dB
Monitor output:	30 to 20,000 Hz, ±2 dB
Submix output:	30 to 20,000 Hz, ±2 dB

#### Equalizer:

Type:	Peak Parametric and Shelving
Level:	±15 dB
Frequency, low:	60 to 1,500 Hz
Mid:	1,000 to 10,000 Hz
High:	12,500 Hz

#### Signal to Noise Ratio (A weighted/unweighted)

Equivalent Mic (Low impedance):	116 dB WTD 114 dB UNWTD (20 to 20,000 Hz)
---------------------------------	--

#### Mic (Low impedance)

1 channel:	Better than 66/64 dB
6 channel:	Better than 57/55 dB

#### Mic (High impedance)

1 channel:	Better than 58/57 dB
2 channel:	Better than 55/53 dB

#### Mic (Low and high impedance) 5 channel:

Better than 53/51 dB
----------------------

#### Phono input to

phono output:	Better than 57 dB UNWTD (20 to 20,000 Hz)
---------------	--

#### Cross Talk:

Better than 60 dB (1 kHz, Nominal input level)
---

#### Total Harmonic Distortion:

Less than 0.1 % at 1 kHz, Nominal input level
--

#### Fader Attenuation:

Overload Indicator Level:	25 dB above nominal input level
Peak Indicator Level:	10 dB above nominal output level

#### Dimensions (WxHxD):

465 x 160 x 520 mm (18-1/4" x 6-5/16" x 20-1/2")
---

#### Weight:

16 kg (35-5/16 lbs.)
----------------------

#### Power Requirement:

100/120/220/240 V AC, 50/60 Hz, 26 W (General Export Model)
120 V AC, 60 Hz, 26 W (U.S.A./Canada Model)
220 V AC, 50 Hz, 26 W (Europe Model)
240 V AC, 50 Hz, 26 W (UK/AUS Model)

## ACCESSORY INFORMATION

### TO-122A Test Tone Oscillator

Checks input/output balance or other electric characteristics of the system chain. This unit is also useful for tape deck maintenance work.

\*Output pin jack

\*Output level -10 dB, -40 dB (0 dB/1 V)

\*Selectable frequencies 40 Hz, 400 Hz,  
1 kHz, 4 kHz, 10 kHz,  
15 kHz



### E-3 Head Demagnetizer



### E-2A Bulk Eraser



### RE-1004 Reel (10-1/2", 1/4" tape)

### RE-712 Reel (7", 1/4" tape)



### PB-64 Patch Bay

A tangle of cables is one of the growing vexations of any audio system. With all of the inputs and outputs plugged into the rear panel, jumper cables plugged into the front make any hookup you need neatly.



### RC-71 Remote Control Unit



### RC-30P Punch In/Out Remote Pedal



### RM-300 Rack Mount Angle (EIA 19-inch)

The RM-300 is a rack mounting angle-kit for the TASCAM recorder/reproducer 32 to enable mounting in the CS-607 or a standard 19-inch rack.



#### **CS-607 Console Rack (EIA 19-inch)**

The CS-607 is a standard 19-inch console rack to be used with the RM-300 for mounting of the TASCAM 32.



#### **T-0804 Blank Panel (EIA 19-inch)**

The T-0804 is designed to cover up the unavoidable blank spaces on the TASCAM CS 607 or equivalent EIA standard 19-inch rack.

#### **Professional Low Loss Cable**

There are vast differences in cable design and performance, and those differences can make or break an otherwise excellent sound system. When you're investing in the kind of high quality audio equipment represented by the TASCAM Studio Series, it makes sense to use TASCAM professional audio cables. Anyone who's switched to them will tell you they're worth every cent.

#### **LOW CAPACITANCE**

Our cables feature very low capacitance under 15 picofarads per foot, so they don't act as high-frequency roll-off filters as do typical cables of 100 or 300 pF/foot. In addition, our cables use an ultra-high density bare-copper braided shield (99 % coverage), so electrostatic noise (buzz or hum) and RFI (CB or broadcast signals) are kept out of your program.

Low capacitance is important, and so is consistent capacitance; that is, you want the electrical coupling of center conductor-to-shield to remain the same throughout the cable, even if it is sharply bent, crushed, flexed, or tugged. Should the local cable capacitance change, noise and/or signal losses often result. We utilize the unique dielectric known as Datalene. This special insulation keeps the stranded signal conductor perfectly centered within the shield. Datalene is about as flexible as foam core dielectrics but far more resistant to extreme heat or cold, and it has a "memory", so it retains its shape after flexing. Datalene also acts as a mechanical shock absorber, guarding against external impacts which, in other cables, might sever the center conductors and cause intermittent contact.

When we join the connector to the cable, we insert the cable's stranded center conductor all the way into the pin and then fill the pin with solder. The braid is wrapped and soldered a full 120° around the shell, not tacked at one spot, so you get maximum shielding and strength.

## SPECIFICATIONS OF THE 32

### MECHANICAL

<b>Tape:</b>	1/4 inch, 1-1/2 mil, low noise, high output tape
<b>Track Format:</b>	2-track, 2-channel, track width, NAB 0.079 inch (2.0 mm), DIN 2.7 mm
<b>Reel Size:</b>	10-1/2" NAB (large) hub maximum
<b>Tape Speeds:</b>	15 inches per second (38 cm/sec.), 7-1/2 inches per second (19 cm/sec.); Variable, $\pm 12\%$ relative to 15 ips/7-1/2 ips
<b>Speed Accuracy:<sup>1)</sup></b>	$\pm 0.8\%$ deviation
<b>Wow and Flutter:<sup>1)</sup></b>	
<b>15 ips</b>	$\pm 0.06\%$ peak (DIN/IEC/ANSI weighted) $\pm 0.1\%$ peak (DIN/IEC/ANSI unweighted) 0.05% RMS (JIS/NAB weighted) 0.07% RMS (JIS/NAB unweighted)
<b>7-1/2 ips</b>	$\pm 0.09\%$ peak (DIN/IEC/ANSI weighted) $\pm 0.12\%$ peak (DIN/IEC/ANSI unweighted) 0.07% RMS (JIS/NAB weighted) 0.09% RMS (JIS/NAB unweighted)
<b>Fast Wind Time:</b>	90 seconds for 10-1/2" reel, 2,400 feet
<b>Start Time:</b>	Less than 0.8 sec. to reach standard Wow and Flutter
<b>Capstan Motor:</b>	FG (frequency generator) DC servo motor
<b>Reel Motors:</b>	2-slotless DC motors
<b>Head Configuration:</b>	3 heads; erase, record/reproduce x 2
<b>Tape Cue:</b>	Manual
<b>Motion Sensing:</b>	0.8 sec. $\pm 0.15$ sec. delay time, stop to next motion
<b>Dimensions:</b>	(W) 18-3/16" x (H) 18-3/16" x (D) 10-1/8" (410 x 481 x 258 mm)
<b>Weight:</b>	44.1 lbs (20 kg), net

### ELECTRICAL

<b>Input Selector:</b>	Line/Mic/Mic ATT (20 dB)
<b>Line Input:</b>	
<b>Input impedance:</b>	50k ohms, unbalanced
<b>Maximum source impedance:</b>	2.5k ohms
<b>Nominal input level:</b>	-10 dBV (0.3 V)
<b>Maximum input level:</b>	+18 dBV (8.0 V)
<b>Mic Input:</b>	
<b>Source impedance:</b>	10k ohms or less
<b>Input impedance:</b>	10k ohms, unbalanced
<b>Nominal input level:</b>	-60 dBV (1 mV)
<b>Maximum input level:</b>	-3 dBV (700 mV), with mic ATT (20 dB) engaged
<b>Line Output:</b>	
<b>Output impedance:</b>	1 k ohms, unbalanced
<b>Minimum load impedance:</b>	10 kohms
<b>Nominal load impedance:</b>	50 k ohms
<b>Nominal output level:</b>	-10 dBV (0.3 V)
<b>Maximum output level:</b>	+18 dB (8.0 V)
<b>Headphone output:</b>	100 mW maximum at 8 ohms stereo headphones
<b>Bias Frequency:</b>	150 kHz
<b>Equalization:</b>	NAB (USA/Canada/General Export models): 3180 + 50 $\mu$ sec. at 15 ips (38 cm/sec.), 7-1/2 ips (19 cm/sec.) IEC-1 (Europe/U.K./Australia models): $\infty$ + 35 $\mu$ sec. at 15 ips (38 cm/sec.), $\infty$ + 70 $\mu$ sec. at 7-1/2 ips (19 cm/sec.)
<b>Record Level Calibration:</b>	0 VU reference; 250 nWb/m tape flux level
<b>Frequency Response:</b>	
<b>Record/Reproduce:<sup>3)</sup></b>	
<b>15 ips</b>	40 Hz - 22 kHz, $\pm 3$ dB at 0 VU 40 Hz - 22 kHz, $\pm 3$ dB at -10 VU
<b>7-1/2 ips</b>	40 Hz - 16 kHz, $\pm 3$ dB at 0 VU 40 Hz - 20 kHz, $\pm 3$ dB at -10 VU
<b>Sync and Reproduce:<sup>2)</sup></b>	
<b>15 ips</b>	40 Hz - 22 kHz, $\pm 3$ dB
<b>7-1/2 ips</b>	40 Hz - 20 kHz, $\pm 3$ dB
<b>Total Harmonic Distortion (THD):<sup>3)</sup></b>	0.8% at 0 VU, 1,000 Hz, 250 nWb/m 3% at 13 dB above 0 VU, 1,000 Hz, 1,116 nWb/m

**Signal-to-Noise Ratio:<sup>2)</sup>**  
 15 ips  
 7-2/2 ips

**Adjacent Channel Crosstalk (Overall):<sup>3)</sup>**  
**Erasure:<sup>3)</sup>**  
**Headroom:**  
**Connectors:**

**Line inputs and outputs:**  
**Mic input:**  
**Remote control:**  
**Punch in/out remote:**  
**dbx unit:**  
**Power Requirement:**

At a reference of 1 kHz, at 13 dB above 0 VU, 1,116 nWb/m  
 68 dB A weighted (NAB), 60 dB unweighted  
 66 dB A weighted (NAB), 58 dB unweighted  
 82 dB A weighted (NAB), with dbx\*  
 82 dB unweighted, with dbx  
 Better than 50 dB down at 1,000 Hz, 0 VU  
 Better than 65 dB at 1 kHz, +10 VU reference  
 Recording Amplifier — Better than 25 dB above 0 VU at 1 kHz.

RCA jack  
 Phone jack (Tip-Sleeve)  
 Multi-Pin jack  
 Phone jack (Tip-Sleeve)  
 Multi-Pin jack  
 100/120/220/240 V AC, 50/60 Hz, 70 W (General Export Model)  
 120 V AC, 60 Hz, 70 W (USA/Canada Model)  
 220 V AC, 50 Hz, 70 W (Europe Model)  
 240 V AC, 50 Hz, 70 W (UK/AUS Model)

In these specifications, 0 dBV is referenced to 1.0 Volt. Actual voltage levels also are given in parenthesis. To calculate the 0 dB = 0.775 Volt reference level (i.e., 0 dBm in a 600-ohm circuit) add 2.2 dB to the listed dB value; i.e., -10 dB re: 1 V = -7.8 dB re: 0.775 V.

1) Specifications were determined using TEAC Test Tape YTT-2004/YTT-2003.

2) Specifications were determined using TEAC Test Tape YTT-1004/YTT-1003 (NAB Equalization), YTT-1044/YTT-10432 (IEC Equalization)

3) Specifications were determined using TEAC Test Tape YTT-8063.

Changes in specifications and features may be made without notice obligation.

\*dbx is a trademarks of dbx, Inc.

**Options for:**

**Mounting (Standard 19 inch rack):**  
**Remote control:**  
**Punch in/out remote control:**

RM-300 Rack Mount Angle, CS-807 Console Rack and T-0804 Blank Panel  
 Full transport function available with RC-71  
 Punch in/out function available with RC-30P.

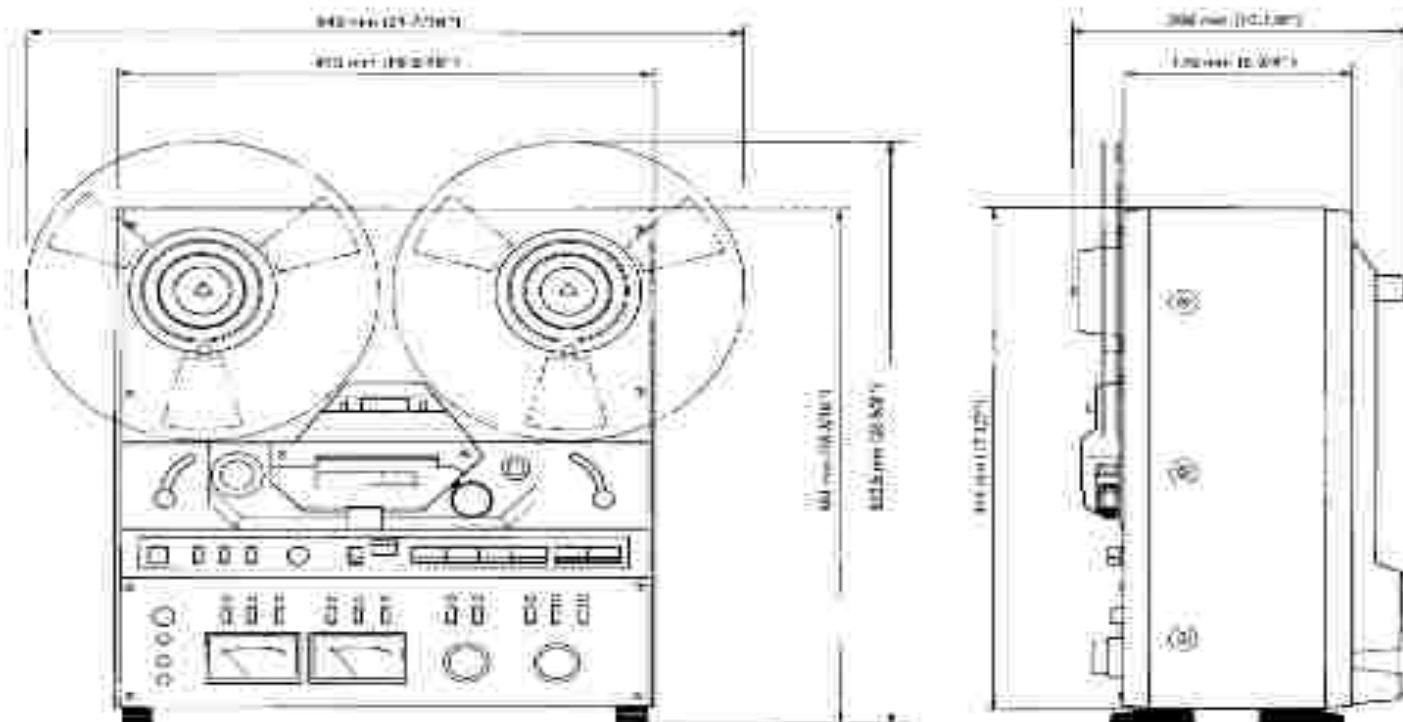

## THE dB: WHO, WHAT, WHY

No matter what happens to the signal while it is being processed, it will eventually be heard once again by a human ear. So the process of converting a sound to an electrical quantity and back to sound again must follow the logic of human hearing.

The first group of scientists and engineers to deal with the problems of understanding how the ear works were telephone company researchers, and the results of their investigations form the foundation of all the measurement systems we use in audio today. The folks at Bell Laboratories get the credit for finding out how we judge sound power, how quiet a sound an average person can hear, and almost all of the many other details about sound you must know before you can work with it successfully.

From this basic research, Bell Labs developed a system of units that could be applied to all phases of the system. Sound traveling on wires as electrical energy, sound on tape as magnetic energy, sound in air; anyplace that sound is, or has been stored as energy until some future time when it will again be sound, can be described by using the human ear-related system of numbers called "bels" named in honor of Alexander Graham Bell, the inventor of the telephone.

What is a bel and what does it stand for?

It means, very simply, twice as loud to the human ear. Twice as loud as what? An obvious question. The bel is always a comparison between two things. No matter what system of units of measure you are working with at the time, you must always state a value as a reference before you can compare another value to it by using bels. Volts, dynes, Webers — it doesn't matter, a bel, or ear-related statement of "twice as loud" is always a ratio, not an absolute number. Unless a zero, or "no difference" point is placed somewhere, no comparison is possible. There are many positive and definite statements of reference in use today. But before we go over them, we should divide the "bel" into smaller units. "Twice as loud" will be a little crude to be used all the time. How about one tenth of a bel? Okay, the decibel it is, and 0 means "no difference, same as the reference". It seldom means "nothing". Now, if you double the power, is that twice as loud? No, it is only 3 dB more sound. If you double an electrical voltage, is it twice as loud? No, it is only 6 dB more sound. The unit quantities must follow nonlinear

progressions to satisfy the ears' demand.

Remember, decibels follow the ears. All other quantities of measure must be increased in whatever units necessary to satisfy the human requirements, and may not be easy to visualize. Sound in air, our beginning reference, is the least sound the human ear (young men) can detect at 1000 to 4000 Hertz. Bell Labs measured this value to be .0002 microbar, so we say 0 dB = .0002 microbar and work our way up from the bottom, or from the point at which there is "no perceivable sound to humans". Here is a chart of sounds and their ratings in dB, using .0002 microbar pressure change in air as our reference for "0 dB spl" (Sound Pressure Level).

## SOUND AND MUSIC REFERENCE

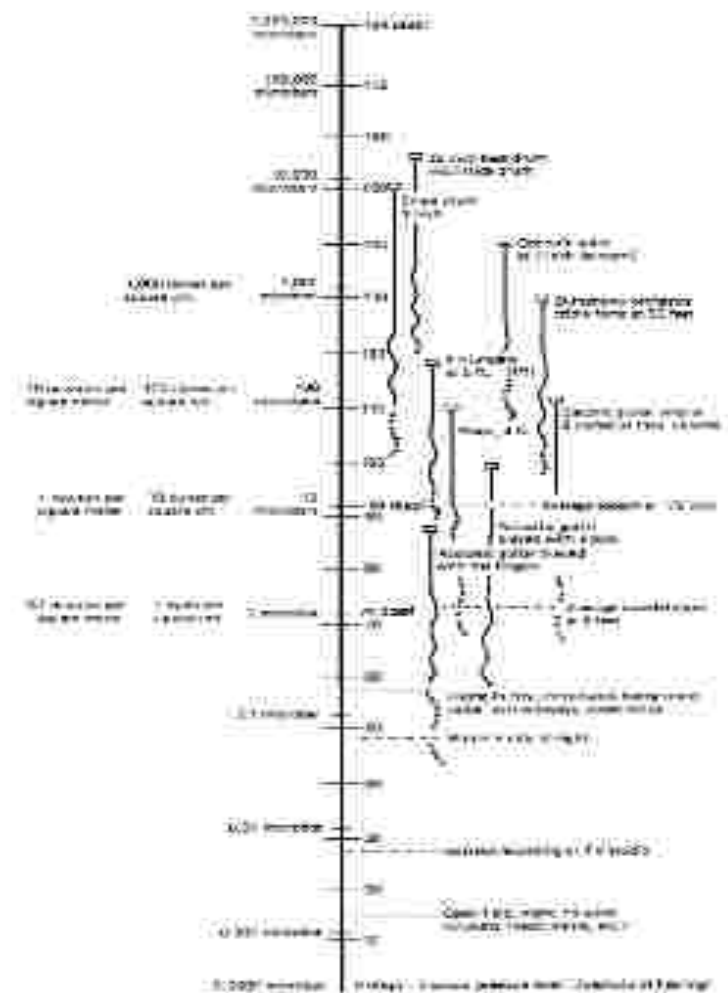

Since the reference is assumed to be the lowest possible audible value, dB spl (Sound Pressure Level) is almost always positive, and correctly written should have a + sign in front of the number. But it is frequently omitted. Negative dB spl would indicate so low an energy value as to be of interest to a scientist trying to record one cricket at 1,000 yds. distance, and is of no significance to the multichannel recordist. Far more to the point is the question "What is a microbar?" It is a unit of measurement related to atmospheric pressure and although it is extremely small, it must be divided down quite a lot before it will indicate the minimum pressure change in air that we consider minimum audible sound. This will give you a better idea of the sensitivity of the human ear.

One whole atmosphere, 14.70 pounds per square inch, equals 1.01325 bars. So one whole atmosphere in microbars comes out to be 1,013,250. One microbar of pressure change is slightly less than one millionth of an atmosphere, and you can find it on our chart as 74 dB spl. It is not terribly loud, but it is certainly not hard to hear. As a matter of fact, it represents the average power of conversational speech at 6 feet. This level is also used by the phone company to define normal earpiece volume on a standard telephone. Now think about that minimum audible threshold again:

.0002 microbar.

That's two ten-thousandths of a millionth part of one atmosphere!

This breakdown of one reference is not given just to amaze you, or even to provide a feel for the quantity of power that moderate levels of sound represent. Rather, it is intended to explain the reason we are saddled with a ratio/logarithm measurement system for audio. Adding and subtracting multi-digit numbers might be easy in this age of pocket calculators, but in the 1920's when the phone company began its research into sound and the human ear, a more easily-handled system of numbers became an absolute necessity. Convenience for the scientist and practical engineer, however, has left us with a system that requires a great deal of complex explanation before you can read and correctly interpret a "spec sheet" for almost any piece of gear.

Here are the formulas for unit increment; but they are necessary only for designers, and unless

you build your own gear, you won't have to deal with them. For power (watts) increase or loss, calculate by the following equation:

$$10 \text{ LOG}_{10} \frac{P2}{P1} = N \text{ (dB)}$$

For voltage, current or pressure calculations:

$$20 \text{ LOG}_{10} \frac{V2}{V1} = N \text{ (dB)}$$

Plotting the points resultant from using these equations we come up with the following chart. Once we have this chart, we can see the difference between the way humans perceive sound and the amount of force it takes to change air pressure. Unfortunately, the result is not a simple "twice as much pressure" of sound to be heard as "twice as loud". If you plot decibels as the even divisions on a graph, the unit increase you need is a very funny curve.

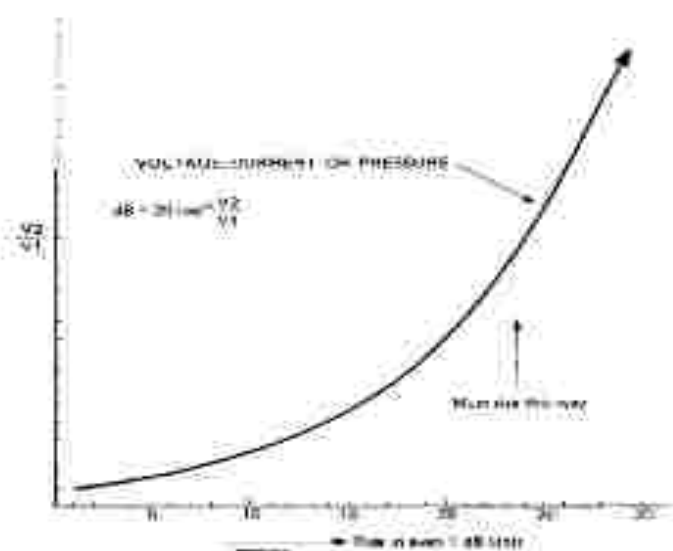

This is how the ear works, and we must adapt our system to it. We have no choice if we expect our loudspeaker to produce a sound that resembles the original sound we begin with. The high sensitivity to sound of the human ear produces a strong "energy" illusion that has confused listeners since early times. How powerful are the loudest sounds of music in real power? Can sound be used as a source of energy to do useful work, such as operating a car? For

any normally "loud" sound the answer is, regrettably, no! perhaps not so regrettably, consider what would happen if one pound of pressure was applied not to your head, but directly to your inner ear. One pound of air pressure variation is 170 dB spl! This amount of "power" might do some useful work — but not much, it's still only one pound and to make use of it you will have to stand one mile away or you will go deaf immediately.

If we reduce our sound power to realistic musical values, we will not be injured, but we will have almost nothing (in real power terms) to run the mic with!

This low available energy is the reason that high gain amplifiers are required for microphones.

When we take a microphone and "pick up" the sound, we do have some leeway in deciding how much energy we must have in order to operate the electrical part of our system. If we can decide that we don't have to truly hear the signal while we are processing it from point to point and we can wait until the electronic devices have done all their routing and switching before we need audible sound, we can lower the power of the signal. What is a good value for a reference here? Well, we need to have enough energy so that the signal is not obscured by hiss, hum, buzz or other unpleasant things we don't want, but not so high that it costs a fortune in "juice" or electrical power. This was a big consideration for the telephone company.

They now have the world's biggest audio mixing system, and even when they started out, electricity was not free. They set their electrical power signal reference as low as was practical at the time, and it has lowered over the years as electronic equipment has gotten better. In 1939 the telephone company, radio broadcasting, and recording industry got together and standardized 1 milliwatt of power as 0 dBm, and this is still the standard of related industries. Thus, a 0 dBm signal into a 600 ohm-line impedance will present a voltage of 0.775 volts.

Once again, we owe you an explanation. Why does it say ZERO on the meter? What is an ohm? Why 600 of them and not some other value? What's a volt? Let's look at one thing at a time.

1. The logic of ZERO on the meter is another hangover from the telephone company practice. When you start a phone call in California, the significant information to a

telephone company technician in Boston is — did the signal level drop? If so, how much? When the meter says ZERO it indicates (to the phone company) that there has been no loss in the transmission, and all is well. The reference level is one milliwatt of power, but the gain or loss is in the information the meter was supposed to display, so the logic of ZERO made good sense, and that's what they put on the dial. We still use it even though it's not logical for anything else, and the idea of a reference level described as a "no loss" ZERO, no matter what actual power is being measured, is so firmly set in the minds of everyone in the audio world that it is probably never going to change.

2. One ohm is a unit of resistance to the passage of electrical energy. The exact reasons for the choice of 600 ohms as a standard are connected to the demands of the circuits used for long distance transmission and are not simple or easy to explain. Suffice it to say that the worst possible thing you can do to a piece of electronic equipment is to lower the resistance it is expected to work into (the load). The lower the number of ohms, the harder it is to design a stable circuit. When you think about "load", the truth is just the opposite of what you might expect! 0 ohms is a "short circuit", not resistance to the passage of signal. If this condition occurs before your signal gets from California to Boston, you won't be able to talk — the circuit didn't "get there", it "shorted out". Once again, telephone company logic has entered the language on a permanent basis. Unless the value for ohms is infinity (no contact, no possible energy flow) you will be better off the higher the value, and many working electronic devices have input numbers in the millions or billions of ohms.

3. A volt is a unit of electrical pressure, and by itself is not enough to describe the electrical power available. To give you an analogy that may help, you can think of water in a hose. The pressure is not the amount of water, and fast flow will depend upon the size of the hose (impedance or resistance) as well. Increase the size of the pipe (lower the resistance, or Z) and pressure (volts) will drop unless you make more water (current) available to keep up the demand. This analogy works fairly well for DC current and voltage, but alternating current asks you to imagine



the water running in and out of the nozzle at whatever frequency your "circuit" is working at, and is harder to use as a mental aid. Water has never been known to flow out of a pipe at 10,000 cycles per second.

This reference level for a starting point has been used by radio, television, and many other groups in audio because the telephone company was the largest buyer for audio equipment. Most of the companies that built the gear started out working for the phone company and new audio industries, as they came along, found it economical to use as many off-the-shelf components as they could, even though they were not routing signals from one end of the world to the other.

Must we use this telephone standard for recording? Its use in audio has been so widespread that many people have assumed that it was the only choice for quality audio. Not so.

A 600-ohm, 3-wire transformer-isolated circuit is a necessity for the telephone company, but the primary reason it is used has nothing to do with audio quality. It is noise, hum and buzz rejection in really long line operation (hundreds and hundreds of miles).

Quality audio does not demand 600-ohm, 3-wire circuitry. In fact, when shielding and isolation are not the major consideration, there are big advantages in using the 2-wire system that go well beyond cost reduction. It is, as a system, inherently capable of much better performance than 3-wire transformer-isolated circuits.

Since TASCAM's mixers are designed to route a signal from a mic to a recorder, we think that the 2-wire system is a wise choice. The internationally accepted standard (IEC) for electronics of this kind uses a voltage reference without specifying the exact load it is expected to drive. The reference is this:

0 dB = 1 Volt

This is now the preferred reference for all electronic work except for the telephone company and some parts of the radio and television business. Long distance electronic transmission still requires the 600-ohm standard.

If your test gear has a provision for inserting a 600-ohm load, be sure the load is not used when working on TASCAM equipment.

Now that we have given a reference for our "0 dB" point, we can print the funny curve again, with numbers on it, and you can read voltages to go along with the changes in dB.

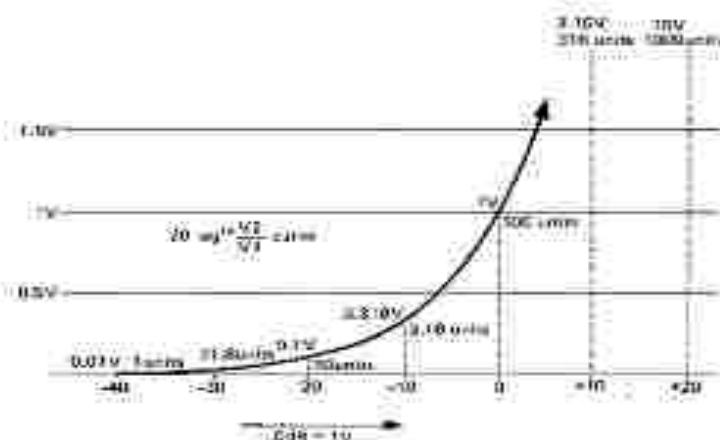

## IMPEDANCE MATCHING AND LINE LEVELS

All electronic parts, including cables and non-powered devices (mics, passive mixers and such), have impedance, measurable in ohms (symbol  $\Omega$  or  $Z$ ). Impedance is the total opposition a part presents to the flow of signal, and it's important to understand some things

about this value when you are making connections in your mixing system. The outputs of circuits have an impedance rating and so do inputs. What's good? What values are best? It depends on the direction of signal flow, and in theory, it looks like this:

OUTPUTS ————— Plug into ————— → INPUTS

It is generally said that the output impedance ( $Z$ ) should be as low as possible, 100 ohms, 10 ohms. The lower, the better, in theory. A circuit with a low output impedance will offer a low resistance to the passage of signal, and thus will be able to supply many multiple connections without a loss in performance or a voltage drop in any part of the total signal pathway. Low impedance values can be achieved economically by using transistors and integrated circuits, but other considerations are still a problem in practice.

1. The practical power supply is not infinitely large. At some point, even if the circuit is capable of supplying more energy you will run out of "juice".
2. Long before this happens, you may burn out other parts of the circuit. The output impedance may be close to the theoretically ideal "ohms" but many parts in the practical circuit are not. Passing energy through a resistance generates heat and too much current will literally burn parts right off the circuit board if steps are not taken to prevent catastrophic failure.
3. Even if the circuit does not destroy itself, too high a demand for current may seriously affect the quality of the audio. Distortion will rise, frequency response will suffer, and you will get poor results.

Inputs should have very high impedance numbers, as high as possible (100,000 ohms, 1 million ohms, more, if it can be arranged). A high resistance to the flow of signal at first sounds bad, but you are not going to build the gear. If the designer tells you his input will work properly and has no need for a large amount of signal, you can assume that he means what he says. For you, a high input impedance is a virtue. It means that the circuit will do its job with a minimum of electrical energy at the beginning. The most "economical" electronic devices in use today have input impedances of many millions of ohms. Test gear, for example, voltmeters of good quality must not draw signal away from what they are measuring, or they will disturb the proper operation of the circuit. A design engineer needs to see what is going on in his design without destroying it, so he must have an "efficient" device to measure with.

SOURCE (output) ————— Plug into ————— → LOAD (input)

The classic procedure for measuring output impedance is to reduce the load's impedance until the output voltage drops 6 dB (half the original power) and note what the load value is. In theory, you now have a load impedance that is equal to the output impedance. If you gradually reduce the load (increase the input impedance), the dB reading will return slowly to its original value. How much drop is acceptable? What load will be left when an acceptable drop is read on the meter?

Traditionally, when the load value (input  $Z$ ) is approximately seven times the output impedance, the needle is still a little more than 1 dB lower than the original reading.

Most technicians say, "1 dB, not bad, that's acceptable." We at TASCAM must say that we do not agree. We think that a seven-to-one ratio of input (7) to output (1) is not a high enough ratio, and here's why:

1. The measurement is usually made at a mid-range frequency and does not show true loss at the frequency extremes: What about the drop at 20 Hz or 30 kHz?
2. All outputs are not measured at the same time. Most people don't have twenty meters, we do. Remember, everybody plays together when you record and the circuit demands, in practice, are simultaneous. All draw power at the same time.

Because of the widely misunderstood rule of thumb — the seven-to-one ratio — we will give you the value for output impedance.

#### True Output Impedance

Even though the true output impedance may be low, say 100 ohms, it takes a lab to check the rule of thumb, so for the practical reasons we have explained, the use of the ratio method of impedance calculation must be changed to a higher ratio. We prefer 100:1 if possible and we consider 50:1 to be the minimum ratio that we think safe. Because of this, we will give you a number for ohms that you can match, Minimum Load Impedance. No calculations, we have made them already.

#### Minimum Load Impedance

**MAKE CERTAIN THAT YOU CONNECT NO TOTAL LOAD IMPEDANCE LOWER (numerically) THAN THIS FIGURE.**

LINE OUTPUT: 10k ohms

#### Nominal Load Impedance

Our specifications usually show 10,000 ohms as a Nominal Load Impedance. This load will assure optimum performance. Remember, any impedance lower than 10,000 ohms is more load.

#### Input Impedance

Input impedance is more straight forward and requires only one number. Here are the values for the 32.

LINE INPUT: 50k ohms

MIC INPUT: 10k ohms

If one output is to be "Y" connected to two inputs the total impedance of the two inputs must not be lower than the minimum load impedance, mentioned above, and if it becomes necessary to increase the number of inputs with slight reduc-

tion of the load specifications, you must check for a drop in level, a loss of headroom, low frequency response, or else suffer from a bad recording. If one input is 10,000 ohms, another of the same 10,000 ohms will give you a total input impedance (load) of 5,000 ohms. To avoid calculations you can do the following when you have two inputs to connect to one output.

Take the lower value of the two input impedance and divide it in half. If the number you have is greater than the minimum load impedance, you can connect both at the same time. Remember, we are not using the true output impedance we are using the adjusted number, the minimum output load impedance.

If you must have exact values here is the formula for dissimilar 2 loads or inputs:

$$R_x = \frac{R_1 \times R_2}{R_1 + R_2}$$

When you have more than two loads (inputs), just dividing the lowest impedance by the number of inputs will not be accurate unless they are all the same size. But if you still get a number that is higher than the minimum load impedance by this method, you can connect without worry.

If you must have exact values, here is the formula for more than 2 loads or inputs:

$$R_x = \frac{1}{\frac{1}{R_1} + \frac{1}{R_2} + \frac{1}{R_3} + \dots + \frac{1}{R_n}}$$

R<sub>x</sub> = Value of Total Load

#### Finding Impedance Values on Other Brands of Equipment

When you are reading an output impedance specification, you will occasionally see this kind of statement

Minimum load impedance = x ohms

or

Maximum load impedance = x ohms

These two statements are trying to say the same thing, and can be very confusing. The minimum load impedance says: please don't make the NUMBER of ohms you connect to this output any lower than x ohms. That's the lowest NUMBER. The second statement changes the logic, but says the exact same thing.

## REFERENCE LEVELS

Maximum load impedance refers to the idea of the LOAD instead of the number, and says: please don't make the LOAD any heavier. How do you increase the load? Make the number lower for ohms. Maximum load means minimum ohms, so read carefully.

When the minimum/maximum statement is made, you can safely assume that the manufacturer has already done his calculations, and the number given in ohms does not have to be multiplied. You can MATCH the value of your input to this number of ohms successfully; but as always, higher ohms will be okay (less load).

Occasionally, a manufacturer will want to show you that 7 times the output Z is not quite the right idea and will give the output impedance and the correct load this way, they will call the output impedance the True Output Impedance and then will give the recommended minimum LOAD impedance. It may be a higher or lower ratio than 7 times and will be whatever the specific circuit in question requires.

We should talk about one more reference, a practical one.

Anyone who has ever watched a VU meter bounce around while recording knows that "real sound" is not a fixed value of energy. It varies with time and can range from "no reading" to "good grief" in less time than it takes to blink. In order to give you the numbers for gain, headroom and noise in our mixers, we must use a steady signal that will not jump around. We use a tone of 1000 Hz and start it out at a level of -60 dB at the mic input, our beginning reference level. All levels after the mic input will be higher than this, showing that they have been amplified, and eventually we will come to the last output of the mixer — the line-out and the reference signal there will be -10 dB, our "line level" reference.

From this you can see that if your sound is louder than 94 dB spl — your mic will produce more electricity from a sound of 94 dB spl than -60 dB, all these numbers will be changed. We have set this reference for mic level fairly low. If you examine the sound power or sound pressure level (spl) chart on page 21 you will see that most musical instruments are louder on the average than 94 dB spl, and most commercial mics will produce more electricity than the -60 dB for a sound pressure of 94 dB, so you should have no problems getting up to "0 VU" or your recorder.

We should also make a point of mentioning that the maximum number on the chart on page 21 represents "peak power" and not average power. The reason? Consider if even some momentary part of your recording is distorted, it will force a re-recording and it is wisest to be prepared for the highest values and pressure even if they only happen "once in a while". On this point, statistics are not going to be useful, the average sound pressure is not the whole story. The words themselves can be used as an example. Say the word "statistics" close to the mic while watching the meters and the peak LED level detector. Then say the word "average". What you are likely to see are two good examples of the problems encountered in the "real world" of recording. The strong peaks in the "s" and "t" sounds will probably cause the LED's to flash long before the VU meter reads anywhere near "zero" while the vowel sounds that make up the word "average" will cause no such drastic action.

To allow peaks to pass undistorted through a chain of audio parts, the individual gain stages must all have a large reserve capability. If the average is X, then  $X + 20$  dB is usually safe for speech, but extremely percussive sounds may require as much as 40 dB of "reserve" to insure good results. Woodblocks, castanets, latin percussion (guiro, afuche) are good examples of this short term violence that will show a large difference between "LED flash" and actual meter movement. When you are dealing with this kind of sound, believe the LED, it is telling you the truth.

If you are going to record very loud sounds you may produce more electrical power from the mic than the mixer can handle as an input. How can you estimate this in advance? Well, the spl chart and the mic sensitivity are tied together on a one-to-one basis. If 94 dB spl in gives -60 dB (1 mV) out, 104 dB spl will give you -50 dB out, and so forth. Use the number, on our chart for sound power together with your mic sensitivity ratings to find out how much level, then check that against the maximum input levels for the various jacks on your mixer. If your mic is in fact producing -10 dB or line level, there is nothing wrong with plugging it into the line-level connections on the mixer. You will need an adaptor, but after that it will work!

Most mic manufacturers give the output of their mics as a minus-so-many-dB number, but they don't give the loudness of the test sound in dB, it's stated as a pressure reference (usually 10 microbars of pressure). This reference can be found on our sound chart. It is 94 dB spl, 10 microbars, 10 dynes per  $\text{cm}^2$  or 1 Newton per square meter. For mics, the reference "0" is 1 volt (dB). So, if the sound is 94 dB spl the electrical output of the mic is given as -60 dB, meaning so many dB less than the reference 0 = 1 volt. In practice you will see levels of -60 dB for low level dynamics, up to about -40 dB or slightly higher for the better grade of condenser mics available today. TASCAM recorders and mixers work at a level of -10 dB referenced to 1 volt (.316 volt) so, for 94 dB spl, a mic with a reference output of -60 dB will need 50 dB of amplification from your mixer or recorder in order to see "0 VU" (-10 dB) on your meter. Now, if the sound you want to record is louder than 94 dB spl, the output from the mic will be more powerful and you will need less amplification from your mixer to make the needles on your recorder read "0 VU".

## CALIBRATION

### NOTE:

Peak meters may vary considerably in the values which are equivalent to 0 VU. If any of the equivalent in your system uses peak meters, make sure you match your peak meter levels to correspond to 0 VU; do not automatically assume a direct correlation between the readings on the two different types of meters.

"Calibration" simply means matching all the reference levels in your recording system to ensure that signals from one element in the system are equally interpreted by all the other elements in the system.

If you're really serious about making true professional-quality recordings, then a reliable tone generator is a necessity in order to accurately calibrate your system. We recommend the TEAC TO-122A test-tone oscillator. When using a tone generator, select a signal that will be equivalent to 0 VU when passed through the device to which you are calibrating the 32. For example, if you are using a mixer with 0 dB referenced to 1 V (TASCAM mixers and recorders all use this reference level) and the mic input level is -60 dB and the line level (both input and output) is -10 dB, then, with the mixer's faders set to the shaded area, a 1 mV signal fed through the mic input or a 316 mV signal fed through the line input can be used to precisely establish the 0 VU level on the mixer. In this case (as with TASCAM line), -10 dB corresponds to 0 VU. If the equipment you are using references 0 dB to .775 V rather than 1 V, then a correction factor of 2.2 dB will have to be used to compensate for the difference.

The frequency of the tone used as the calibration signal has little effect on calibration, so any reasonable frequency may be used (400 Hz or 1 kHz is recommended). If you wish to calibrate your system without a tone generator, any source that produces a sustained tone, such as a musical instrument or even a vacuum cleaner, can be used to generate a reference signal; however, since there is no way to measure the reference level of such signal, experimentation with microphone placement and/or different volumes will be required to establish a reasonable recording reference level.

To calibrate, use a sustained tone and set the controls on your mixer and/or multitrack recorder so that their VU meters read 0 VU, and, passing the signal through the multitrack

recorder and/or mixer, set the controls on the 32 so that its VU meters also read 0 VU. After calibrating your system, make all subsequent level adjustments from the mixer or the first unit receiving input in the recording chain; do not change the controls on the rest of your equipment.

When using an oscillator for system calibration, start with a frequency setting somewhere midpoint in the audio range. This ensure that frequency limitations of metering circuitry will not affect accuracy. The audio range is three decades wide so choose a frequency typically in the 200 to 2,000 Hz area of the audio range.

All TASCAM mixers and recorders use the IEC standard, 1 V = 0 dB or 0 dBV, as the reference to which all measurements are made. The input level (and output level) that TASCAM gear uses as its 0 VU reference, is -10 dBV, or 0.316 V. If any of the gears you use have a different reference (eg. 0 = .775 V/600 ohms) then use the appropriate correction factor as follows:

Different correction factors:

0 dBV = 1 V	Voltage	0 dBm = 0.775 V/ 600 Ω 0 dBu = 0.775 V/ higher than 600 Ω
+6 dB	2 V	+8.2 dB
+1.78 dB	1.228 V	+4 dB
0 dB	1 V	+2.2 dB
-2.2 dB	0.775 V	0 dB
-6 dB	0.5 V	-3.8 dB
-8.2 dB	0.388 V	-6 dB
-10 dB	0.316 V	-7.8 dB
-12 dB	0.250 V	-9.8 dB
-12.2 dB	0.245 V	-10 dB
-20 dB	0.1 V	-17.8 dB

Note:

1. The "u" in "0 dBu" stands for "unbalanced".
2. Peak meters read 3 dB or so higher than RMS or VU meters, so when calibrating your system make sure that any peak meters are reading properly to compensate the difference.

## MORE INFORMATION IS AVAILABLE

We've tried to give you representative examples of some of the things you can do to get started, and you'll discover many more — some by way of happy coincidence, others after long hours of

concentration. If you're just getting into recording and want to expand your knowledge, more information is available.

## BIBLIOGRAPHY

Beranek, Leo L.  
ACOUSTICS  
McGraw-Hill Book Co. Inc.  
New York, New York  
1954

More concerned with exact formulae, but still very readable. It is not necessary to do calculations to gain knowledge from this textbook.

Beranek, Leo L.  
MUSIC, ACOUSTICS AND ARCHITECTURE  
John Wiley & Sons, Inc.  
New York, N.Y.  
1962

A technical survey on concert halls with much documentation. Worth reading, this author has many useful ideas to tell about the interface of science and art.

Clifford, Martin  
MICROPHONES: HOW THEY WORK AND HOW TO USE THEM

Tab Books  
Blue Ridge Summit, Pa.  
1977

An excellent low cost book for the beginner on microphone types, history and construction. The explanations given assume no prior knowledge and are very complete. Recommended.

Everest F. Allen  
ACOUSTIC TECHNIQUES FOR HOME AND STUDIO (3rd Printing)

Tab Books  
Blue Ridge Summit, Pa.  
1978

Low cost basic book. This book on studio acoustics is the easiest to read and understand of all the textbooks on the subject, and comes closest to dealing with the actual problems encountered in the home studio.

Everest F. Allen  
HANDBOOK OF MULTICHANNEL RECORDING

Tab Books  
Blue Ridge Summit, Pa.  
1976

A survey volume containing good information on all topics. Very clearly written and recommended for a beginner.

Nisbett, Alec  
THE TECHNIQUES OF THE SOUND STUDIO FOR RADIO, TELEVISION AND FILM

Hastings House Publishers, Inc.  
New York, N.Y.  
1976

Although not specifically written for the tape recorder, this 500 page book is well worth its cost. Very useful practical advice if you are working with speech (drama, commercial announcing, etc.)

Nisbett, Alec  
THE USE OF MICROPHONES

Hastings House  
New York, N.Y.  
1976

The author's point of view is basically radio, but has ability to communicate difficult concepts in very good, well illustrated,

Olsen, Harry F.  
ACOUSTICAL ENGINEERING  
D. Van Nostrand Company  
New York, N.Y.  
1957

and

Olsen, Harry F.  
MUSICAL ENGINEERING  
D. Van Nostrand Company  
New York, N.Y.  
1952

Anything you can find by this writer is worthwhile, and the latter book in particular will give scientific answers to questions. What frequency is the note D<sup>4</sup> above middle C? and can be used to translate one "language" into another. Extremely valuable.

Restinger, Michael  
ACOUSTIC DESIGN AND NOISE CONTROL, VOL. 1  
Chemical Publishing Company  
New York, N.Y.

1977  
Although this book is highly technical, the writing is very lucid and many examples are given to go along with the math. This writer is not afraid to draw conclusions and give his reasons for doing so in simple language.

Ramstein, Robert E.  
MODERN RECORDING TECHNIQUES

Howard W. Sams and Co.  
Indianapolis, Indiana  
1974

The first low cost book on studio practice. The equipment dealt with is somewhat outdated, but the theory is still the same. Excellent basic survey.

Tremaine, Howard M.  
THE AUDIO CYCLOPEDIA

Howard W. Sams and Co.  
Indianapolis, Indiana  
1976

This 1,700 page reference work is sure to contain the answer to almost any technical question you can think of. The writing assumes much prior knowledge and this book should be used with others that are more basic in their writing style if you are new to the field of scientific audio.

### SOME MAGAZINES OF INTEREST

"db" — THE SOUND ENGINEERING MAGAZINE  
1120 Old Country Road  
Plainview, N.Y. 11803

"MODERN RECORDING"  
14 Vandewater Avenue  
Port Washington, N.Y. 11050

"REIP" — RECORDING ENGINEER/PRODUCER  
1850 Whitley Street, Suite 220  
Hollywood, Ca. 90028

## THEORY OF OPERATION—MAINTENANCE

If you are new to high quality sound recording equipment, you should become aware of the fact that high quality sound requires high quality maintenance.

Recording studios that rent time by the hour are very fussy about maintaining their equipment. Tape recorders and other electronic gear in the studio are checked out before every session. And, if necessary, adjusted to "spec" by an "in house" service technician. He is usually prepared to correct any problem from a minor shift in circuit performance to major breakdown in a motor. He has a full stock of spare parts and all the test equipment he needs.

Now that you are running your own "studio" you will have to make some decisions about maintaining it, and your 32. You will have to become your own "in house" service technician. Well, what about the test gear and the spare parts? A stock of spare parts and a super deluxe electronic test bench can easily cost many times the price of the recorder. Fortunately, the most frequently needed adjustments use the least expensive equipment, and the very costly devices are only needed for major parts replacements such as drive and rewind motors or head assemblies. Replacing parts cannot be considered "daily maintenance" by any means, so we suggest that you leave the major mechanical and electrical repair to the Dealer Service Center. That's what it's for.

Adjustments to the motors — back tension and brake torque are not required often and can safely be left to dealer service. The adjustments for wow and flutter require several thousands of dollars of test gear to perform. It's not practical to consider doing these adjustments yourself unless you have fifty machines to service. Then it might pay to buy the test gear.

In order to help you make plans about the more routine adjustments to your 32, we have made this section of the manual as easy to understand as technology will allow. It's a short course in tape recorder theory as well as a list of adjustments and will help you to understand what is going on inside when you record. Read the manual, decide what test equipment you can afford (although it is not violently expensive, it is not free) and determine what service you can do yourself.



## CLEANING

### IMPORTANT:

Do not overlook the importance of cleaning. Insufficient cleaning is the number one cause of the degradation of performance levels.

The first thing you will need for service is definitely the least expensive – Cleaning fluids and swabs. The whole outfit, 2 fluids and all the cotton swabs you'll need for months cost less than one roll of high quality tape. We can't stress the importance of cleaning too much. Clean up before every session. Clean up after every session. Clean up every time you take a break in the middle of a session (we're serious). How come? Well there are two good reasons we can think of right off the top:

1. Any dirt or oxide buildup on the heads will force the tape away from the gaps that record and playback. This will drastically affect the response. Even so small a layer of dirt as one thousandth of an inch will cause big trouble. All the money you have paid for high performance will be wiped out by a bit of oxide. Wipe it off with head cleaner and get back to normal.
2. Tape and tape oxide act very much the same as fine sandpaper. The combination will grind down the tape path in time. If you don't clean off this abrasive on a regular basis, the wear will be much more rapid and, what's worse, it will become irregular. Even wear on heads can be compensated for by electronic adjustments for a time, but uneven wear can produce notches on heads and guides that will cause the tape to "skew" and skip around from one path to another, making adjustment impossible. This ragged pathway chews up the tape, thus dropping more abrasive, thus causing more uneven wear and so – a vicious spiral that can't be stopped once it gets a good start. The only solution will then be to replace not only the heads, but all the tape guides as well. Being conscientious about cleaning the tape path on the 32 will more than double the service life of the head assembly.

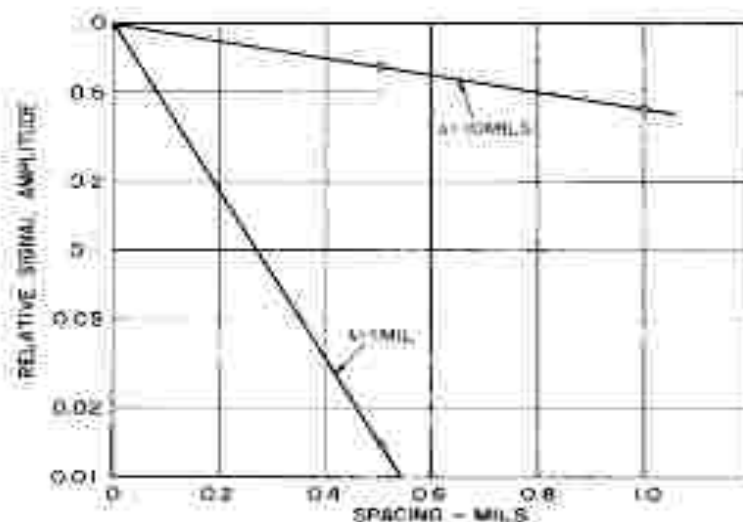

Fig. 2-7 Curves showing fall-off of reproduced signals versus spacing from reproducer head. (Courtesy, Minnesota Mining and Manufacturing Co.)

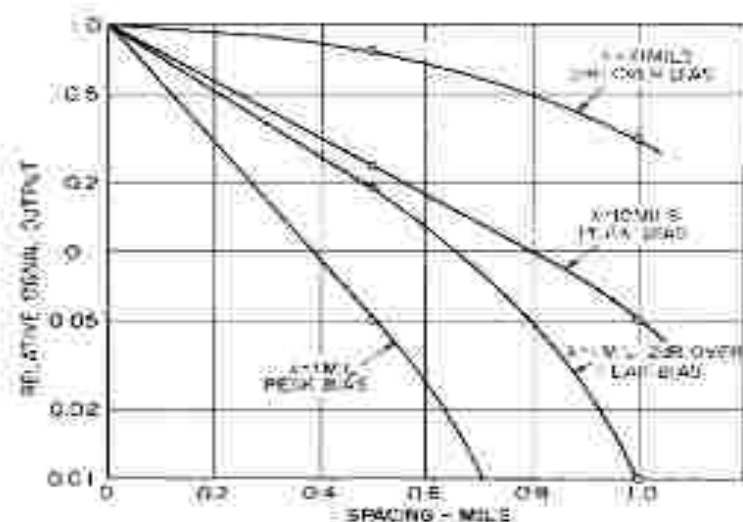

Fig. 2-8 Curves showing the fall off of recorded signals versus spacing from recording head. (Courtesy, Minnesota Mining and Manufacturing Co.)

## DEGAUSSING (DEMAGNETIZING)

### IMPORTANT:

1. Do not overlook the importance of degaussing. Magnetism in the tape can significantly degrade performance. In extreme causes, the heads may not respond to signals at all.
2. Turn off the deck before degaussing.
3. Do not turn the degausser (E-3) off or on while it is in close proximity to the tape path.
4. Keep all recorded tape a safe distance from the degausser.

A little stray magnetism goes a long way. A long way towards making trouble for your tapes. It only takes a small amount (0.2 gauss) to cause trouble on the record head and playing 10 rolls of tape will put about that much charge on the heads and other ferrous parts of the tape path. A little more than that (0.7 gauss) will start to erase high frequency signal on previously recorded tapes. Demagnetize the whole tape path, including the tips of the tension arms every six fully played 10-1/2" reels. This is a fair "rule of thumb" even though it may be a bit hard to keep track of. Fast motion isn't as significant to the heads, so we don't give an hourly reference. It's the record/play time that counts.

Degaussing is always done with the recorder turned off. If you try it with the electronics on, the 60 cycle current pulses produced by the degausser will look just like 60 Hz audio to the heads, at about 10,000 VU and will seriously damage the electronics and/or the meters. Turn off the machine, turn on the degausser at least 3 feet away from the recorder. Move slowly in to the tape path. Move the degausser slowly up and down in close proximity to all ferrous parts and, slowly move away to at least 3 feet before turning off.

It's a good idea to concentrate when you are degaussing. Don't try to hold a conversation or think of anything else but the job you are doing. If the degausser is turned off or on by accident while it is near the heads, you may put a permanent charge on them that no amount of careful degaussing will remove — head replacement time again, we're sorry to say. Make sure you are wide awake for this procedure.

A clean and properly demagnetized tape recorder will maintain its performance without any other attention for quite some time. Even if it does drift as a recorder, it won't ruin previously recorded material, and getting it back in good shape will not be too difficult.

## TEST EQUIPMENT/MATERIALS

To make electronic adjustments, you need test gear, so let's go over what's necessary.

### 1) Alignment Tapes

You need one for each speed that the recorder operates at. For the 32 the specs are:

Reference fluxivity:	250 nWb/m
Equalization standard:	NAB
15 ips (38 cm/sec)	3180 $\mu$ s + 50 $\mu$ s
7-1/2 ips (19 cm/sec)	3180 $\mu$ s + 50 $\mu$ s
Equalization standard:	IEC - 1
15 ips (38 cm/sec)	= +35 $\mu$ sec
7-1/2 ips (19 cm/sec)	$\infty$ +70 $\mu$ sec

These test tapes are made by several companies, but there are many different tape specs. Be sure you have the right one. See page 39.

Reference Fluxivity — How much magnetic energy is necessary on the tape to make the meter read "0 VU" in playback? This is the "benchmark", or standard you tune your playback electronics to. 250 nano Webers per meter is the correct value for the 32. If a lower or higher "Reference Fluxivity" is used to set up the playback, all your other measurements will be off.

NAB Equalization — Here we have a lot to talk about. The process of magnetic recording is far from "flat." Every circuit in a tape recorder will alter the level of signal with respect to its frequency — some deliberately, some unavoidably. The deliberate errors are used to overcome the unavoidable problems. Here is a selection of frequency response graphs at various points in the recording process:

1. The input signal starts this way in the beginning (FLAT).



Fig. 2-9

2. EQ to overcome head loss at high frequency and bass anomalies (NAB)  
Deliberate error



Fig. 2-10

3. Record Head Response  
(6 dB per octave rise until gap in head approaches wavelength)  
Unavoidable error  
Small wavelengths (high frequencies) are partially erased as fast as they are recorded.

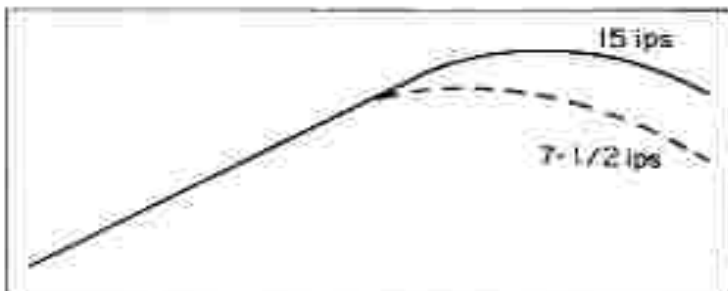

Fig. 2-11

We will assume something is recorded, but it's not flat on the tape either. Now we'll play it back.

4. Reproduce Head Response  
(6 dB per octave rise again, same as record head).  
Unavoidable error,  
Small wavelengths are not picked up by gap.

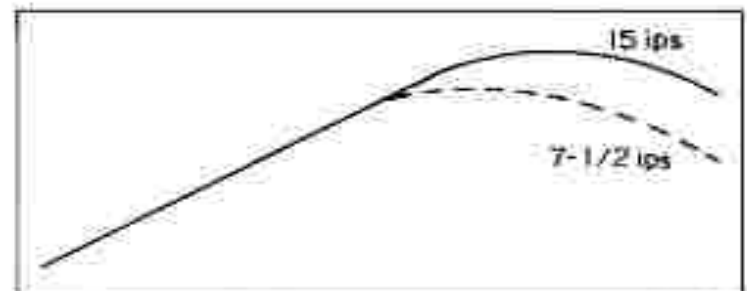

Fig. 2-12

5. Reproduce EQ

Now we must overcome the characteristic response of heads.

Big deliberate error

Helps lower tape hiss as well as restoring proper levels to high frequencies.

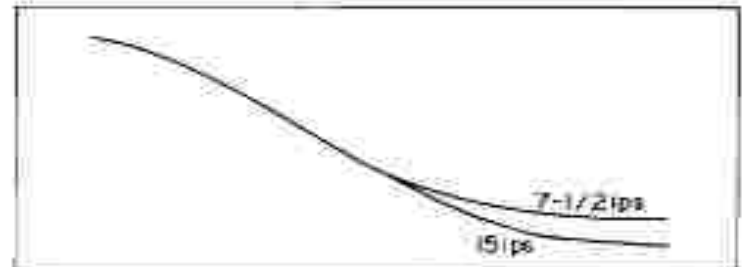

Fig. 2-13

6. The result of all this equalization is this (hopefully).



Fig. 2-14

The idea is to use the electronics that are adjustable to cope with the problems that are caused by the nature of the magnetic recording process. We can't change the basic laws of magnetic physics, so we change the record and reproduce equalization. Now comes the sticky part. How much EQ do we use in each stage? If every manufacturer of tape recorders used their own standard, their idea of what was best, there would be no compatibility. Tapes made on one recorder would not reproduce properly on another of different make. The standards for

record and reproduce equalization are established by societies of scientists, engineers and users in the profession. They are:

- NAB** National Association of Broadcasters
- IEC** International Electrotechnical Commission
- CCIR** International Radio Consultive Commission
- DIN** Deutsche Industrie Normen

Unfortunately, they don't all agree. Each organization has a slightly different approach to solving the problems of tape recording. Scientists and engineers are human, as well, and have been known to disagree, sometimes violently about what ways are best. Advances in the manufacture of tape, improvements in head design, and the lowering of electronic circuit costs have made bizarre solutions quickly change into practical realities. The optimums have shifted and will probably continue to do so. Standards are set by man, not cast in stone.

But while the scientists are boxing in the conference room, we would like to be recording, so depending on the equalization requirements of its final destination, TASCAM has selected the NAB and IEC standards for record/reproduce equalization as the recommendation for the 32. See page 39 for details.

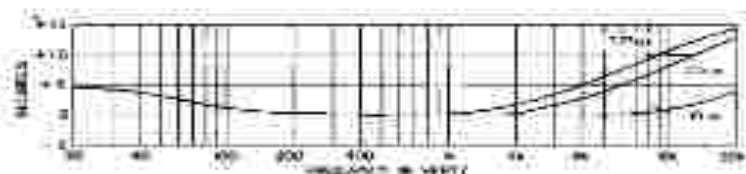

Fig. 2-15 Typical recording (pre-equalization) for 1/4-inch tape recorders using NAB characteristics.

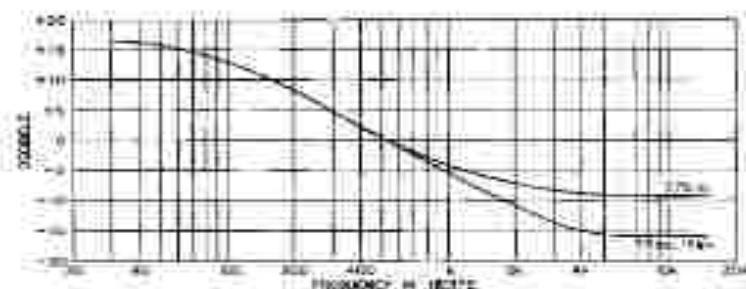

Fig. 2-16 Typical post-equalization for 1/4-inch tape recorders using NAB characteristics.



Fig. 2-17 Typical pre-equalization characteristics for 1/4-inch tape recorders running at 7.5 and 15 ips using the CCIR (DIN) standard.

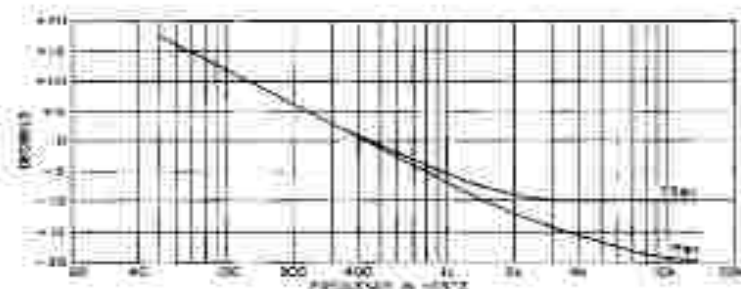

Fig. 2-18 Typical post-equalization curves for 1/4-inch recorders using CCIR characteristics, at 7.5 and 15 ips.

You will need a separate reference tape for each speed. The curves are not the same.

Since these Reference Standard tapes cost about 3 times the price of a big roll of the best blank tape, plan on storing them carefully in a place that will not encounter any magnetic fields that might damage them — away from loudspeakers, guitar pickup, tape recorder and record player motors, power amplifiers (magnetic field surges in big transformers when amps are turned on and off can be very powerful) or anything magnetic that might alter the quality of the reference standard. If you don't damage them physically or magnetically (don't play them on dirty or magnetized recorders, or loan them out to the careless) they will last for several years.

If it is not possible to obtain a tape that has both the NAB EQ and a fluxivity of 250 nWb/m, select the NAB EQ as the preferred single standard. A different reference fluxivity requires only that you make a level correction once. Just use a different mark on the meter instead of "zero." A different EQ curve requires a different amount of correction for each frequency and is much harder to use — especially for a beginner. Level corrections for different reference fluxivity:

		Use this instead of "0" VU
15 ips	185 nWb/m — (Ampex operating level)	-3 VU
	200 nWb/m — (STL, MRL)	-2 VU
7-1/2 ips	185 nWb/m operating sweep frequencies	-3 VU
	200 nWb/m operating sweep frequencies	-13 VU
	200 nWb/m operating sweep frequencies	-2 VU
	200 nWb/m operating sweep frequencies	-12 VU

Below are tabulated some commonly encountered flux levels along with their dB differences, and their differences in dB from 185 nWb/m.

Flux Level nWb/m	Flux Level Difference in dB	Difference from 185 nWb/m in dB
150	0.56	1.82
160	0.53	1.26
170	0.50	0.73
180	0.24	0.24
185	0.23	0.00
190	0.45	0.23
200	0.42	0.69
210	0.40	1.10
220	0.39	1.51
230	0.27	1.80
240	0.26	2.26
250	0.25	2.62
260	0.24	2.96
3-dB above Ampex operating level	0.04	3.00
261.32	0.28	3.28
270	0.32	3.00
280	0.30	3.00
290	0.29	4.20
300	0.28	4.40
310	0.28	4.40
DIN Standard	0.28	4.70
320	0.27	5.02
340	0.26	5.29
350	0.25	5.54
360	0.24	5.76
5-dB above Ampex operating level	0.22	6.00
369.12	0.62	6.07
370	0.23	6.29
380	0.23	6.48
390	0.22	6.48
400	0.22	6.70

**Note:**  
Add 0.7 dB for European Measurement Method using Magnetometer.

### IEC Correction Chart (illus.)

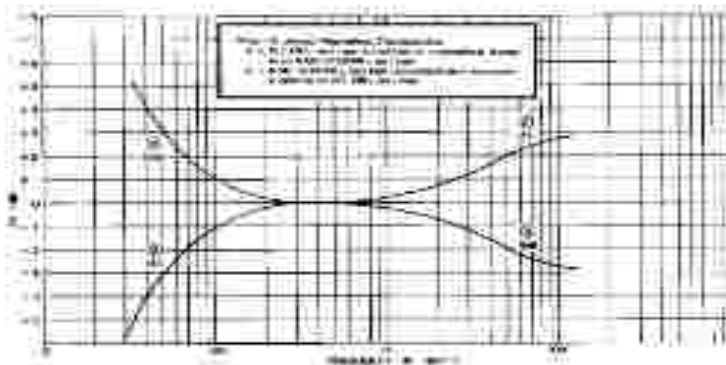

Fig. 2-19

If you must use IEC EQ tapes, these readings are correct. IEC has less boost in playback, the tape will read progressively higher as frequencies rise when played on a NAB adjusted recorder. At 250 nWb/m reference read these numbers to set IEC-1 EQ.

31.5 50 125 400 1K 3K 6.3K 8K 10K 16K 18K 20K  
-5.4 -3.0 -0.6 0 +0.2 +1.2 +2.3 +2.6 +2.7 +2.9 +3.0 +3.0 dB

See "Test Tapes for the 32" on page 39.

Since the low frequency EQ on the 32 is fixed, the differences are academic. On to the next piece of test equipment.

### 2) VTVM or FET Multimeter

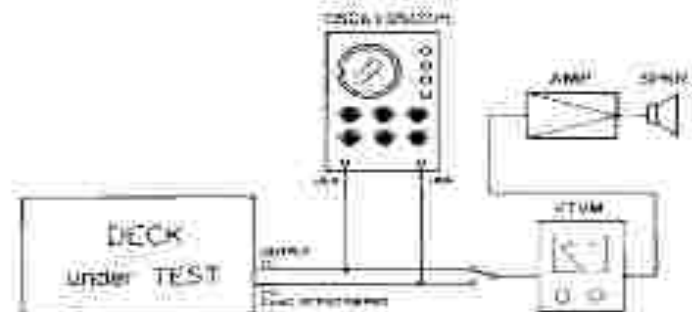

Fig. 2-20 Head Alignment Fine Adjustment Set-up and Test Connections (REPRODUCE)

Use a VTVM or FET multimeter with an input impedance of at least 1 megohm that can read levels down to  $-70$  (full scale) you can think of this as a very accurate VU meter of very wide range. Meters with lower input impedances will draw power from the circuits to be measured and will affect the readings. Meters that have adequate input impedance but do not read below  $-40$  (0.01 V) can be used for reference levels and frequency response measurements, but will not be capable of making signal-to-noise, erase efficiency or bias circuit measurements where the output of the circuit being adjusted is expected to be very low. Meter MUST have wide, flat frequency response (minimum = 10 Hz - 1 MHz).

This tool is not cheap and is just as important as the test tapes. Without a good reference meter, you can do very little in the way of accurate adjustment. Spend as much as you can here. It's worth it. Next...

### 3) Signal Generator or Oscillator

Here you get a break. A simple oscillator will do all the work and won't send you to the poor house. There are several on the market for

around \$100. The local electronic surplus store can be a good source for test equipment that can be re-calibrated by the manufacturer for a reasonable cost. If you get one with a meter on it, you won't have to calibrate its output with the big meter as often. This device is very useful in a studio for troubleshooting — a good investment. It should have at least the following frequencies.

40 Hz — 100 Hz — 400 Hz — 1 kHz — 4 kHz — 10 kHz — 15 kHz — 18 kHz

Sine wave is all that is required, at a distortion of no more than 5%. Most modern units do better than this easily. This unit is the work-horse on the equipment list. Whether you are reading the big meter (FET) or the meters on the recorder, you will need a signal to read, this instrument or the test tapes will provide you with signals.

Test tapes, tone generator, VTVM or FET meter. . . This is the basic package and will do almost every adjustment in the sequence — except the first one . . .

#### 4) The Oscilloscope

Even a simple one is not cheap. Fortunately, a simple one is all you need. You can spend \$6,000 and more for the big ones, but for this purpose \$100 — \$200 will be more than enough. It must have a "vertical" and a "horizontal" amplifier and an X-Y mode. That's all you use to do the one adjustment you need it for. Assuming that the motors are not in need of attention (that's for Dealer Service), Azimuth, or head alignment is the number one step in maintenance . . . so let's begin.

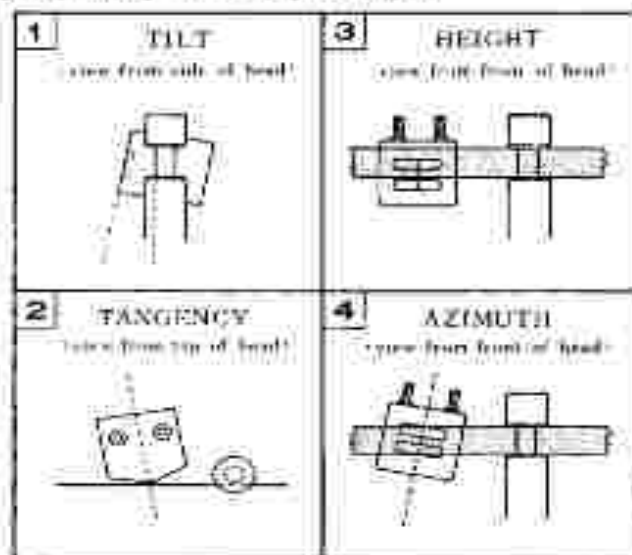

Fig. 2-21 Head Mis-Alignment Example

The gaps in the heads that do the erasing, recording, and reproducing must be precisely perpendicular to the tape. PRECISELY. Even a tiny error in alignment will make problems for the recorder. If the heads are not in alignment, both with the tape, and with respect to each other, tones recorded on one head will not play properly on the other. In the table below, the error is shown with the loss in dB. The amount of tilt is given in the fractions of a single degree called minutes, 60 minutes to a degree. As you can see, it only takes 1/4 degree to cause big trouble.

1-Mil Wavelength		5-Mil Wavelength		15-Mil Wavelength	
Loss in dB	Azimuth Error in Minutes	Loss in dB	Azimuth Error in Minutes	Loss in dB	Azimuth Error in Minutes
0.5 dB	14.86	0.5 dB	7.43	0.5 dB	3.71
1.0 dB	20.90	1.0 dB	10.45	1.0 dB	5.22
2.0 dB	29.21	2.0 dB	14.60	2.0 dB	7.30
3.0 dB		3.0 dB	17.67	3.0 dB	8.83
4.0 dB		4.0 dB	20.16	4.0 dB	10.08
5.0 dB		5.0 dB	22.16	5.0 dB	11.13
6.0 dB		6.0 dB	24.08	6.0 dB	12.04
7.0 dB		7.0 dB	25.68	7.0 dB	12.84
8.0 dB		8.0 dB	27.09	8.0 dB	13.54
9.0 dB		9.0 dB	28.38	9.0 dB	14.18
10.0 dB		10.0 dB	29.50	10.0 dB	14.75

Fig. 2-22 Loss due to azimuth misalignment for 43-mil quartertrack. (Courtesy, Ampex Corp. Test Tape Laboratory)

Since the 32 can use a single head (head #2 in the stack) to perform all functions (recording, sync reproduce and reproduce) it won't hurt the recorder to use the "whizbang studio alignment" procedure, which is to do nothing about alignment at all. You won't notice anything wrong with the sound you make, but there are drawbacks:

1. Your tapes won't play properly on any other recorder (whizbang standards are unique).
2. No accurate tune-up of the recorder will be possible, as most test procedures use one head as a reference for the other. To do this, they must be aligned perfectly.

Thread the 7-1/2 ips test tape on the recorder and find the operating level section of the tape. Connect the outputs for tracks 1 and 2 of the recorder to the 2 inputs of an oscilloscope, track 1 to the vertical input that makes the beam draw lines up and down and 2 to the horizontal input (draws lines left to right). Set the scope to the "Vector" or XY mode. You will have to consult the instruction book

for the scope to determine how to do this. We don't know what brand of test gear you have. Play the tone, and this is what you should see:

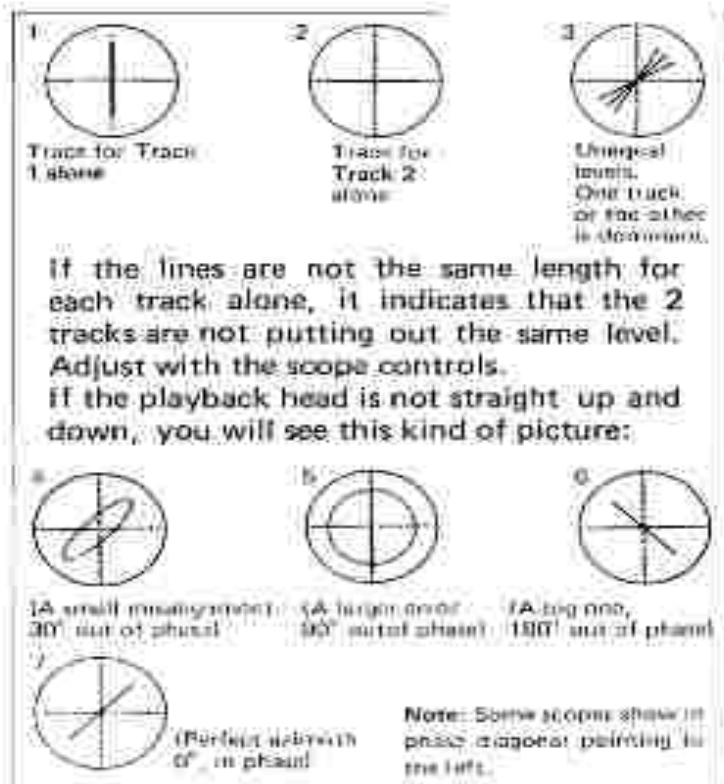

Fig. 2-23 Phase Shift

How much distance error is involved depends on the frequency or pitch of the tone and the speed of the tape. One "cycle" per second at 15 ips would be hard to misalign. To get scope picture No. 6, you would have to separate the gaps in the playback head by 7-1/2 inches, but one cycle per second is not audio. How about 1,000 cycles per second of tape travel? At 15 ips, the separation or tilt in the head for scope picture No. 6 becomes 0.0075 inch. And at 15,000 Hz at 15 ips it's 0.0005 inch. Not much tilt will produce a big error. Slower tape speeds mean even smaller spacings and good azimuth becomes even more important. The proper method of adjustment is to look first at a long wave, say 1000 cycles, and make a coarse adjustment. Then work up in frequency, adjusting shorter and shorter wavelengths smaller and smaller amounts. If you start adjusting with 10 kHz or 15 kHz, you can make a big mistake. Here's why. . . . Since the very short wavelengths are very close together on the tape, it is possible to get a good "picture" on the scope by adjusting one full cycle off. If you work up to 15K,

checking and adjusting as you go, you will avoid this mistake.

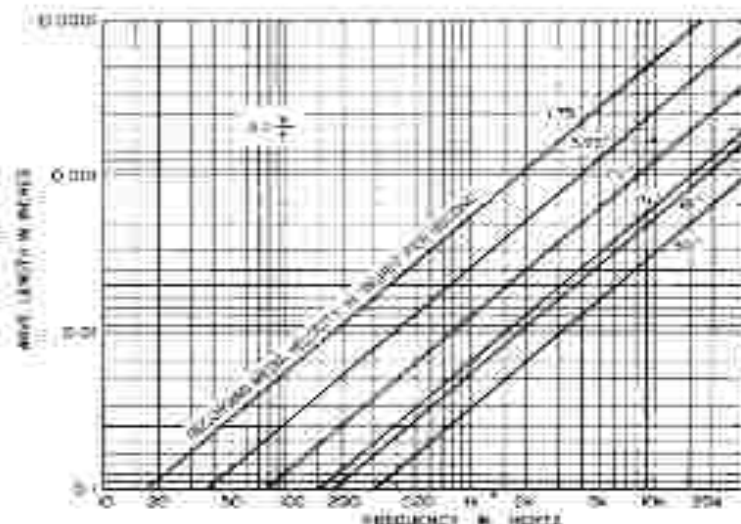

Fig. 2-24 Velocity of recording media versus recorded wavelength in inches for a given frequency.

Once you have everything set up — the reference tape is playing, the scope is running and showing the x-y display, you need a screwdriver and this diagram to find the right adjustment point. Adjusting the screw will rotate the head very slightly.

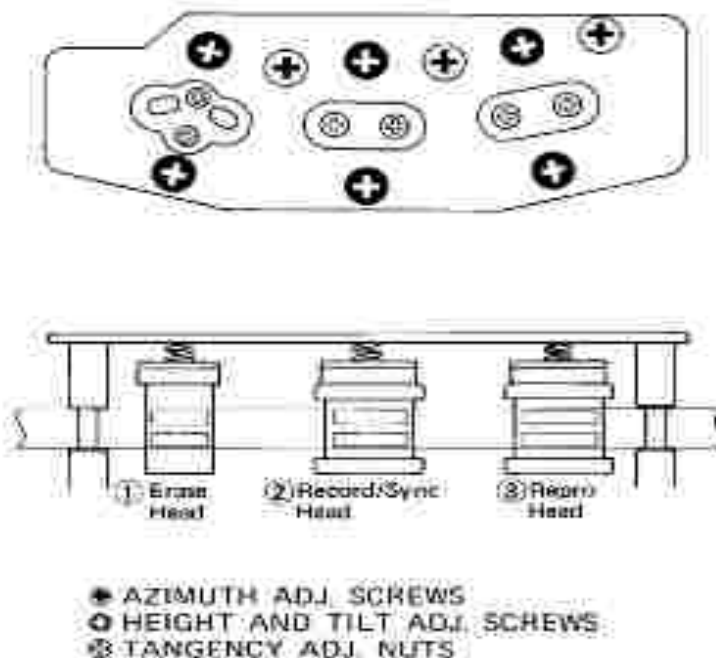

Fig. 2-25 Head Adjustment Screws and Alignment

### 5) Test Tapes for 32 (reproduce alignment)

#### NAB Equalization:

- STL 3 or MRL 21J205 = Tape speed 15 ips
- STL 22 or MRL 21T204 = Tape speed 7.5 ips
- Reference fluxivity; 250 nWb/m
- Time constant;  $3,180 \pm 50 \mu\text{sec}$ .

#### IEC-1 Equalization:

- STL 3-IEC or MRL 21J103 = Tape speed 15 ips
- Reference fluxivity; 200 nWb/m
- Time constant;  $\infty + 35 \mu\text{sec}$ .
- STL 22-IEC or MRL 21T102 = Tape speed 7.5 ips
- Reference fluxivity; 200 nWb/m
- Time constant;  $\infty + 70 \mu\text{sec}$ .

— or —

#### NAB Equalization:

- TEAC YTT-1044 = Tape speed 15 ips
- Reference fluxivity; 185 nWb/m
- Time constant;  $\infty + 35 \mu\text{sec}$

#### IEC-1 Equalization:

- TEAC YTT-10432 = Tape speed 7.5 ips
- Reference fluxivity; 185 nWb/m
- Time constant;  $\infty + 70 \mu\text{sec}$ .

All specs are identical with STL or MRL tapes except for the reference fluxivity which is 185 nWb/m, and thus, its reproduce output level will be 3 dB lower compared with 250 nWb/m fluxivity. Calibration level under "Reproduce Calibration" refers 0 VU as 250 nWb/m.

**CAUTION:** As mentioned before TASCAM has selected the NAB and IEC standards for record/reproduce EQ as the recommendation for the 32. The NAB standard is chosen for the models which are to be sold in the U.S.A. and Canada, or for General Export models, while the IEC standard chosen for the models designated for Europe, U.K. and Australia.

**Note:** If necessary, inter-switching between the NAB and IEC standards can be accomplished by simply removing and repatching the jumper wires on five points of the amplifier. The details are explained as a note in the inserted schematic of the amplifier section.

The next step is to play all the signals from the lowest frequency to the highest on the 7 1/2 ips alignment tape — one play for each head position (2-3), and DO NOTHING. Just have a look. It's not a good idea to turn knobs just to "see what happens." Just because an adjustment can be made doesn't mean it's necessary. The recorder is very solid and is well adjusted at the factory, so in all test and maintenance procedures, check first, then if something is not right, adjust. Taking your time will save endless grief. A new machine is very likely to be "on the money" when you get it and if you keep it clean and degaussed will drift away from top shape very slowly. It's not necessary to plan on a major overhaul when it comes out of the box.



## ELECTRICAL ADJUSTMENT PROCEDURE

### 1) Location of Electrical Adjustments:

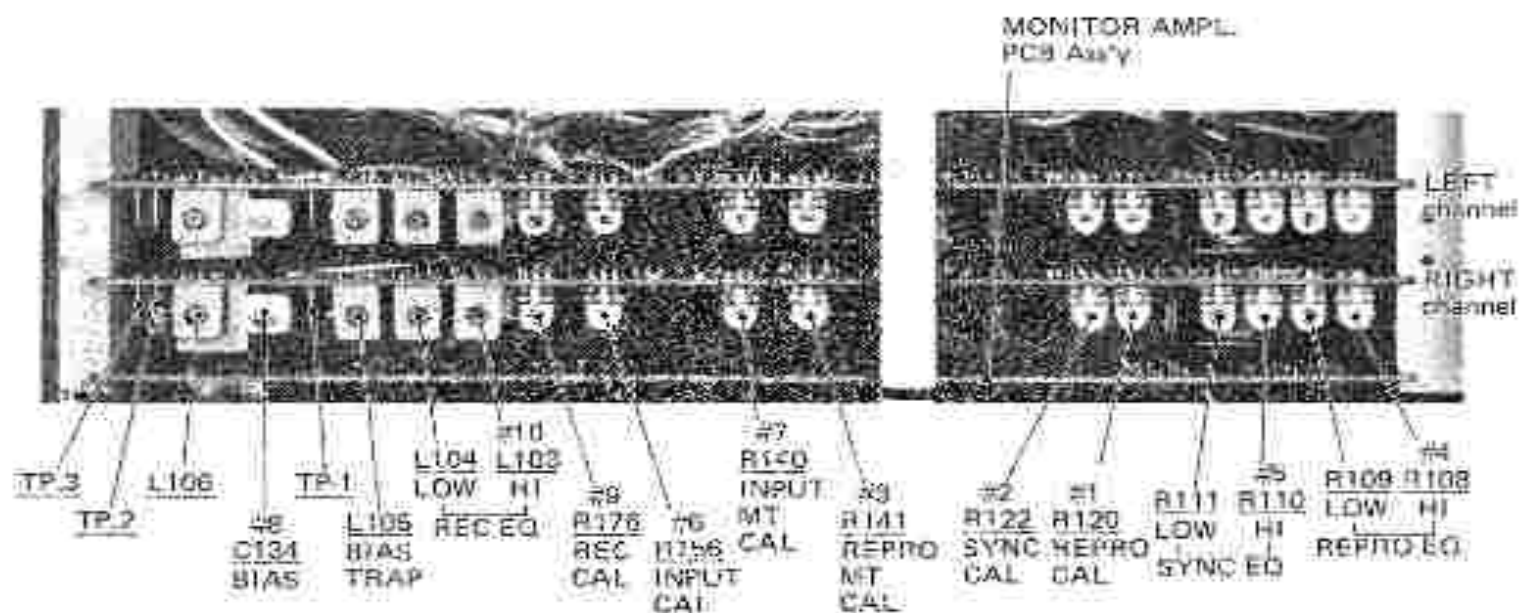

TRIM POT NUMBER	REFERENCE NUMBER		FUNCTION
	Tape Speed 15 ips	Tape Speed 7-1/2 ips	
#1	R120 2k ohms	—	REPRO CAL
2	R122 2k ohms	—	SYNC CAL
3	R141 50k	—	REPRO METER CAL
4	R108 10k	R109 10 kohms	REPRO EQ
5	R110 20kohms	R111 20 kohms	SYNC EQ
6	R156 2k	—	INPUT LEVEL
7	R140 50k	—	INPUT METER CAL
8	C134 100p Max.	—	BIAS LEVEL
9	R176 20k	—	REC LEVEL
10	L103 1.4 mH	L104 2.4 mH	REC EQ
—	L105	—	RECORD BIAS TRAP
—	L106	(BIAS TUNING)	CAUTION: Don't attempt any adjustments of L106 except for purposes described under the MAINTENANCE section.

## 2) Reproduce Calibration:

(DO NOT ATTEMPT TO CALIBRATE WITH DBX ENGAGED!)

When we're sure the reproduce and record head are properly aligned, we can move on to the electronic adjustments.

The first step here is to actually check your meter calibration. To open the bottom panel, remove the 8 binding screws. Rotate OUTPUT knob on the front panel to the position "7".

Connect the VTVM to the output terminal of left channel. Turn the machine ON, and thread the 15 ips alignment tape. Play the "operating level" portion (a voice on the tape identifies each section at the beginning).

Switch the OUTPUT SELECT on the 32 to REPRO. Adjust the playback or "reproduce" level with trim pot # 1 R120, 2k ohms (REPRO CAL), until the VTVM reads -10 dB (0.3 V).

Switch the OUTPUT SELECT to SYNC. Adjust the reproduce level with trim pot # 2 R122, 2k ohms (SYNC CAL), until the meter reads -10 dB (0.3 V). Now read the meter on the front panel of the 32. It should read "0 VU".

If it does not, adjusting trim pot # 3 R141 50k ohms (METER CAL) will allow you to set the meter on the 32. You adjust the 32 meter to read "0 VU", not -10, the reading on the VTVM. The meter will read 0 at any voltage you set it for, the correct one is 0.316 Volt. This is the right setting for the 32. You read -10 dB (0.3 V) on the VTVM and adjust the 32 meters to read 0 VU at this level.

Channel R still remains to be checked and adjusted, but as you can see, the adjustments are the same as for channel L. In brief:

1. Play the tape "operating level"
2. Read the VTVM for head 3, REPRO.
3. Adjust for -10 dB (0.3 V) reading with trim pot # 1.
4. Switch to SYNC on OUTPUT SELECT.
5. Read the VTVM. Adjust trim pot # 2.
6. Read the meter on the 32 - it must read 0 VU.
7. Adjust the meter trim pot # 3 R141, 50k ohms METER CAL.

One more word of encouragement. The circuits in the 32 are very stable. Most of the time you will make a reading and not have to adjust anything. When something does go wrong, you will be able to fix it very quickly, and get back to recording.

In summary, with the VTVM and test tape, you have adjusted the reproduce level on the 32 to the test tape. But your reproduce reference is not yet complete. You have only "zeroed" one point on a line of frequency response. To establish the rest of the line, you must measure and adjust one more frequency.

Advance the alignment tape for 15 ips to the section that is recorded at 16 kHz and adjust the trim pot marked REPRO EQ #4, R108, 10k ohms - switch to SYNC on the OUTPUT SELECT, and adjust trim pot #5, R110, 20k ohms SYNC EQ.

The reading for both positions should be 0 VU on the 32 meters. Since you have checked and adjusted the reproduce meter circuit, you now can use the meters on the 32 for the test readings.

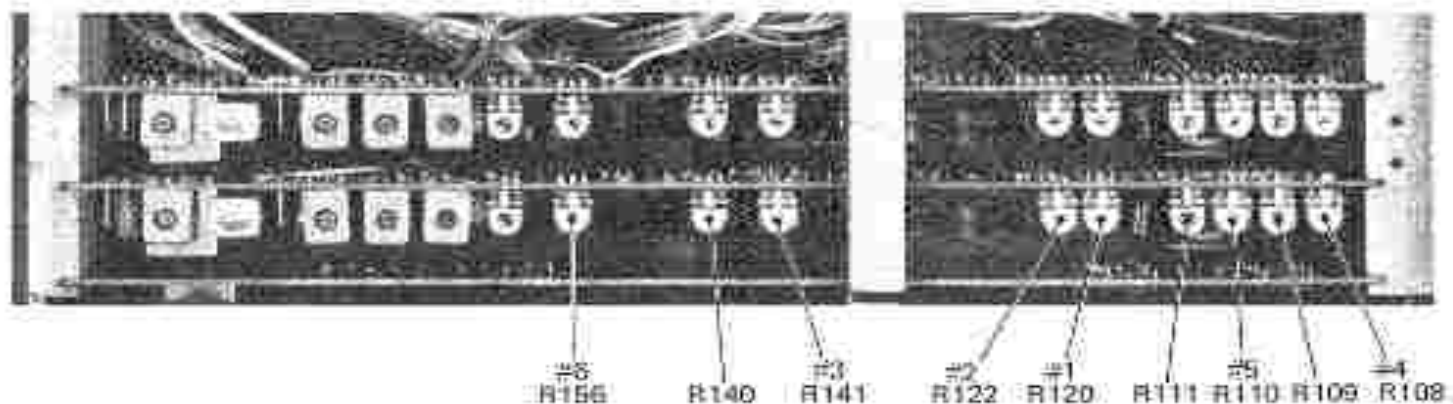

By adjusting all of the preceding trimmers, you have established two things: an operating playback level or "zero", and a playback frequency response reference. You know that both heads on the 32 are reproducing the test tape in an identical manner, at 15 ips.

You now repeat the frequency adjustments for both heads at 7-1/2 ips. Change test tapes and use trim pot #4 R109, 10k ohms and adjust the high frequency playback response for "REPRO". The reading on the meter should be "0 VU". If you are still using the VTVM, the reading will be -10 dB. The test frequency is 18 kHz.

Repeat the adjustment for "SYNC" trim pot #5 R111, 20k ohms at 18 kHz. The reproduce response section is now complete for both speeds.

### 3) Input Calibration:

It stands to reason that you should monitor the level of the signals which are going to be recorded, before actually making the recording itself. This monitoring signal can be fed to the VU meters and, at the same time to the output terminals. The required procedures are:

Connect the reference level, or signal generator to channel L input on the 32.

The correct level is -10 dB (0.3 V).

The frequency to use is 400 Hz. Rotate INPUT knob and OUTPUT knob on the front panel to the "7" position. It's a good idea to mark it. Check the OUTPUT SELECT. Make sure you have the button marked INPUT depressed. If you get a reading, use trim pot #6, R156, 2k ohms, INPUT LEVEL, and adjust the meter to read 0 VU. If you have a VTVM, connect it to the output terminals, and adjust the input level by using trim pot #6, R156, 2k ohms to obtain the correct -10 dB (0.3 V) level. Plugging and unplugging test equipment can be tedious. You can save some time by doing a reference check on your mixer. If you know that your console meter reads 0 VU accurately (check it with the VTVM), you can assign the reference oscillator signals to the 32 through the mixer connections to the inputs. Assign, read, adjust; next track, assign, read, adjust . . . no need to pull plugs.

### Record Calibration

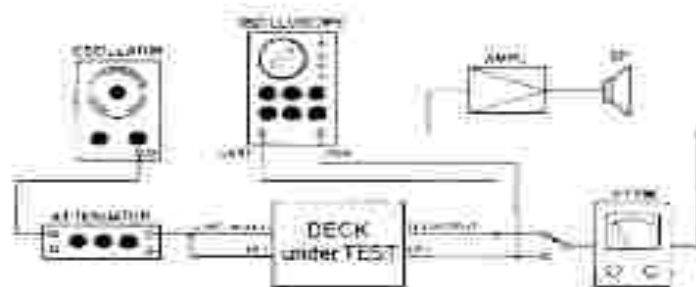

Test Connection for Recording Check

Now you can use the REPRO head as a test instrument to check and adjust the record circuits. Almost all of the following steps involve recording a tone on a tape and reading the reproduce output of the recorder. **YOU WON'T ALTER THE REPRODUCE CONTROLS.** They are all set. You will make all necessary adjustments by trimming the record electronics.

This way, you can be sure that the recordings you make, no matter what brand of tape you use (the brand of tape becomes part of the test tones on it), will reproduce properly on any 32.

The alignment tape can be put away. Before storing, the tape should be played all the way from front to back (not fast wound), and stored tails out, so it will last longer. Even if you decide not to attempt any major maintenance yourself, we strongly suggest that you purchase an alignment tape. An occasional playing will tell you when you need to call the "doctor". It's good insurance to know the truth.

The record adjustments begin with the INPUT LEVEL trim of the 32. The INPUT LEVEL controls the meter reading of the signal as it arrives at the electronics (before it is recorded). You must be sure you are sending the right amount of signal in before you can adjust record levels and equalization controls.

#### 4) About the Bias

At this point in the adjustment procedure we'll stop for a time and talk about a major section of the recorder electronics: the oscillator and its related circuitry. The oscillator produces a very high frequency signal that does two big jobs in the 32. It supplies the 150 kHz (one hundred fifty thousand cycles per second) frequency to the bias amplifier in the 32. There is a bias amplifier on every card, one for both tracks. The bias amplifier provides power for the erase head and bias signal for the record head. Erasure is easy to explain, so we'll tackle that subject first. A lot of power is used to remove all signal from the tape just prior to its being recorded. The erase head has a rather large gap and completely cleans off any magnetic field on the tape by brute force. No new signal is recorded by this head. The gap is much too large to be effective as a recording device. From the same amplifier, current is added to the record head circuit lead. This high frequency signal overcomes magnetic inertia in tape, and gets everything moving. If there were no "starter current" to help the record signal, we would see this kind of trouble on a scope.



The beginning and ending points of the wave would be distorted by the reluctance of the iron bits to change their magnetic state from one polarity to the other. Crossing that zero line

takes extra energy. The bias signal provides it. We put in this:



Where did the 150 kHz go? It disappears from the output because the head gap is too large to play it back. The individual changes of magnetic energy on the tape are smaller than the gap size so a plus and minus wave are both within the gap at the same time. They cancel out. Marvelous! On with the problem of alignment. Well, maybe not so marvelous. Because of the fact that there is one amplifier doing 2 separate jobs. The adjustments we make on one circuit will affect the other. In fact, the erase current fixed, but there are 2 interfacing circuits and life can get pretty tricky right here. The 2 adjustables are (in sequence):

1. The bias current (for the record head) trim capacitor C134 100P max. BIAS LEVEL.
2. The bias traps. Since there is a lot of power involved here, you have 2 problems.

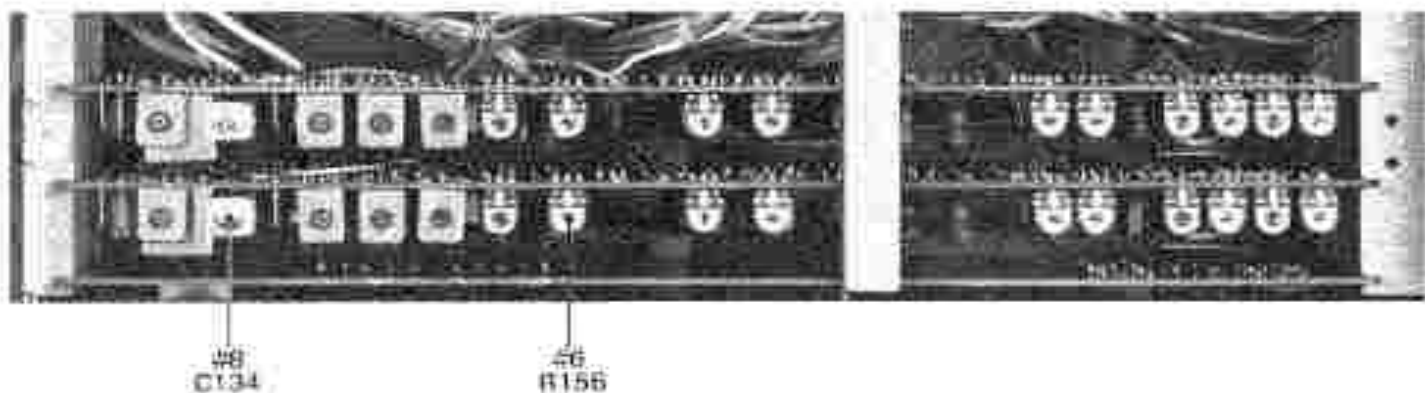
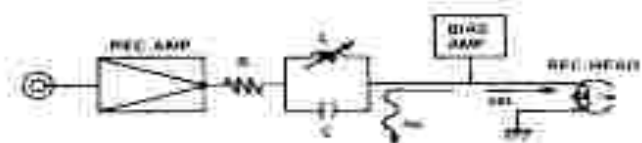

We've give you the bad news (they interact). Now we'll give you the good news. Unless you adjust the erase current or the bias current by a very large amount, you won't need to check these circuits more than once every six months or so. The traps seldom need adjustment unless something is wrong with the master oscillator. The "traps" are expected to tune out the 150 kHz frequency that the bias oscillator is producing, and the range of adjustment that they have is not very good at filtering a much different frequency. If the master bias oscillator drifts, it must be re-adjusted to produce 150 kHz. Since this bias oscillator master circuit adjustment requires something expensive (very) called a frequency counter, it's wise to assume it's a dealer problem. Cart it in for this kind of service. There are also bias traps in the reproduce circuit to keep any stray leaks out of them as well, but they are not as touchy as the record-related circuit traps, and won't affect the load on the bias amplifier. They are tricky to adjust, but very stable. In sequence, you adjust them (if necessary) at the very end of the entire alignment procedure so we'll mention them again.

### 5) Bias Level Adjust:

This adjustment is made while you are recording a tone on the type of tape you'll be using for the session. It will be different for each brand of tape. Set up the signal generator (oscillator). The frequency is 7 kHz, -10 dB (0.3 V). Depress INPUT SELECT to LINE, and set both FUNCTION buttons to ON, then set INPUT and OUTPUT knobs to the "7" position. The level should be 0 VU on the meters of the 32 on INPUT. Start the machine at the tape speed 7-1/2 ips, record the signal, and switch to REPRO on the OUTPUT SELECT.

Begin the adjustment by making sure trim capacitor #8 C134 100P max. BIAS LEVEL is in the fully CCW position (off, no bias at all). Now, as you rotate the trim pot #8 CW, the VU meter will rise to some peak reading. CONTINUE THE CLOCKWISE ROTATION SLOWLY until the reading on the meter drops back 4 - 5 dB from the peak.

If, at peak the meter goes off scale, adjust the INPUT level controls to keep the reading on scale. What is important here is not the zero. It is the reduction of the peak by 4 - 5 dB. If you have moved the input level pot on the front panel of the 32 to keep your reading on scale, the next adjustment will correct your input reference.

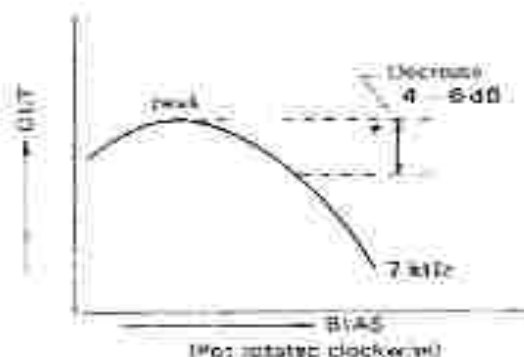
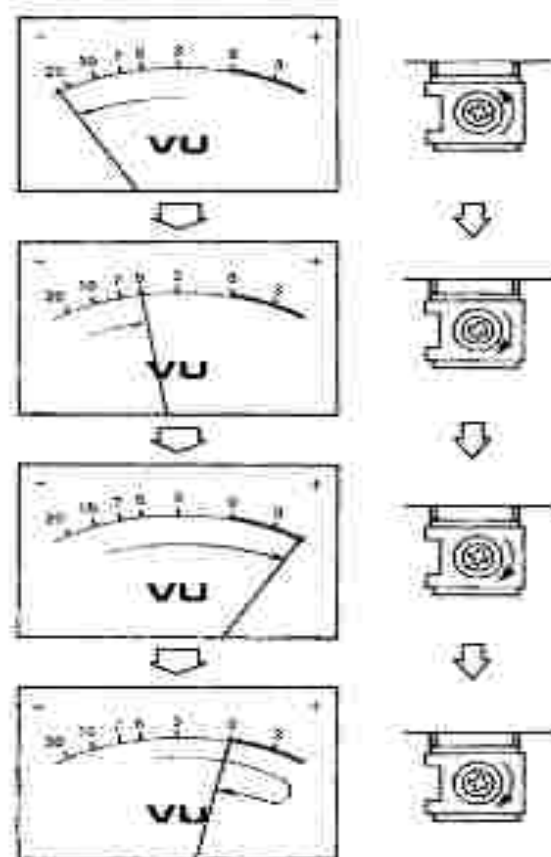

Bias Limits Chart

If there is insufficient CW rotation of #8 to achieve a peak, dealer service of the bias amplifier/oscillator system will be required. Many voltages in the circuit must be adjusted accurately and this type of problem is not considered to be "Daily Maintenance". Bring it in.

When doing bias adjustment, both channels should be recording at once, even though you are adjusting only one at a time.

With the oscillator running at 400 Hz, switch back to INPUT. Set INPUT and OUTPUT knobs on the front panel to the "7" position and adjust trim pot #6, R156 INPUT LEVEL for 0 VU indication on meters.

### 6) Bias Trap Adjust:

Now is the time to do the bias trap in the record circuit: with no input signal, adjust test point TP1 located on the PC Board. Positive side of the VTVM is connected to the test point, negative side to ground. Tune inductor L105 for minimum.

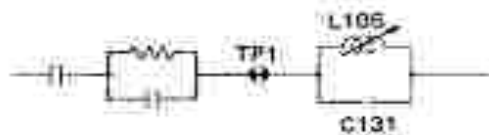

### 7) Record Level Adjust:

We give these adjustments just to be accurate and thorough, and remind you again that they are seldom needed. Unless you have made some really drastic change in your recorder, you should not worry about this adjustment for at least 6 months.

Again, to be thorough, at this point it would be wise to check erase and bias again before proceeding. Once you start a major overhaul it might be necessary to go through these 3 steps — erase, bias and record level adjustments — 3 or 4 times before finally moving on to the "record equalization" and then, once more from erase through to the end. Describing the way is probably giving the manufacturing setup, or head replacement sequence when all values of the record circuit must be re-qualified. If noise is heard, signals

don't erase completely even after adjustment, or there is not enough rotation of the bias trim pot left to get a "drop" in bias, the whole adjustment should be considered, but only under these unusual circumstances.

However, we do recommend that you select a brand of high quality tape and stick to it. Changing bias every day for different tapes will make the recorder cranky and a little harder to adjust. Constant messing with the controls is unwise. It is a much better idea to do as little as possible and let the recorder "settle in" to one kind of tape. We are now ready to adjust the record circuitry. We first check the low frequency input level at 400 Hz to get a reference. The steps are as follows:

1. Adjust oscillator to 400 Hz.
2. Select "LINE" on INPUT SELECT buttons.
3. Set INPUT and OUTPUT knobs on the front panel to the "7" position.
4. Select "INPUT" on OUTPUT SELECT buttons.
5. Set both FUNCTION buttons to ON.
6. Send in 0.316 V, set "0 VU" on the 32 meter.
7. Record the tone at 15 ips.
8. Switch to "REPRO", read the 32 meter.
9. With trim pot #9 R176, 20k ohms (REC LEVEL), adjust to "0 VU".

With only a few adjustments remaining in the complete procedure, let's review all you have done up to this point. Step by step, you have:

1. Cleaned and degaussed the tape path.

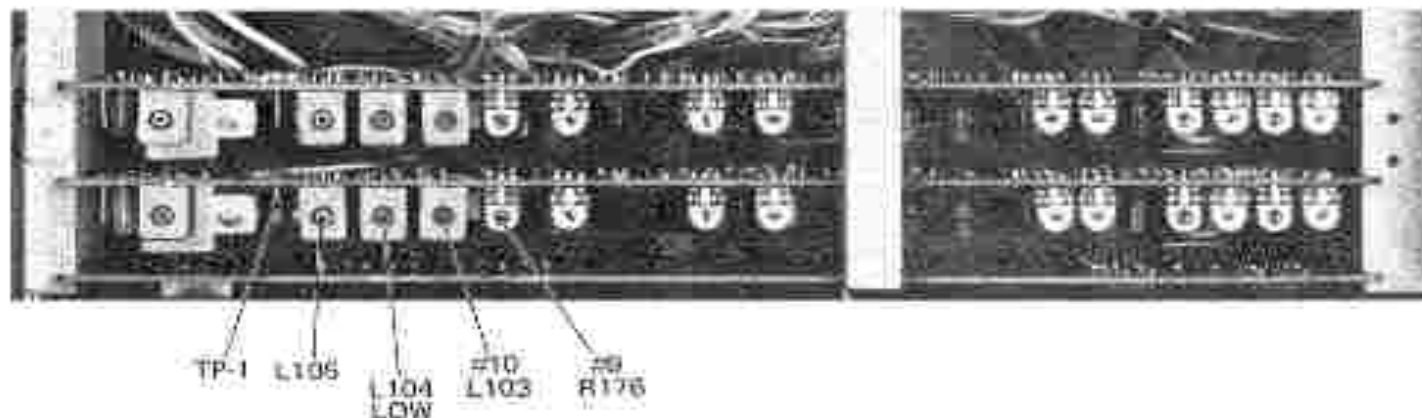

2. Adjusted the head azimuth of both heads to 90° by checking and adjusting progressively higher and higher frequencies.
3. Checked the 32 meters against a precision meter and set 0.316 V output as "0 VU" reproduce.
4. Adjusted reproduce from both playhead positions to be "0 VU" at 400 Hz using the test tapes as an absolute reference of magnetic level.
5. Applied a reference level to the input of the 32 and adjusted the "0 VU" point to be 0.316 V, both in the circuit and on the meter.
6. Set bias level for the tape of choice.
7. If you have the equipment, make sure no bias is going to the record amplifiers.
8. If you have the equipment, set (after bias) the record "0 VU" and read it off reproduce. You now know that the tape you are making has the same level of magnetic flux recorded on it as the reference alignment tape, but only at 400 Hz, the basic adjustment frequency.

### 8) The Peak Adjust Circuit

The choke coil in this circuit only has a very small range, 1 dB at tape speed 15 ips. It is for final high end adjustment. The frequency to send in is 20 kHz, record the tone at "0 VU", switch to REPRO and read the result. Adjust choke coil #10 L103 to read "0 VU" in reproduce.

Both of the record equalization circuits have rather a small range of adjustment. The high frequency adjust is 3 dB, the peak adjust is 1 dB. If you can't seem to get a "good" reading because you run out of adjustment range, check these 3 points.

- The "record adjust" (point # 8 in this review). Re-do, send in "0 VU" at 400 Hz. Record the tone and read reproduce. If it is low, it will be impossible to get 18 kHz or 20 kHz up to "0 VU". Reset and try again. Still no good? Re-check the bias. If the bias current is too high, the high frequency sensitivity is reduced in relation to the 400 Hz point. Check it out.

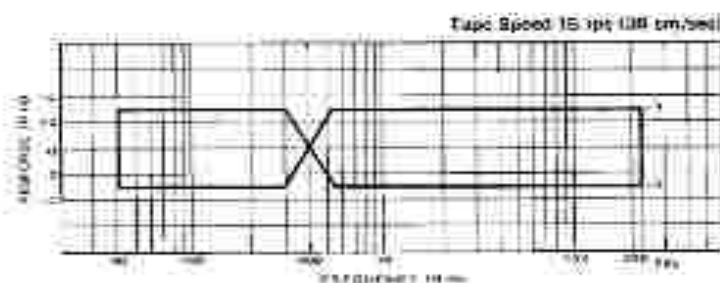

7-1/2 ips tape speed adjustments still remain to be checked and adjusted. The procedures for adjustment are the same as the 15 ips adjustments, but the test tape has to be changed. Send in a 16 kHz frequency and record the tone at "0 VU." If you get a low reading, adjust the #10 choke coil, L104 to read "-3 VU," or higher as necessary.

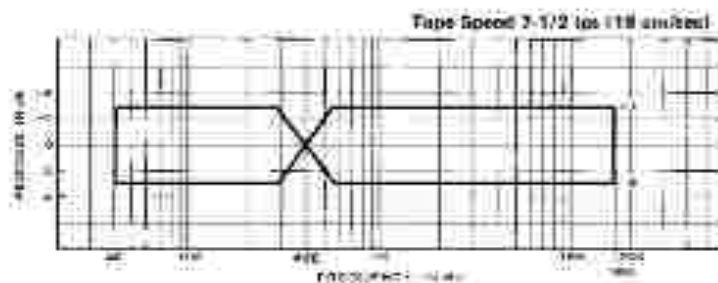

If all this fails to produce a reading that lives within the tolerances for frequency response on this graph, it is time to replace the heads. If more equalization were added to the record circuit to overcome wear, the boost needed would be large enough to make the signal-to-noise ratio specification impossible to achieve.

Let's assume everything is OK so far. You have sent in and read back good numbers for 15 ips, everything in spec at both frequencies. Now, as a check, record everything you have on your tone generator (if it is variable be reasonable, say 9 frequencies) 40 Hz, 100 Hz, 400 Hz, 1 kHz, 4 kHz, 10 kHz, 18 kHz, 20 kHz — compare with the graph above.

Fine tuning the bias against the frequency trim pots will allow you to get a little closer to perfectly flat. It's time consuming but worthwhile. Suit yourself.

With the bottom panel closed, you can now check the signal to noise of the whole system. You use the big test meter and a noise filter. Record with no input signal and read the result. The reading should be -50 dB or better (un-weighted).

That's it. The whole procedure for an electronic overhaul of the 32. Mechanical adjustments such as brake and holdback torque, reel height adjust and wow and flutter measurements must be done first, but they are major service and should not be necessary "out of the box". The transport logic control and switching systems are described in the maintenance section. But digital I.C. theory is very complex and the necessary test equipment for repairs costs more than the recorder. The maintenance section is not written as a guide to the beginner, so be advised, it may not help your understanding of the 32. It is useful only to the experienced maintenance technician.

## DAILY SETUP

It's obvious that this entire procedure is not something that can be completed quickly. You don't begin a "major" ten minutes before the musicians arrive. It is not likely to be necessary every day, but what is reasonable? Most good engineers make several quick tests. If nothing is amiss, they start setting up the rest of the session with confidence. If there is a problem, they go further. Here is what they do.

1. Clean and degauss. Obvious first step.
2. After the recorder has been on for 10 minutes and is nicely warmed up, they check the reproduce response with the test tape. A little trim? OK, no problem.
3. They then set up the signal generator and record several frequencies, say 100 Hz, 4k, 10k. Looks good? Then we can begin.
4. A very fussy engineer will take a look at the bias adjust to make sure everything is OK there as well, before he looks at the record EQ.

These several quick checks will usually uncover any serious trouble, and the idea is to work backwards up the chain of adjustments if anything shows an error. "Reproduce" is the first step in a major overhaul, and Record EQ is the last. If everything works OK, you can assume all is well. If you get something funny as a reading, you will have to track it down, but these tests will usually give you some idea of where the problem lies. Work backwards through the recorder (that's forward through the adjustments, by the way, they run from back to front in the procedure, don't get confused) until you uncover the problem. You always clean and degauss, and you should always check the reproduce response with the test tape. Again, reproduce, bias, record check, no problems, OK, go, and good luck with your tapes.

Speaking of tape, the 32 has been designed to use 1.5 mil tape, the use of 1 mil tape is not recommended, we strongly suggest that you buy good quality tape and stick to one kind. White box tape is cheap for a reason. It doesn't perform as well as the "good stuff", and will be hard to tune up to, and may even damage your recorder. Excessive shedding of oxide, uneven slitting and other defects too numerous to mention will make all your efforts go for very little. Tape is important, use the best.



## GENERAL ADVICE ON MAINTENANCE

Don't attempt to adjust a stone cold machine. Turn it on and let it warm up for 30 minutes.

Don't adjust the "traps" with a metal screw driver or tool. The metal tip will affect the value of the part and will give false readings. Use a plastic T.V. adjustment tool, or cut a strip of rigid plastic to size. (Credit cards will work, if you have an old one you don't need.)

Suspect any large change in adjustment that happens all at once.

Stop and think; if you turn a pot and get no change in reading, have you adjusted the wrong control?

Always turn the machine "off" when installing the extender card.

Remove the alignment tape from the heads when switching power "on" or "off." A switching transient on a badly adjusted recorder can "print" on the tape.

Tape and electronic "bias" should be smooth sounding. If, when recording, you detect popping, or sputtering noises, degauss the heads. If this doesn't change the sound, plan on a record bias trap adjustment.

If the oscilloscope picture is not stable when using the alignment tape (the trace opens and shuts like a mouth) suspect the holdback torque adjustment. When recording and playing test tones, suspect the tape slitting as well as the motor adjusts. If the reference tape doesn't do this, but the recording tape does, it's definitely not the recorder. It is the tape that is at fault.

At the end of a session, take the time to slow wind (play) the roll off the machine and store it "tails out." This is the best way.

Don't plan on recording over a splice. Any steady tone such as singing, or violins that you attempt to print over a cut in the tape may show a dropout, or momentary interruption. Even the best splice in the world is thicker than normal. The splicing tape adds quite a lot, and makes the tape "bump" when it goes by the head. This is especially important if you are using DBX. The dropout will be made much more noticeable by the action of the DBX.

It is a good idea to pad your master tapes by winding some blank tape on both ends, and adding leader tape.

Put a test tone (1 kHz) on each tape for reference level checks. Then it's easier to set up machines and mixers when recording sessions occur on different dates or different machines.

Keep a TRACK SHEET. Write down what happened during the session and what went on to the tape. You might list such things as mic placement; complete/incomplete takes; brand of tape used; speeds; noise reduction; comments (for example: a producer might have liked a particular bass part more than others, so you can save it and use it during overdubbing and mix-down).

Have the tools of the trade handy — leader tape, razor blades, splicing tape, masking tape, grease pencils, etc.

There's another old saying around studio circles: If it's not labeled, use it. So it's a very good idea to label all tape boxes and reels. And pack a track sheet in every box.

When you're not working on a tape, it's safest to put it in its box; don't leave it on the machine where an accident could wipe out weeks of work.

## SERVICE CHART

ADJUST STEP	WHAT IS IT CALLED	SIGNAL SOURCE AND AMOUNT	WHAT TEST GEAR TO USE	WHAT IS THE REORDER DOING?	POINT TO ADJUST	WHAT READING TO ADJUST FOR
1	Reproduce head Alignment	TEAC YTT-1003 Playback Alignment Test Tape (7-1/2 ips)	VTVM and Oscilloscope with vertical and horizontal inputs connected to OUTPUT channels L and R.	Playback at 7-1/2 ips speed. OUTPUT SELECT at REPRO. OUTPUT knob at position "7".	Repro head #3 azimuth adjusting screw.	Adjust for maximum output and for output of tracks L and R less than 90° out of phase (at 12.5 kHz)
2	Sync head Alignment	Same as above	Same as above	Playback at 7-1/2 ips speed. OUTPUT SELECT at SYNC. OUTPUT knob at position "7".	Record head #2 azimuth adjusting screw	Same as above (at 10 kHz)
3	Reproduce Level (head #3)	TEAC YTT-1004 Playback Alignment Test Tape (15 ips) Play 400 Hz reference level signal.	VTVM connected to OUTPUT terminal	Playback at 15 ips speed. OUTPUT SELECT at REPRO. OUTPUT knob at position "7".	Trim pot #1 R130 (REPRO CAL)	-10 dB (0.3 V) on VTVM
4	Sync Reproduce Level (head #2)	TEAC YTT-1004 Playback Alignment Test Tape Play 400 Hz reference level signal.	Same as above	Playback tape at 15 ips. OUTPUT SELECT at SYNC. OUTPUT knob at position "7".	Trim pot #2 R122 (SYNC CAL)	-10 dB (0.3 V) on VTVM
5	REPRO Meter Adjustment	Same as above	VU Meter	Same as above	Trim pot #3 R141 (METER CAL)	Adjust to read 0 VU on VU meter
<p>REPEAT STEP MARKED WITH AN ASTERISK FOR EACH CHANNEL. THE ADJUSTMENT NUMBERS ARE THE SAME BUT THE CIRCUIT BOARD LOCATION, INPUT/OUTPUT TERMINAL NUMBERS, VU METERS, ETC., WILL BE DIFFERENT DEPENDING ON THE CHANNEL.</p>						
6*	REPRO EQ at 15 ips speed (head #3)	Test Tape Play 16 kHz signal on the tape.	VTVM connected to OUTPUT terminal or VU meter	Playback at 15 ips speed. OUTPUT SELECT at REPRO. OUTPUT knob at position "7".	Trim pot #4 R108 (REPRO EQ)	Adjust to read 0 VU on VU meter or -10 dB on VTVM
7*	Sync Reproduce EQ at 15 ips speed (head #2)	Same as above	Same as above	Playback at 15 ips speed. OUTPUT SELECT at SYNC. OUTPUT knob at position "7".	Trim pot #6 R110 (SYNC EQ)	Same as above
8*	REPRO EQ at 7-1/2 ips speed (head #3)	Test Tape Play 10 kHz signal on the tape.	Same as above	Playback at 7-1/2 ips. OUTPUT SELECT at REPRO.	Trim pot #4 R109 (REPRO EQ)	Same as above
9*	Sync Reproduce EQ at 7-1/2 ips speed (head #2)	Same as above	Same as above	Playback at 7-1/2 ips. OUTPUT SELECT at SYNC. OUTPUT knob at position "7".	Trim pot #5 R111 (SYNC EQ)	Same as above
10*	Input Level	400 Hz signal at -10 dB from oscilloscope connected to LINE IN terminal.	Same as above	Stop mode INPUT SELECT at LINE. OUTPUT SELECT at INPUT. INPUT and OUTPUT knobs at position "7".	Trim pot #8 R156 (INPUT LEVEL)	Same as above
11*	INPUT Meter Adjustment	Same as above	VU meter	Same as above	Trim pot #7 R140 (INPUT METER CAL)	Adjust for 0 VU on VU meter

ADJUST STEP	WHAT IS IT CALLED	SIGNAL SOURCE AND AMOUNT	WHAT TEST GEAR TO USE	WHAT IS THE RECORDER DOING?	POINT TO ADJUST	WHAT READING TO ADJUST FOR
12 *	Bias Level Adjustment Refer to MAINTENANCE section for more precise adjustments.	7 kHz, -10 dB oscillator signal connected to line input jacks.	VTVM connected to OUTPUT jacks.	Record signal on type of tape that will be used for actual recording. FUNCTION at ON. INPUT SELECT at LINE. OUTPUT SELECT at REPRO. INPUT and OUTPUT knobs at position "7". Tape speed at 15 ips.	Trim capacitor #8 C134 (BIAS LEVEL)	While recording adjust trim pot until VU meter indication rises to peak value, then turn pot further clockwise until signal drops off by 4 - 5 VU over-bias.
IF INPUT AND OUTPUT KNOB ARE MOVED, REPEAT STEP 10 CONDITIONS TO RESET.						
13 *	Bias Trap Adjustment	No input signal	VTVM connected to Bias Trap test point TP1. negative lead to ground, positive lead to test point.	Record mode, no input signal.	Trim capacitor L105	Adjust capacitor for minimum output at Bias Trap test point TP1. See page 45 for test point location.
14 *	Record Level	400 Hz signal at -10 dB 30 VU on VU meters connected to input terminals.	VTVM connected to OUTPUT jack or use VU meters.	Record signal on type that will be used for actual recording. INPUT SELECT at LINE. FUNCTION at ON. OUTPUT SELECT at REPRO. INPUT and OUTPUT knobs at position "7". Tape speed at 15 ips.	Trim pot #9 R176 (REC LEVEL)	Set for -10 dB (0.3 V) at OUTPUT jacks or 0 VU on VU meters.
15 *	Record Reproduce Frequency Response at 15 ips speed.	40 Hz to 22 kHz signal at -10 dB connected to input terminals.	Same as above	Same as above	Inductor #10 L103	Check that frequency response matches limits given in Chart. See page 45.
16 *	Record Reproduce Frequency Response at 7-1/2 ips speed	40 Hz to 16 kHz signal at -10 dB connected to input terminals.	Same as above	Record signal on type of tape that will be used for actual recording. INPUT SELECT at LINE. OUTPUT SELECT at REPRO. INPUT and OUTPUT knobs at position "7". Tape speed at 7-1/2 ips.	Inductor #10 L104	Same as above
17 *	Overall Signal-to-Noise Ratio	No input signal	VTVM connected to OUTPUT jacks.	Same as above tape speed at 15 ips or 7-1/2 ips.		Check for -50 dB or better.

# TASCAM

TEAC Professional Division

# 32

<b>TEAC CORPORATION</b>	3-7-3, Nakacho, Musashino-shi, Tokyo 110, Japan Phone: (0422) 52-5811
<b>TEAC AMERICA, INC.</b>	7733 Telegraph Road, Montebello, California 90640 Phone: (310) 726-0333
<b>TEAC CANADA LTD.</b>	540 Brunel Road, Mississauga, Ontario L4Z 2C2, Canada Phone: 905-890-8008
<b>TEAC UK LIMITED</b>	5 Marsh House, Marina Meadow, The Cockey Centre, Watford, Herts. WD1 9TA, U.K. Phone: 0993-31983*
<b>TEAC DELFT/BRAND BRNH</b>	Banstraat 12, 6522S Wierden-Eindhoven, Germany Phone: 0611-71590
<b>TEAC FRANCE S.A.</b>	17, Rue Albert-de Tocqueville, CE 905 32183 Antony Cedex, France Phone: (1) 42.87.01.02
<b>TEAC NEDERLAND BV</b>	Pekindijk 11, 3439 ND Maastricht, Nederland Phone: 05-402-5029
<b>TEAC AUSTRALIA PTY. LTD.</b> A.C.N. 305 409 462	108 Bay Street, Port Melbourne, Victoria 3207, Australia Phone: (03) 648-1738
<b>TEAC ITALIANA S.p.A.</b>	Via C. Cairo 5, 20092 Cinisello Balsamo, Milano, Italy Phone: 02-50018888